

Interactive Catalog
[Click Here](#)

On Index Page click on thumbnails
to go directly to the required products

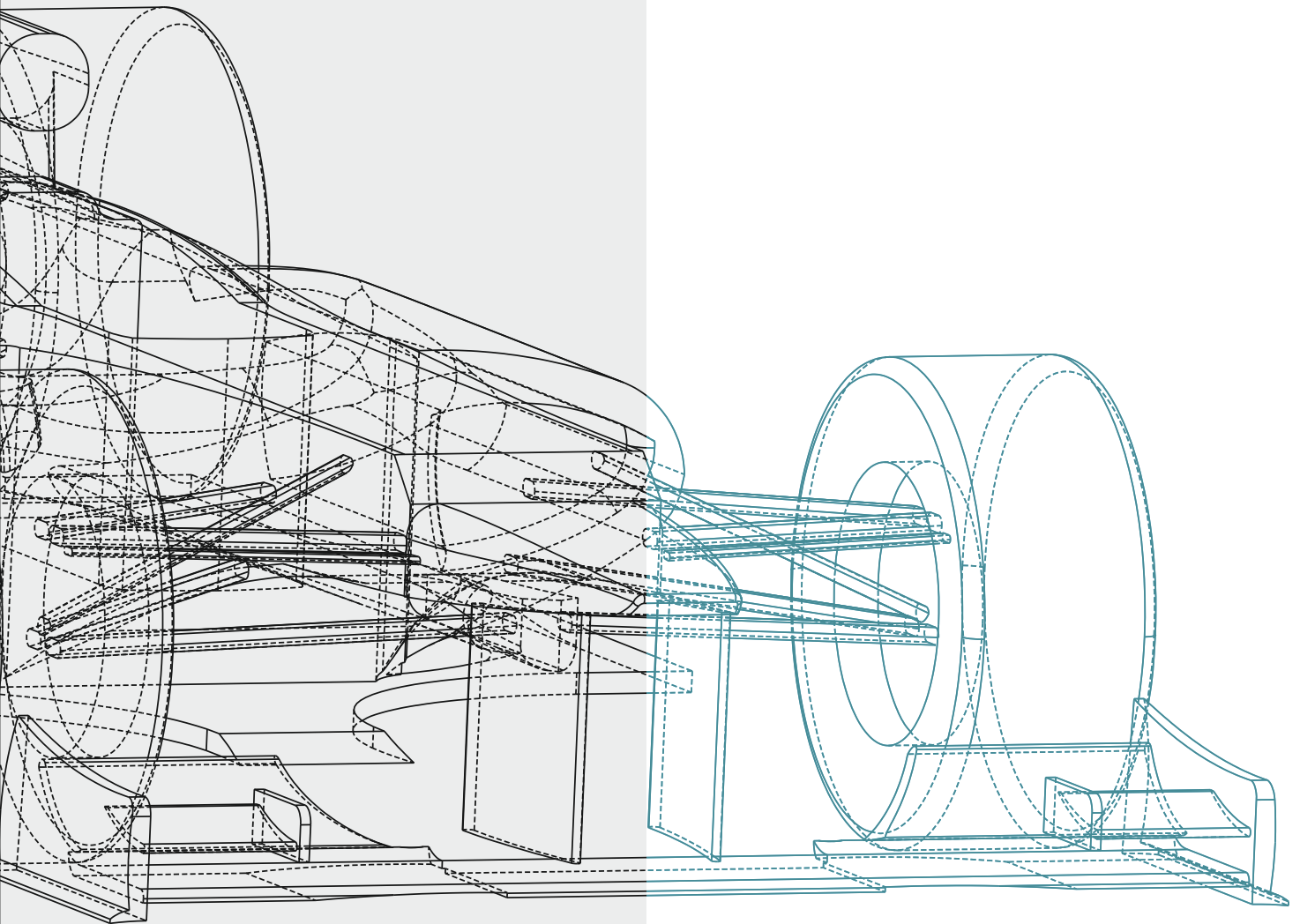

Company Profile

From conceptualization to execution, from drawing to production, there's just one single largest force that drives us. Our customer. He was with us when we first ventured into the uncharted area of toggle clamp manufacturing in India. Four decades later, he still looks up to us with the same trust he began with. Because even as the times changed along with the application areas our products kept pace. Only improving in terms of quality.

Introducing newer and innovative products, continuously improving upon the existing ones and catering to our customers with prompt after sales service; we've grown. We've grown from a small set-up to an established brand name. Today Steel-Smith is the largest manufacturer and exporter of a wide range of toggle clamps and other industrial accessories. In doing so, we owe a lot to our customer; our source of inspiration and unrelenting support.

Cad Database

Steel Smith has placed its entire line of standard clamping products in a CAD library, which customers can use to save valuable drafting time and increase fixture productivity.

All drawings are done in accurate two dimensional orthographic projections or 3D models and are supplied on CDs or by e-mail.

Drawings are available in all of the popular software formats at no charge to the user.

Exports

After capturing majority of the Indian market share, Steel-Smith is now making its presence felt in the global scenario. Constant endeavour in quality enhancements and application areas has led Steel Smith to be a globally competitive toggle clamp manufacturer.

We are proud that we have put India on the world map as far as broad-spectrum toggle clamp manufacturing is concerned. Steel-Smith has exported over one million clamps worldwide.

The latest launch of the international range of clamps has broaden the horizon for the company. Our goal is to see Steel-Smith becoming the first choice for Toggle Clamp application, globally in the next new millennium.











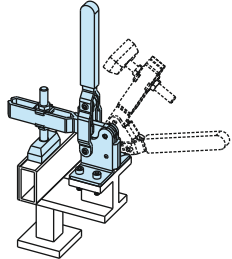
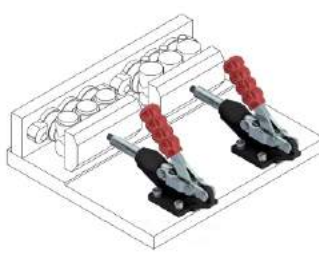







Dealers Network

Steel Smith is now near a city closest to you. With over 20 distributors & stockiest, our Toggle Clamps are just a phone call away from you.

All our distributing centres have application engineers who will assist you in selecting the right clamp for the right application. Please write to us to get our dealers' list.



Index

 <p>Pg. 6</p>	 <p>Pg. 7</p>	 <p>Pg. 8 - 9</p>	 <p>Pg. 10</p>
<p>Introduction</p>	<p>Types of Toggle Action</p>	<p>Applications</p>	<p>VTC Series Heavy Duty Clamps</p>
 <p>Pg. 11</p>	 <p>Pg. 11</p>	 <p>Pg. 12</p>	 <p>Pg. 13</p>
<p>Pull Back Clamps</p>	<p>VTC Light Duty - Flanged Base Holding Capacity 50 -100 Kgs</p>	<p>VTC Medium Duty - Flanged Base Holding Capacity 200 -800 Kgs</p>	<p>VTC Medium Duty - Straight Base Holding Capacity 100 -600 Kgs</p>
 <p>Pg. 14</p>	 <p>Pg. 15</p>	 <p>Pg. 16</p>	 <p>Pg. 17</p>
<p>VTC - Series Medium Duty Clamps - Front Mounting</p>	<p>Cam Action Clamps</p>	<p>H - Series Miniture Clamps</p>	<p>H - Series Medium Duty Clamps</p>
 <p>Pg. 18</p>	 <p>Pg. 19</p>	 <p>Pg. 20</p>	 <p>Pg. 21</p>
<p>Pull Back Action</p>	<p>HTC - Series Forged Base Holding Capacity : 300 Kgs - 4500 Kgs</p>	<p>HTC - LH Series Holding Capacity : 600 Kgs - 800 Kgs</p>	<p>HTC - Series Flat Handle Holding Capacity : 600 Kgs - 800 Kgs</p>
 <p>Pg. 22</p>	 <p>Pg. 23</p>	 <p>Pg. 24</p>	 <p>Pg. 24 - 26</p>
<p>HTC - Series Package Size Holding Capacity : 100 Kgs - 3500 Kgs</p>	<p>HTC - Series Front Mounting Holding Capacity : 50 Kgs - 350 Kgs</p>	<p>PAV - Series Holding Capacity: 100 Kgs - 1,000 Kgs.</p>	<p>PA - Series Holding Capacity: 75 Kgs - 500 Kgs</p>

			
<p>Pg. 27</p>	<p>Pg. 28</p>	<p>Pg. 29 - 36</p>	<p>Pg. 37</p>
<p>PAH - Series Light Duty Holding Capacity: 100 Kgs. - 350 Kgs.</p>	<p>PAH - Series Heavy Duty Holding Capacity: 950 Kgs - 3,000 Kgs.</p>	<p>Latch - Clamps</p>	<p>Squeeze Action Clamps</p>
<p>Pg. 39 - 41</p>	<p>Pg. 42 - 43</p>	<p>Pg. 44 - 59</p>	
			
<p>V. G. Series</p>	<p>F Clamps</p>	<p>Automotive Clamps</p>	
<p>Pg. 60</p>	<p>Pg. 61</p>	<p>Pg. 62</p>	<p>Pg. 63</p>
<p><i>International Range Toggle Clamps</i></p>			
<p>Pg. 64</p>	<p>VTC - 201 Series</p>	<p>VTC - 202 Series</p>	<p>VTC - 207 Series</p>
<p>Pg. 64</p>	<p>Pg. 65</p>	<p>Pg. 66</p>	<p>Pg. 67</p>
			
<p>VTC - 210 Series</p>	<p>VTC - 247 & 267 Series</p>	<p>H - 206, 305, 307 & 309 Series</p>	<p>H - 215 & 225 Series</p>
<p>Pg. 68</p>	<p>Pg. 69</p>	<p>Pg. 70 - 71</p>	<p>Pg. 72 - 73</p>
			
<p>H - 235, 213 & 217 Series</p>	<p>H - 227, 237 & 245 Series</p>	<p>Straight Line Action</p>	<p>Pull Action Clamps</p>

Index

<p>Pg. 74 - 79</p> 	<p>Pg. 80 - 83</p> 	<p>Pg. 84 - 86</p> 	<p>Pg. 87 - 90</p> 
<p>Additional Locking Mechanism</p>	<p>Accessories</p>	<p>Fixture Elements</p>	<p>Clamping Devices</p>
<p>Pg. 91</p> 	<p>Pg. 92 - 93</p> 	<p>Pg. 94 - 96</p> 	<p>Pg. 97</p> 
<p>Introduction of Pneumatic Clamps</p>	<p>Hold Down Action</p>	<p>Hold Down Action - Fixed Cylinder</p>	<p>Hold Down Action - Fixed Cylinder</p>
<p>Pg. 98</p> 	<p>Pg. 99</p> 	<p>Pg. 100 - 101</p> 	<p>Pg. 101 - 102</p> 
<p>Hold Down Action - Right Angle</p>	<p>Straight Line Action</p>	<p>SSC Series</p>	<p>H.V. Series</p>
<p>Pg. 103</p> 	<p>Pg. 104 - 105</p> 	<p>Pg. 106 - 107</p> 	<p>Pg. 108</p> 
<p>Introduction of Swing Clamps</p>	<p>Pneumatic Swing Clamps</p>	<p>Hydraulic Swing Clamps</p>	<p>Link Clamps</p>

All dimensions in this catalogue are specified in "mm"
 For the betterment of the products,
 we reserve the right to change the design and dimensions without prior intimation.

Please visit www.steelsmith.com to download PDF Catalogues, CAD Drawings
 and to view our latest news-letter and product launches.

Write to us to order our CAD CD:



<p>Pg. 110 - 111</p> 	<p>Pg. 112 - 113</p> 	<p>Pg. 114 - 115</p> 	<p>Pg. 116 - 117</p> 
<p>QLSWC Swing Clamps (Mini)</p>	<p>QLSWC Swing Clamps with Cam Handle</p>	<p>QLRE Retractable Clamps with Adjustable Handle</p>	<p>QLRE Retractable Clamps with Cam Handle</p>
<p>Pg. 118 - 119</p> 	<p>Pg. 120 - 121</p> 	<p>Pg. 122 - 123</p> 	<p>Pg. 124 - 125</p> 
<p>QLSWC Swing Clamps with Adjustable Handle</p>	<p>QLSCH Cam Edge Clamps</p>	<p>QLSCL Low-Profile Cam Edge Clamps</p>	<p>BJ130-A Hook-Clamp Assemblies</p>
<p>Pg. 126 - 127</p> 	<p>Pg. 128</p> 	<p>Pg. 129</p> 	<p>Pg. 130</p> 
<p>BJ131 Hook Clamps</p>	<p>CP104 Toe Clamps</p>	<p>CP105 Side Clamps</p>	<p>CP106 Toe Clamps</p>
<p>Pg. 131</p> 	<p>Pg. 132</p> 	<p>Pg. 133 - 136</p> 	<p>Pg. 137 - 138</p> 
<p>CP107 Side Clamps</p>	<p>BJ161 Cam Clamps</p>	<p>CP120 OD Holding Clamps</p>	<p>CP130 ID Holding Clamps</p>



Visit www.imao.biz to view the complete range of more than 10,000 IMAO Products.

View products videos and download CAD Drawings from the website.



Index - KIPP Products

			
<p>Pg. 139</p>	<p>Pg. 140</p>	<p>Pg. 141</p>	<p>Pg. 141</p>
<p>K0309 Spring Plunger with slot and ball, steel</p>	<p>K 0310 Spring Plunger with slot and ball, stainless steel</p>	<p>K0311 Spring Plunger with slot and POM ball</p>	<p>K0312 Spring plungers with slot and stainless steel ball</p>
<p>Pg. 142</p>	<p>Pg. 143 - 144</p>	<p>Pg. 145 - 146</p>	<p>Pg. 147</p>
			
<p>Pg. 148</p>	<p>Pg. 149</p>	<p>Pg. 150</p>	<p>Pg. 151</p>
			
<p>K0657 Spring Plunger with hexagon socket and pressure pin, long version</p>	<p>K0317 Spring Plunger with hexagon socket and pressure pin, steel</p>	<p>K0319 Spring Plunger with hexagon socket and pressure pin, stainless steel</p>	<p>K0321 Spring Plunger with slot and ball, steel, LONG-LOK secured</p>
<p>Pg. 152</p>	<p>Pg. 153</p>	<p>Pg. 154</p>	<p>Pg. 155</p>
			
<p>K0322 Spring Plunger with slot and ball, stainless steel, LONG-LOK secured</p>	<p>K0323 Spring Plunger with slot and pressure pin, steel, LONG-LOK secured</p>	<p>K0324 Spring Plunger with slot & pressure pin, stainless steel LONG-LOK secured</p>	<p>K0325 Spring Plunger with hexagon socket and ball, steel, LONG-LOK secured</p>
<p>Pg. 156</p>	<p>Pg. 157</p>	<p>Pg. 158</p>	<p>Pg. 159 - 160</p>
			
<p>K0326 Spring Plunger with hexagon socket and ball, stainless steel LONG-LOK secured</p>	<p>K0327 Spring Plunger with hexagon socket and pressure pin, steel LONG-LOK secured</p>	<p>K0329 Spring Plunger with hexagon socket and pressure pin, stainless steel LONG-LOK secured</p>	<p>K0368 Lateral Spring Plunger</p>

What is a Toggle Clamp?

Toggle clamp is a simple Mechanism which holds instantly. The Toggle Clamps Consist of a handle to operate, a Clamping Arm to Reach the work piece, linkages for multiplying the applied force, and a base for mounting at the workplace on it's base. The handle is operated which thereby moves the clamping arm to hold the work piece. A required clamping force is achieved and exerted on the work piece. Under this action the Toggle Clamp Holds the work piece firmly and positively.

Toggle Action Force Factors:

Holding Capacity:

The holding capacity mentioned for each clamp refers to the maximum force, which the clamp can withstand after being over-centered without damage to the clamp and without the toggle unlocking due to distortion of the clamp.

The over-center dimension is carefully chosen in relation to the elasticity of the clamp to maximize clamping force while ensuring that the clamp locks closed even under vibration or intermittent loading.

For Hold Down Clamps, holding capacity is measured with the spindle at the farthest end of the clamping arm and will increase as the spindle goes closer to the clamping arm.

Clamping Force:

Clamping Force, the amount of force actually applied to the work piece by closing and locking the clamp, is generally less than the stated holding capacity. Actual clamping force depends on many factors including; spindle position, proper spindle height adjustment, spindle cushioning, work piece material and the clamps mechanical advantage. In most cases, roughly 1/3rd of the stated holding capacity can be applied by hand with medium effort.

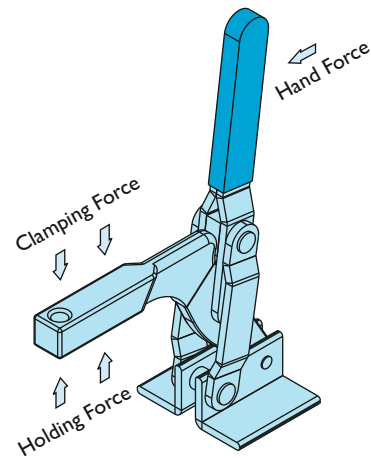
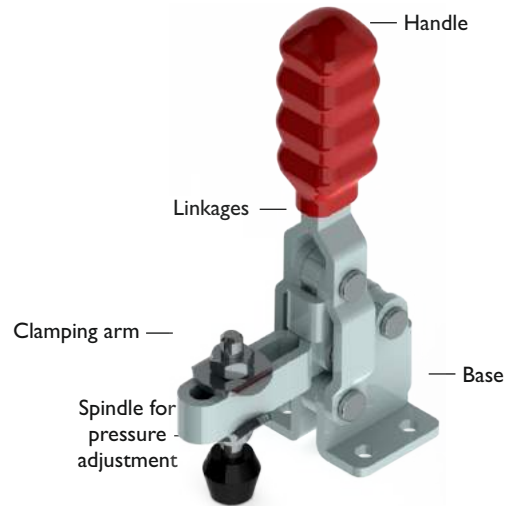

Toggle Principle:

Toggle action clamps operate through a linkage system of levers and pivots. The fixed length levers, connected by pivot pins supply the action and clamping force. Toggle action has an over centre lock point which is a fixed stop and linkage. Once in the over centre position, the clamp cannot move or unlock unless the linkage is moved. All types of toggle clamps have same action, just oriented differently.

The Toggle Mechanism in a clamp has three functions.

- 1) To multiply applied load at the handle into a high clamping force to hold the work piece.
- 2) To create an over - centre lock to prevent the clamp from opening & releasing the work piece until opened by the operator.
- 3) To rapidly open & close the clamp giving a maximum clearance in which to load & unload the work piece.

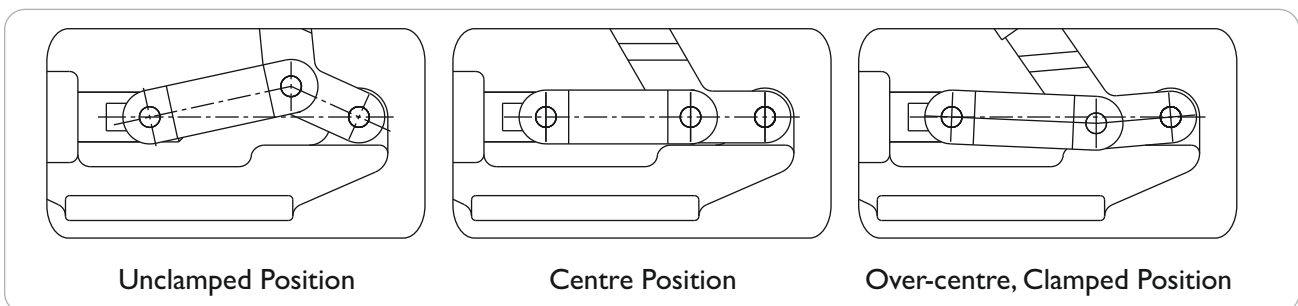

Types of Toggle Clamps

Types Of Toggle Actions

This catalogue contains about 300 different standard toggle clamps & clamping systems. Steel-Smith has developed its range of clamps & clamping equipments for infinite applications, considering the different shapes, sizes, holding capacity, operator's position & strength, frequency of operation etc. Most of the Toggle Clamps belong to one of the following five main actions groups, which are:

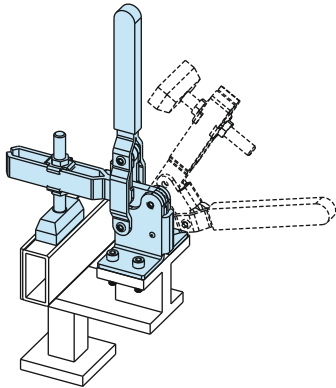

Vertical Hold Down Action : (VTC- Series)

As the name implies clamps of this type hold the work piece with a downward clamping action. These clamps are manufactured with a holding capacity up to 3000 kgs. The clamping exhibits a minimum of 90° opening angle giving full clearance for loading & unloading of workpiece. Clamping arm can be solid bar, U shaped or fixed hole to suit individual requirements.

Horizontal Hold Down Action : (H-Series)

The holding action in these types of Toggle Clamps is same as VTC-Series clamps. The outstanding characteristic is the low height design. Unlike the handle & the clamping bar of the VTC-Series, these of the H-Series clamps move in opposite direction. The holding capacities range upto 1,000 kgs. The clamping arm can be solid bar, U shaped or fixed hole type.

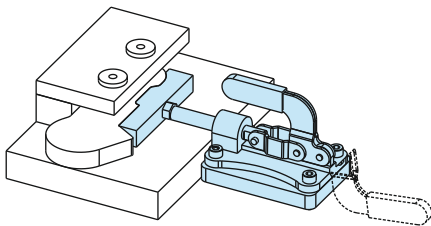
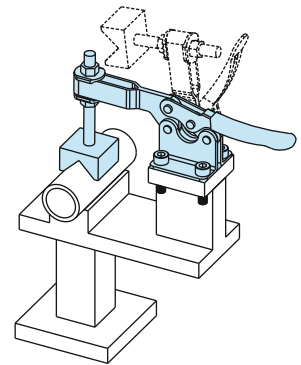

Straight Line Action : (HTC-Series)

The straight line action toggle clamps design uses a straight-line or push/pull, Toggle clamping action. The push / pull handle is easy to operate & moves the plungers of the clamp in and out along its axis. Most of these clamps can be locked in two positions, allowing you to use them as either push or pull clamps. These clamps are manufactured in a variety of models to accommodate a wide range of load ratings. (45 kgs - 4,500 kgs)

Pull Action Clamps : (PAH-Series)

Steel-Smith's Pull Action Clamps are designed for sealing chambers, doors, mould closures or other such applications requiring closure mechanisms. The handle can be moved to place the clamping U - Bolt Bar hook around the opposing latch & pull down to reach the lock position. The threaded "hook" or "U-bolt" type bar offer an adjustment feature. The clamps can withstand pressures from 150 kgs. to 3000 kgs.

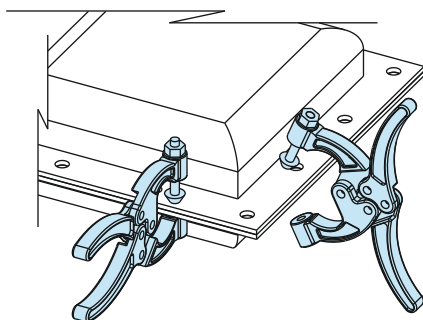
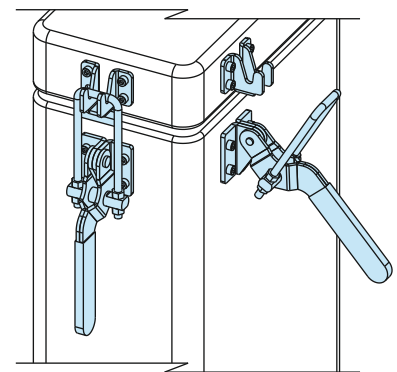

Squeeze Action Clamps: (TP-Series)

Squeeze Action Toggle Clamps hold parts with a pinching or squeezing action between two clamping jaws. The jaws are locked automatically when closing as one or both handle are Squeezed against the central position. The Squeezing action of the clamps makes them well suited for applications where they can replace 'C' clamps. The arms are drop-forged in steel & hence can withstand heat without deformation.



H-45105-UB on Co2 Welding fixture

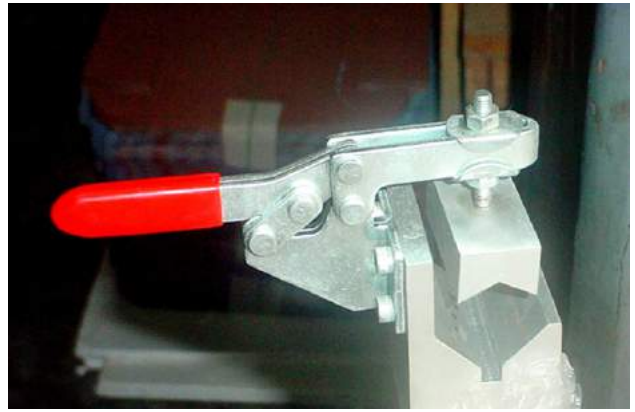

H-4835-UB/FM in gauge checking fixture

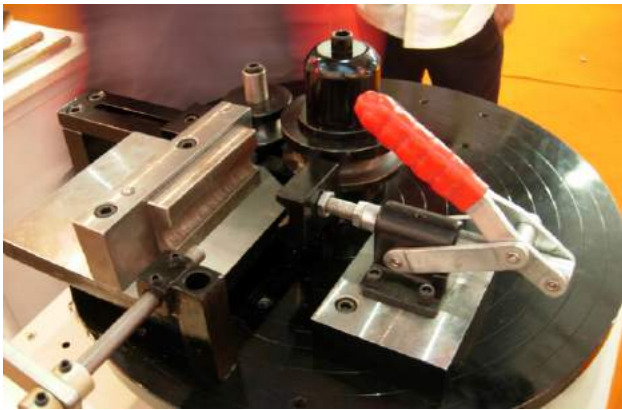

HTC - 5065 used in a pipe bending machine



PAH - 1210 in a Vibro- finishing machine

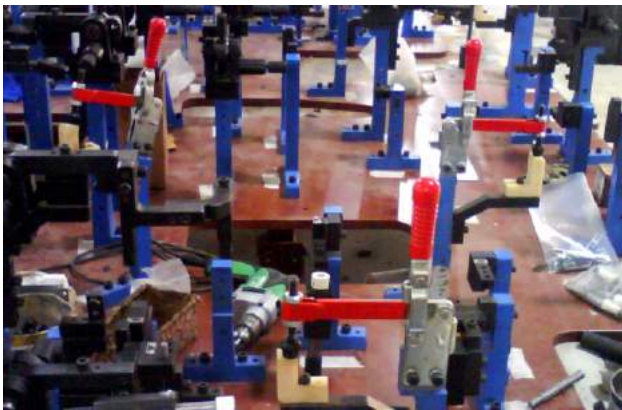

VTC - 4595 - SB/BS on a checking gauge



H - 1330 - UB in a unique paper pad



HV Series Clamp in a BIW fixture



HV Series in a fixture used with standard shims

Application

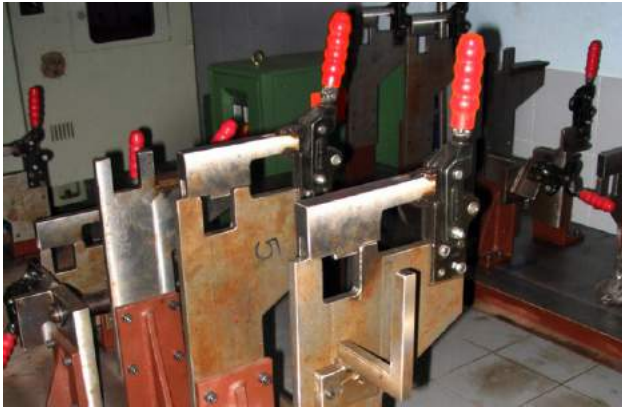

HV Series with modified Arm

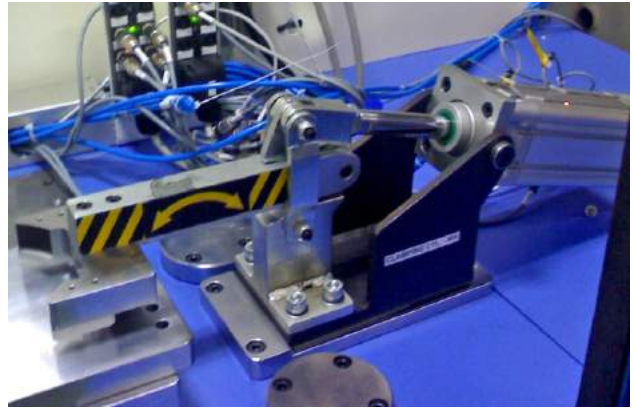

AOT-98125-SB used in a SPM



Numerous HV Series used in a Spot welding fixture



AOT-2530-HTC used to hold cylindrical w/p in tapping process



AOT-3586-SB used in a checking fixture

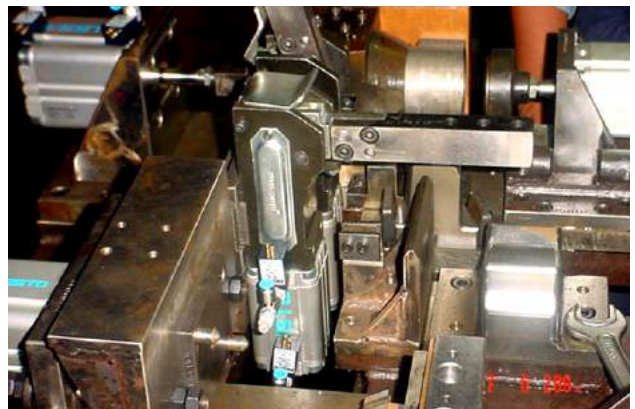

SSC-2550 used in a SPM

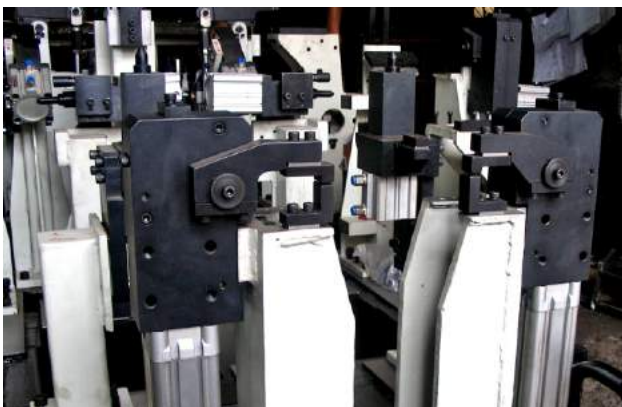

DCTC Series clamps on a Welding Fixture



H - Series Clamps used for Ladder Assembly

VTC Series Heavy Duty Clamps - Angle Base



Model No.VTC-6561 A



Model No.VTC-120132 A

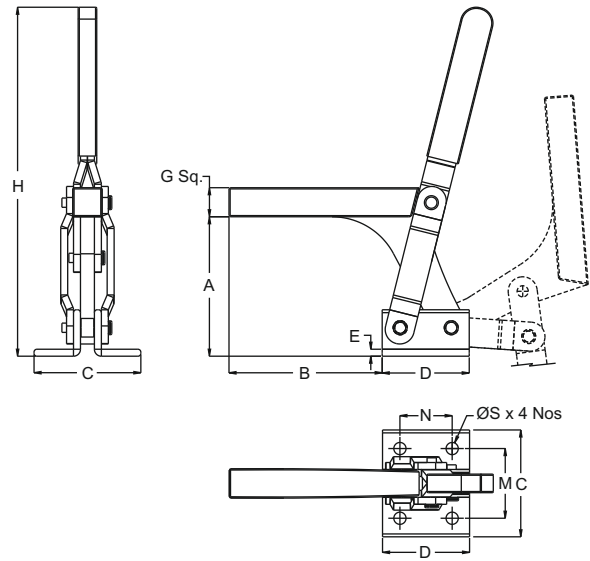

Supplied with suitable spindle

Model No.	A	B	Mounting Base			G	H	Mounting Dimensions			L	Holding Capacity	Wt. in Kgs	Handle Moves	Bar Opens
			C	D	E			M	N	ØS					
VTC-6561 A	65	60	85	45	5.5	20 x 20	179	55	25	6.5	M10 Bolt	500 Kgs	1.000	135°	80°
VTC-120132 A	120	130	92	75	6	25 x 25	300	60	45	10.5	M12 Bolt	1000 Kgs	2.400	140°	85°

Model No:VTC - 9092 - HV - SP

Holding Capacity: 1400 Kgs.
 Weight: 2.600 Kgs.
 Handle Moves : 140°
 Bar Opens : 125°

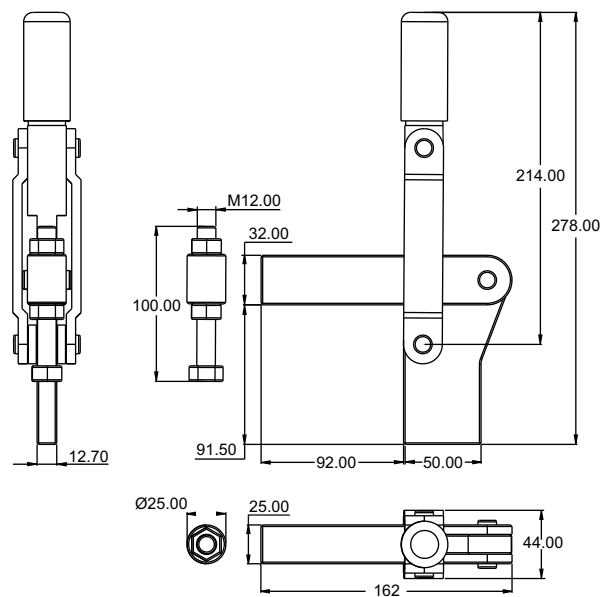
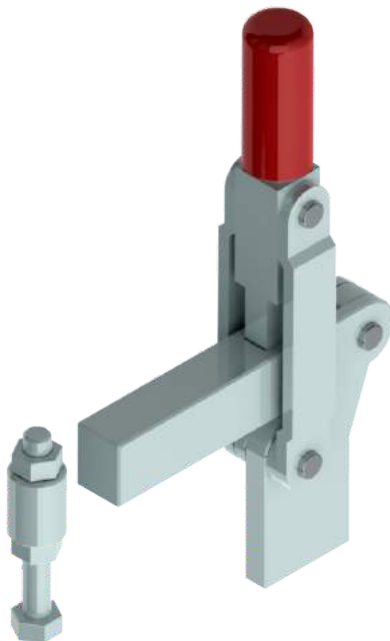

Vertical Hold Down Action

VTC 317 Series

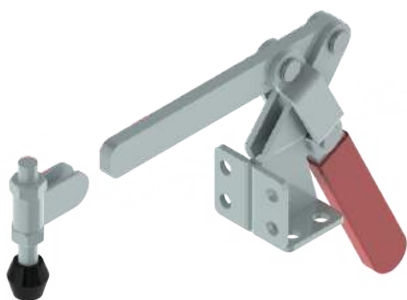

Model No.VTC-317-S

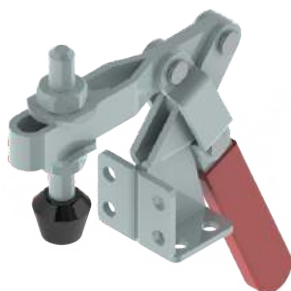

Model No.VTC-317-U

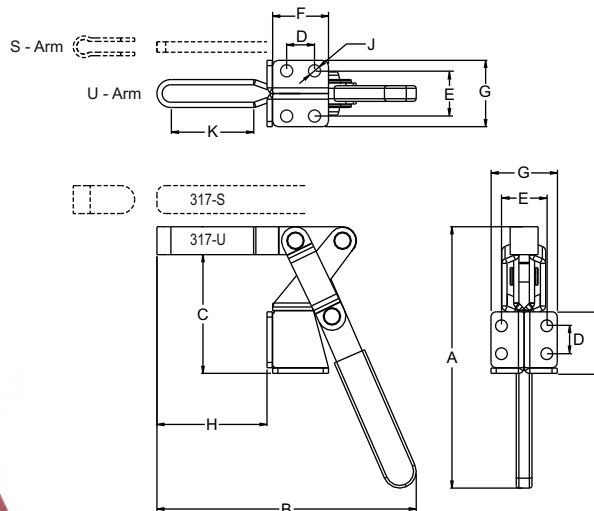

Model No.	A	B	C	D	E	F	G	H	ØJ	K	L	Holding Capacity	Wt. in Kgs	Handle Moves	Bar Open
VTC-317-U	138	150	68	16	25.4	35	38	64	6.7	52	M8 Bolt	170 Kgs	0.360	60°	185°
VTC-317-S	138	167	68	16	25.4	35	38	81	6.7	--	M8 Bolt	170 Kgs	0.350	60°	185°

VTC Series Medium Duty Clamps Flanged Base



Model No.VTC-2535 UB



Model No.VTC-2535 SF



Model No.VTC-2535 SB

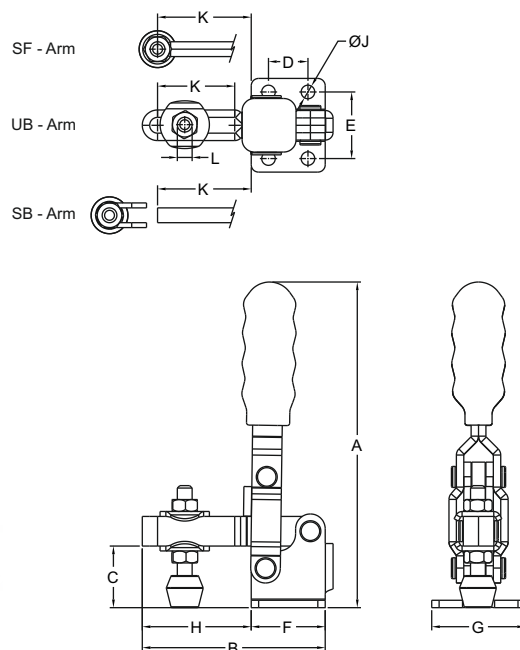

Also Available
in Stainless Steel
VTC-1625-UB-SS
VTC-2535-UB-SS

Model No.	Holding Capacity	Weight Kg	Handle Moves	Bar Opens	Dimensions										
					A	B	C	D	E	F	G	H	J	K	L
VTC - 1625 - UB	50 Kgs	0.090	65°	104°	81	56	16	16	24	25	33	31	4.4	25	M5 Bolt
VTC - 1625 - SF	50 Kgs	0.090	65°	104°	81	56	16	16	24	25	33	32	4.4	25	M5 Bolt
VTC - 2535 - UB	100 Kgs	0.180	65°	104°	125	75	25	16	27	30	38	45	5.5	32	M6 Bolt
VTC - 2535 - SF	100 Kgs	0.180	65°	104°	125	75	25	16	27	30	38	45	5.5	36	M6 Bolt
VTC - 2535 - SB	100 Kgs	0.180	65°	104°	125	73	25	16	27	30	38	43	5.5	43	M6 Bolt

**VTC Series Medium Duty Clamps
Flanged Base**



Model No.VTC-3670 UB

Also Available
in Stainless Steel
VTC-3670-UB-SS



Model No.VTC-3670 SF

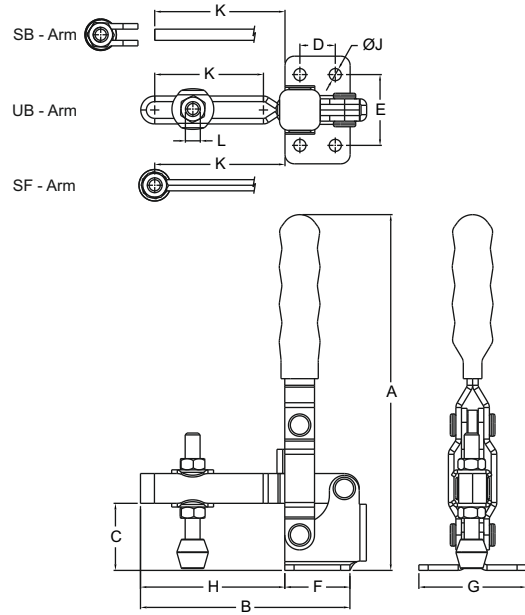

The **SF Series** have a solid hold down bar which has a fixed guide bush at its end for the spindle assembly.
The **SB Series** have a solid bar onto which the bolt retainer can be welded at any desired angle.
The **UB Series** have a 'U' bar arm which enables one or more spindles to be moved into any desired position along the arm.

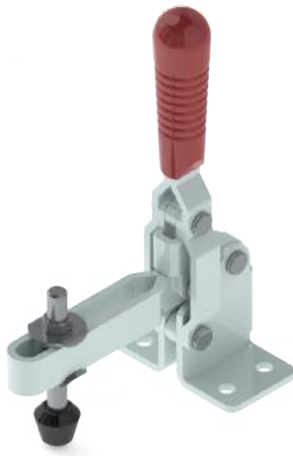

Model No.VTC-4595 UB



Model No.VTC-4595 SF

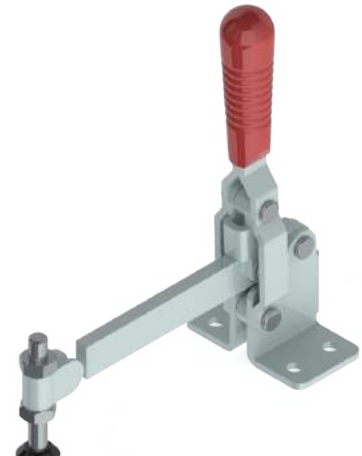

Model No.VTC-4595 SB

Model No.	Holding Capacity	Weight Kg	Handle Moves	Bar Opens	Dimensions										
					A	B	C	D	E	F	G	H	J	K	L
VTC-3670 UB	200 Kgs	0.450	60°	110°	178	115	36	19	38	35	58	80	6.5	61	M8 Bolt
VTC-3670 SF	200 Kgs	0.450	60°	110°	178	115	36	19	38	35	58	80	6.5	72	M8 Bolt
VTC-3670 SB	200 Kgs	0.450	60°	110°	178	102	36	19	38	35	58	67	6.5	67	M8 Bolt
VTC-4595 UB	400 Kgs	0.650	60°	120°	205	150	45	25	55	45	82	105	8.5	80	M10 Bolt
VTC-4595 SF	400 Kgs	0.650	60°	120°	205	151	45	25	55	45	82	106	8.5	95	M10 Bolt
VTC-4595 SB	400 Kgs	0.650	60°	120°	205	141	45	25	55	45	82	96	8.5	96	M10 Bolt
VTC-5040 SF	500 Kgs	0.600	60°	120°	210	99	50	25	45	45	72	54	8.5	44	M10 Bolt
VTC-50125 UB	350 Kgs	0.700	60°	120°	210	181	50	25	45	45	72	136	8.5	114	M12 Bolt
VTC-50125 SF	350 Kgs	0.700	60°	120°	210	182	50	25	45	45	72	137	8.5	125	M12 Bolt
VTC-50125 SB	350 Kgs	0.700	60°	120°	210	175	50	25	45	45	72	130	8.5	130	M12 Bolt
VTC-85150 UB	600 Kgs	2.100	107°	96°	350	238	85	45	60	76	90	162	8.5	108	M16 Bolt
VTC-85150 SF	600 Kgs	2.100	107°	96°	350	241	85	45	60	76	90	165	8.5	150	M16 Bolt
VTC-85150 SB	600 Kgs	2.100	107°	96°	350	218	85	45	60	76	90	142	8.5	142	M16 Bolt
VTC-10088 SF	800 Kgs	1.800	80°	83°	290	182	105	45	60	75	90	106	8.5	91	M12 Bolt

Vertical Hold Down Action

VTC Series Medium Duty Clamps Straight Base

The **SF Series** have a solid hold down bar which has a fixed guide bush at its end for the spindle assembly.

The **SB Series** have a solid bar onto which the bolt retainer can be welded at any desired angle.

The **UB Series** have a 'U' bar arm which enables one or more spindles to be moved into any desired position along the arm.

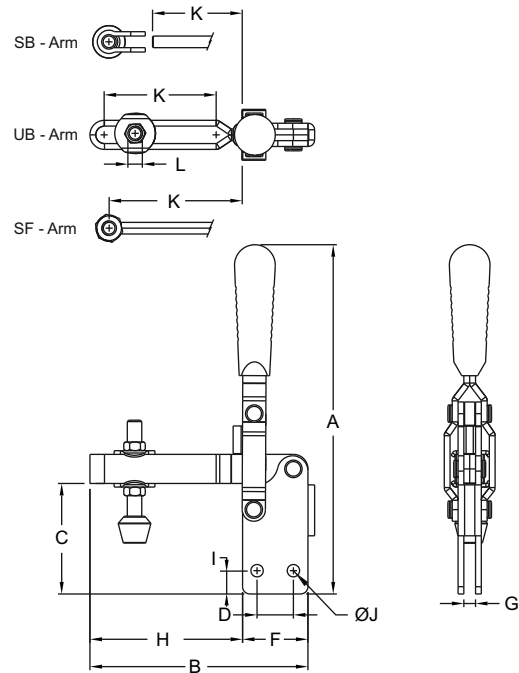

Model No.VTC-4595 UB/BS



Model No.VTC-4595 SF/BS



Model No.VTC-4595 SB/BS

Model No.	Holding Capacity	Weight Kg	Handle Moves	Bar Opens	Dimensions										
					A	B	C	D	F	G	H	I	J	K	L
VTC-2535-UB/BS	100 Kgs	0.180	65°	104°	137	75	36	15	30	6	45	7	5.5	32	M6 Bolt
VTC-2535-SF/BS	100 Kgs	0.180	65°	104°	137	74	36	15	30	6	44	7	5.5	38	M6 Bolt
VTC-2535-SB/BS	100 Kgs	0.180	65°	104°	137	72	36	15	30	6	42	7	5.5	42	M6 Bolt
VTC-8154-SB/BS	200 Kgs	0.300	60°	114°	232	98	79	-	40	6	58	-	-	58	M8 Bolt
VTC-3670 UB/BS	200 Kgs	0.450	60°	120°	198	115	57	19	35	6	80	8	6.5	61	M8 Bolt
VTC-3670 SF/BS	200 Kgs	0.450	60°	120°	198	115	57	19	35	6	80	8	6.5	72	M8 Bolt
VTC-3670 SB/BS	200 Kgs	0.450	60°	120°	198	102	57	19	35	6	67	8	6.5	67	M8 Bolt
VTC-4595 UB/BS	400 Kgs	0.650	60°	120°	232	150	75	25	45	8	105	11	8.5	80	M10 Bolt
VTC-4595 SF/BS	400 Kgs	0.650	60°	120°	232	150	75	25	45	8	105	11	8.5	95	M10 Bolt
VTC-4595 SB/BS	400 Kgs	0.650	60°	120°	232	142	75	25	45	8	97	11	8.5	97	M10 Bolt
VTC-50125 UB/BS	350 Kgs	0.700	60°	120°	232	181	75	25	45	8	136	11	8.5	114	M12 Bolt
VTC-50125 SF/BS	350 Kgs	0.700	60°	120°	232	182	75	25	45	8	137	11	8.5	125	M10 Bolt
VTC-50125 SB/BS	350 Kgs	0.700	60°	120°	232	175	75	25	45	8	130	11	8.5	130	M12 Bolt
VTC-85150 UB/BS	600 Kgs	2.100	107°	96°	375	238	116	45	76	10	162	15	8.5	108	M16 Bolt
VTC-85150 SF/BS	600 Kgs	2.100	107°	96°	375	241	116	45	76	10	165	15	8.5	150	M16 Bolt
VTC-85150 SB/BS	600 Kgs	2.100	107°	96°	375	218	116	45	76	10	142	15	8.5	142	M16 Bolt

Vertical Hold Down Action

Model No:VTC - 6440 - UB/FM

Arm: Adjustable Arm
 Base: Front Mounting
 Holding Capacity: 100 Kgs.
 Weight: 0.200 Kgs.
 Handle Moves: 65°
 Bar Opens: 104°

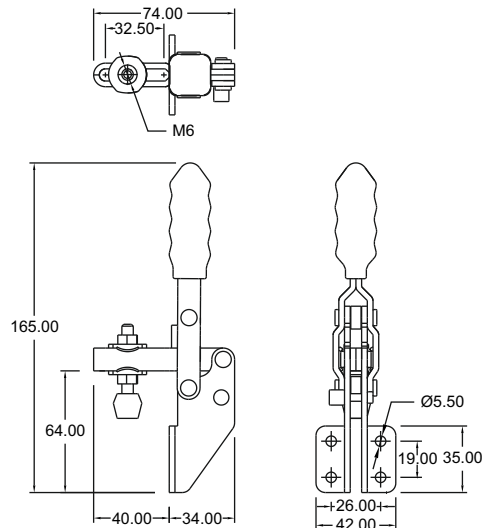

Model No:VTC - 7273 - UB/FM

Arm: Adjustable Arm
 Base: Front Mounting
 Holding Capacity: 200 Kgs.
 Weight: 0.500 Kgs.
 Handle Moves: 60°
 Bar Opens: 120°

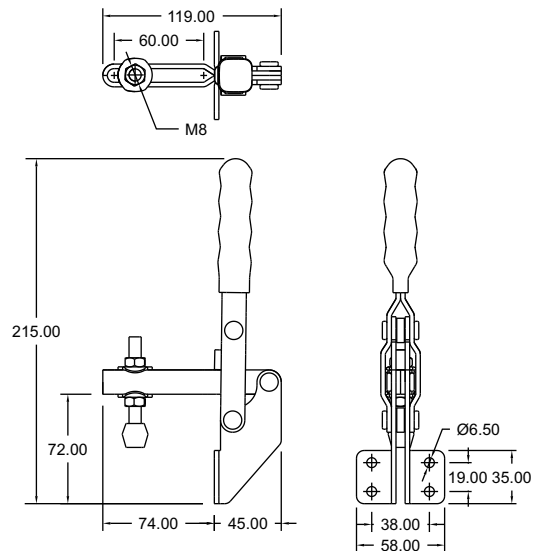

Model No:VTC - 8296 - UB/FM

Arm: Adjustable Arm
 Base: Front Mounting
 Holding Capacity: 500 Kgs.
 Weight: 0.700 Kgs.
 Handle Moves: 60°
 Bar Opens: 120°

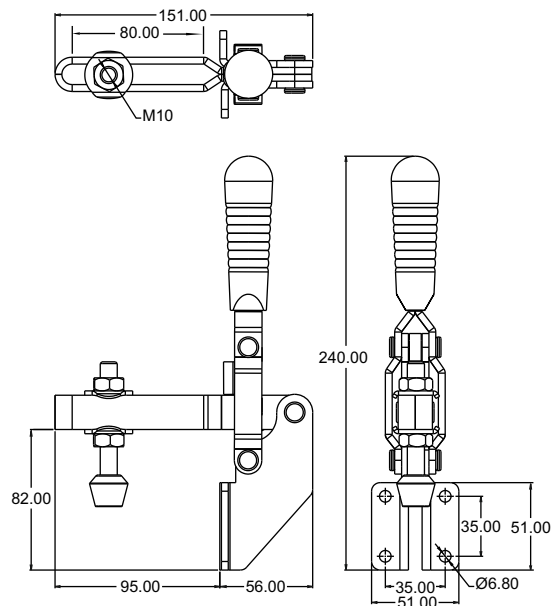

Cam Clamps

Model No:VTC - 516 - SB

Arm: Solid Arm
 Base: Flange Mounting
 Holding Capacity: 300 Kgs.
 Weight: 0.570 Kgs.

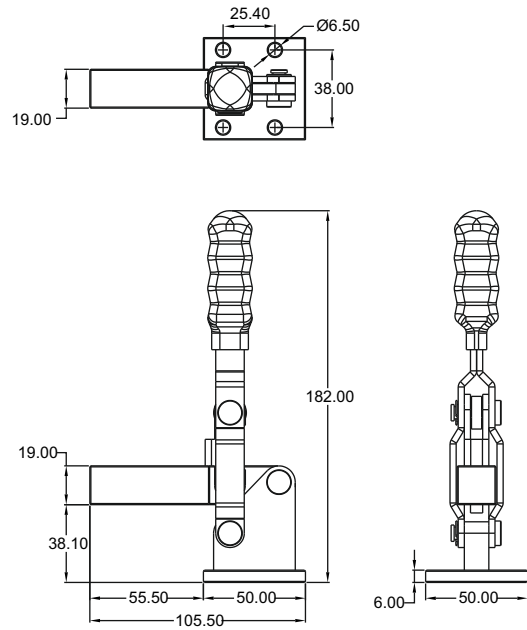

Model No.VTC - 516 - SB

CAM ACTION CLAMPS

Built in clamping range automatically compensates for variations in part thickness. Cam Clamps are similar to Vertical clamps but the clamping force is generated not by a toggle linkage but by the action of a roller on a cam. The Cam Clamps have a high to low limit clamping range that automatically compensates for part thickness variation & therefore eliminates time consuming readjustments. Cam Clamps are available in three sizes offering part variation thickness allowance from 3 mm to 5 mm. These clamps are ideal for fixtures designed for clamping of castings & forgings. The pivots pins, cam & its roller are hardened for higher efficiency of clamps.

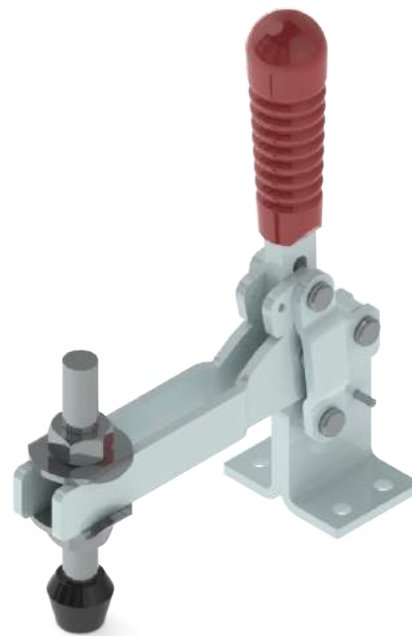
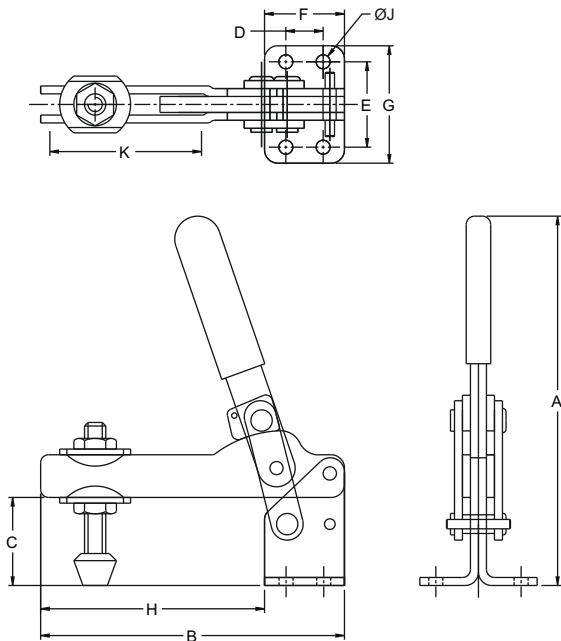

Model No. CAM - 219

Model No.	Holding Capacity	Weight Kg	Handle Moves	Bar Opens	Dimensions										
					A	B	C	D	E	F	G	H	J	K	L
CAM - 219	150 Kgs	0.800	180	115	190.5	150.0	46.0	19.1	38.1	38.1	53.0	112.0	6.5	63.5	M12 Bolt
CAM - 229	450 Kgs	1.100	180	115	230.0	183.0	52.3	22.4	50.8	47.8	70.0	135.0	8.5	69.9	M12 Bolt

Model No: H - 1330 UB

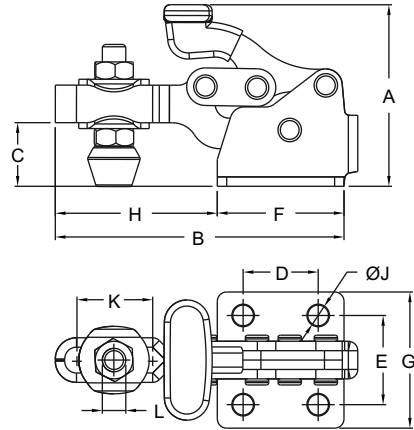

Also Available
in Stainless Steel
H - 1330 - UB - SS

Model No.	Holding Capacity	Weight Kg	Handle Moves	Bar Opens	Dimensions										
					A	B	C	D	E	F	G	H	J	K	L
H - 1330 - UB	50 Kgs	0.070	170°	95°	37	60	13	16	19	26	29	34	4.5	13	M5 Bolt

H - Series Miniature Clamps



Model No. H - 1323 - UB



Model No. H - 1323 - SF

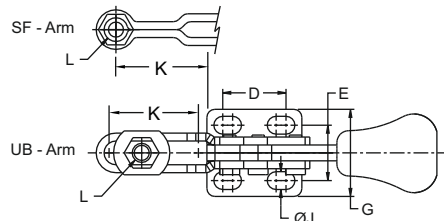
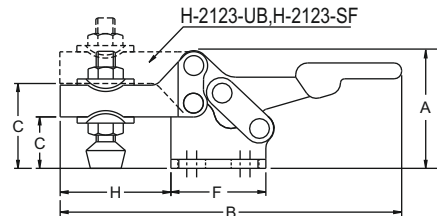

Model No. H - 2123 - UB

Also Available
in Stainless Steel
H - 1323 - UB - SS
H - 2123 - UB - SS

Model No.	Holding Capacity	Weight Kg	Handle Moves	Bar Opens	Dimensions										
					A	B	C	D	E	F	G	H	J	K	L
H - 1323 - UB	50 Kgs	0.040	90°	90°	30	85	14	11-16	14	24	22	28.5	4.5	18	M5 Bolt
H - 1323 - SF	50 Kgs	0.040	90°	90°	30	85	14	11-16	14	24	22	28.5	4.5	24	M5 Bolt
H - 2123 - UB	50 Kgs	0.040	90°	90°	30	85	21	11-16	14	24	22	28.5	4.5	18	M5 Bolt
H - 2123 - SF	50 Kgs	0.040	90°	90°	30	85	21	11-16	14	24	22	28.5	4.5	24	M5 Bolt

Model No: H - 4835 UB/FM

Holding Capacity: 250 Kgs.
Weight: 0.260 Kgs.

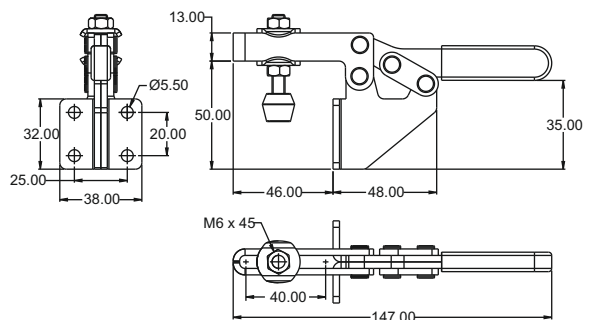

Horizontal Hold Down Action

H - Series Medium Duty Clamps



Model No. H - 2655 SF



Model No. H - 2655 UB



Model No. H - 3665 SF



Model No. H - 3665 UB



Model No. H - 45105 UB

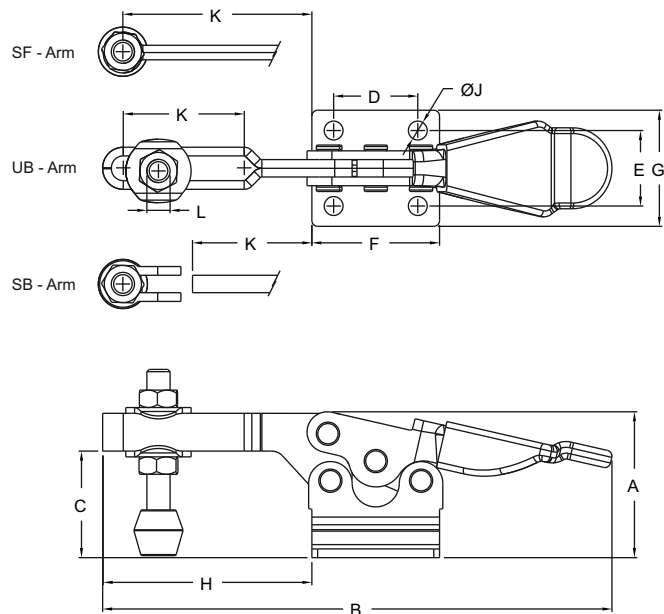

The **SF Series** have a solid hold down bar which has a fixed guide bush its end for the spindle assembly.
 The **SB Series** have a solid bar onto which the bolt retainer can be welded at any desired angle.
 The **UB Series** have a 'U' bar arm which enables one or more spindles to be moved onto any desired position along the arm.

Also Available
in Stainless Steel
H-2655-UB-SS
H-3665-UB-SS

Model No.	Holding Capacity	Weight Kg	Handle Moves	Bar Opens	Dimensions										
					A	B	C	D	E	F	G	H	J	K	L
H-2655 UB	150 Kgs	0.150	70°	90°	39	148	27	24	22	35	33	64	4.5	33	M6 Bolt
H-2655 SF	150 Kgs	0.150	70°	90°	39	148	27	24	22	35	33	64	4.5	58	M6 Bolt
H-3665 UB	250 Kgs	0.260	70°	90°	50	175	36	29	26	44	40	70	6.5	31	M8 Bolt
H-3665 SF	250 Kgs	0.260	70°	90°	50	175	36	29	26	44	40	70	6.5	62	M8 Bolt
H-3665 SB	250 Kgs	0.260	70°	90°	50	175	36	29	26	44	40	55	6.5	55	M8 Bolt
H-45105 UB	350 Kgs	0.560	60°	85°	68	275	45	40	38	57	55	112	8.3	75	M10 Bolt
H-45105 SF	350 Kgs	0.560	60°	85°	68	275	45	40	38	57	55	112	8.3	105	M10 Bolt
H-45105 SB	350 Kgs	0.560	60°	85°	68	275	45	40	38	57	55	95	8.3	95	M10 Bolt
H-57126 UB	500 Kgs	0.880	60°	85°	82	320	60	45	40	65	62	147	8.5	100	M12 Bolt
H-57126 SF	500 Kgs	0.880	60°	85°	82	320	60	45	40	65	62	147	8.5	110	M12 Bolt
H-57126 SB	500 Kgs	0.880	60°	85°	82	320	60	45	40	65	62	150	8.5	120	M12 Bolt

Pull Back Action

Model No: GH – 80379

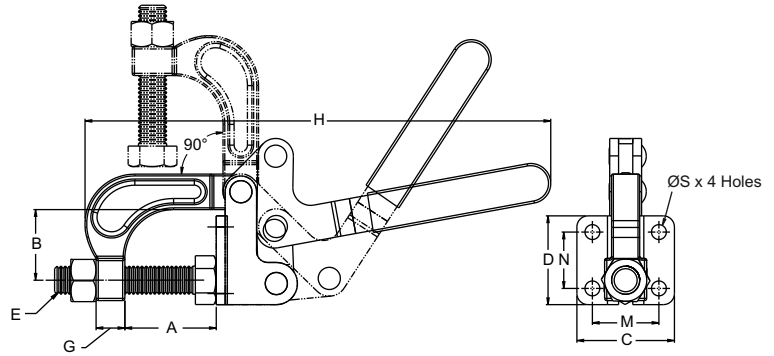

Also Available
in Stainless Steel
GH – 80379 - SS

Model No.	A	B	Mounting Base		E	G	H	M	N	S	Holding Capacity	Wt. in Kgs
			C	D								
GH – 80379	41	32	44	40	M 12	13	210	30	25.4	6.70	400 Kg	0.640

Model No: PB - 345

Holding Capacity: 350 Kgs.
Weight: 3.000 Kgs.

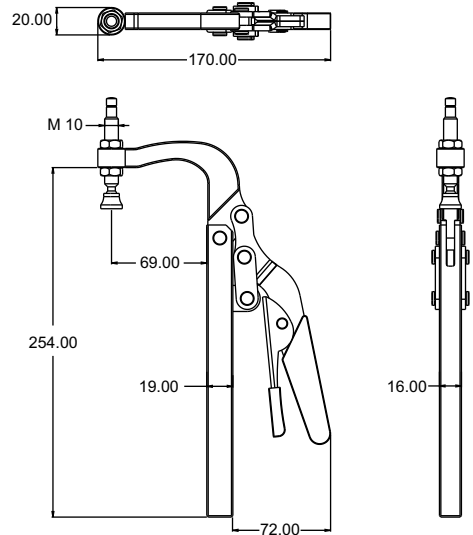

Model No: PB - 4727 - SB

Holding Capacity: 2,000 Kgs.
Weight: 1.100 Kgs.

Also Available
in Stainless Steel
PB - 4727 - SB - SS

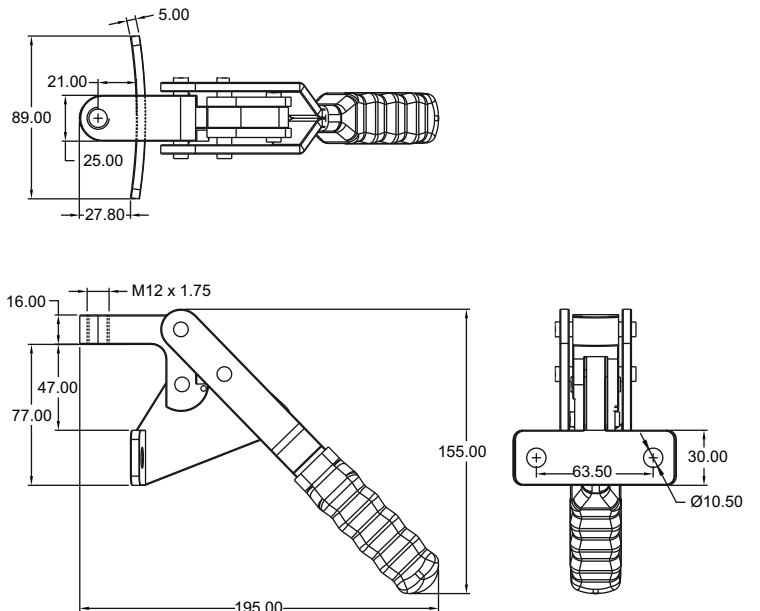
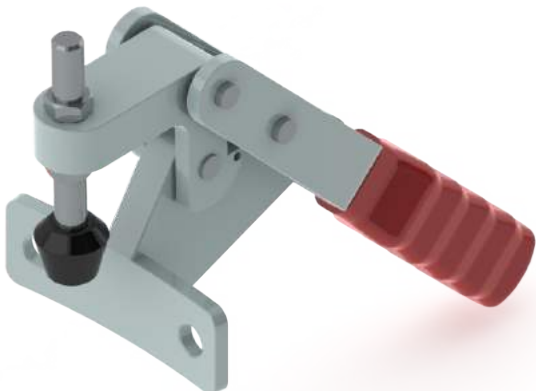

Straight Line Action

Model No: HTC - 1220

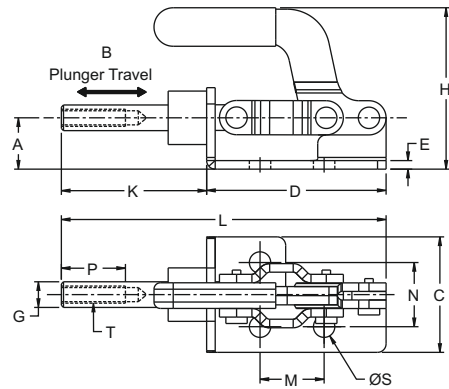

Also Available
in Stainless Steel
HTC-1220-SS

Model No.	A	Plunger Travel B	Mounting Base					ØS	Plunger Dia. G	H	K	L	Hole Depth P	Tapped Hole TØ	Holding Capacity	Wt. in Kgs
			C	D	E	M	N									
HTC-1220	12	20	27	42	2	15	15	5	6	38	34	76	20	M 4 x 0.70	50 Kg	0.050

HTC - Series Clamps Forged Base



Model No. HTC - 3025

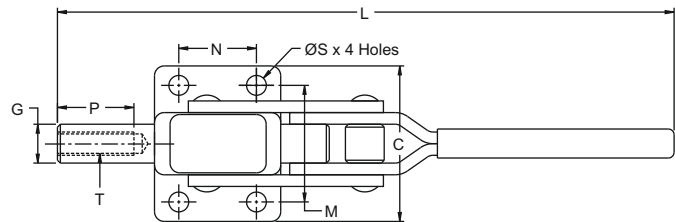

Model No. HTC - 5065

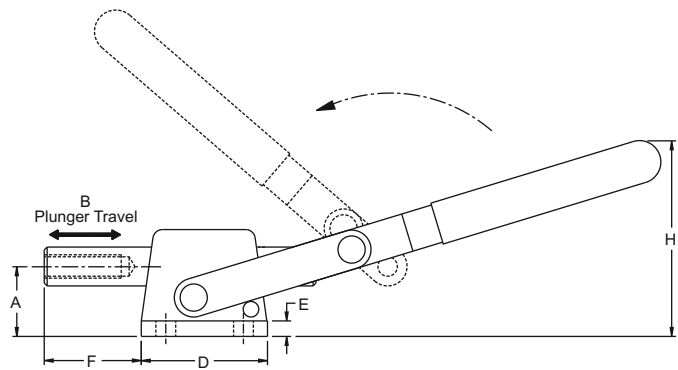

Model No.	A	Plunger Travel B	Mounting Base				Plunger Dia. G	H	L	Hole Depth P	Mounting Dimensions			Tapped Hole TØ	Holding Capacity	Wt. in Kgs
			C	D	E	F					M	N	ØS			
HTC-2326	23	23	54	28	6	23	9.5	58	168	20	42	16	5.5	M6 x 1.00	300 Kg	0.400
HTC-3025	30	25	75	50	6	25	12	70	255	25	55	30	6.5	M 8 x 1.25	1100 Kg	0.870
HTC-3545	35	45	78	68	9	46	20	90	310	30	60	45	8.5	M 12 x 1.75	2600 Kg	1.750
HTC-5065	50	70	100	75	10	85	25	123	375	35	75	50	10.5	M 16 x 2.00	4500 Kg	3.150

Straight Line Action

Model No: HTC - 1530 LH

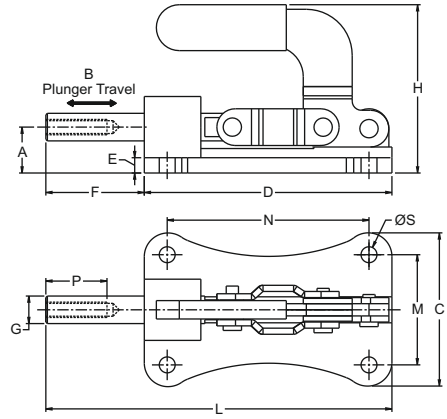
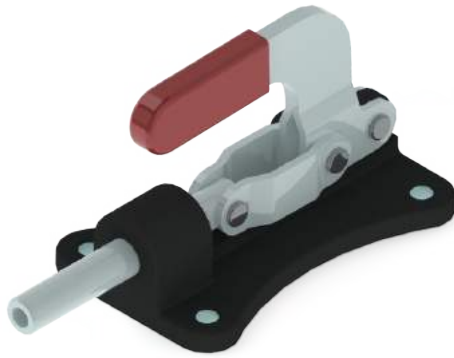

Model No.	A	Plunger Travel B	Mounting Base			F	Plunger Dia. G	H	L	Hole Depth P	Mounting Dimensions			Tapped Hole TØ	Holding Capacity	Wt. in Kgs
			C	D	E						M	N	ØS			
HTC-1530LH	15	30	51	81	5	32	9	55	112	20	36	66	5.2	M 5 x 0.80	200 Kg	0.400

HTC - Series Clamps - Low Height

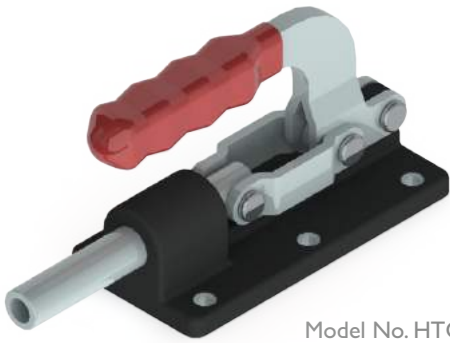

Model No. HTC - 2550 LH

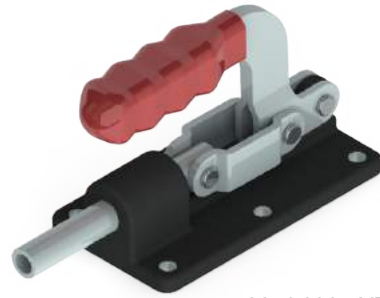

Model No. HTC - 2040 LH

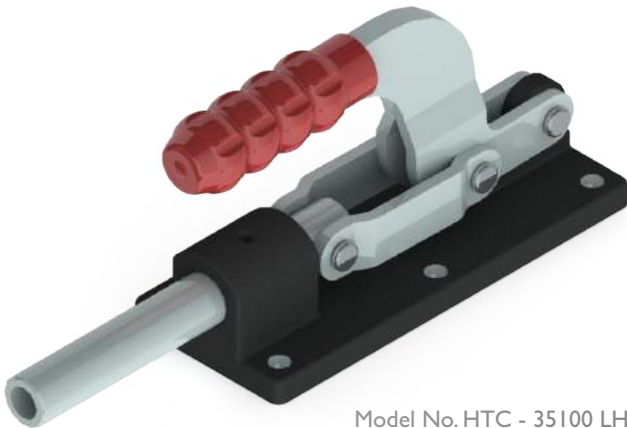

Model No. HTC - 35100 LH

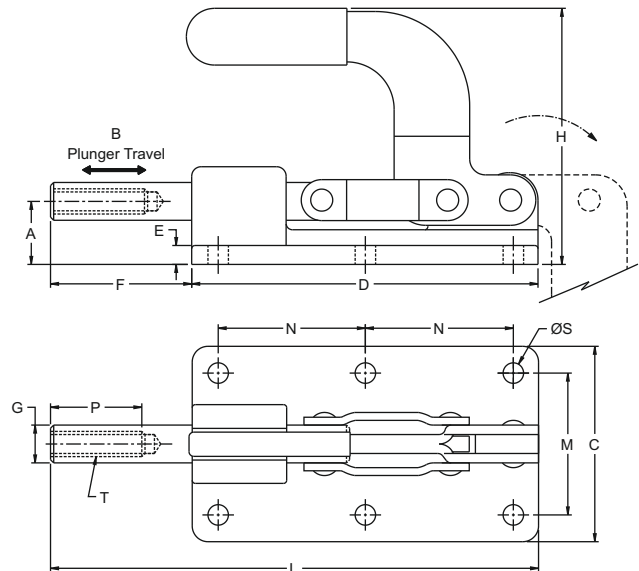

Model No.	A	Plunger Travel B	Mounting Base			F	Plunger Dia. G	H	L	Hole Depth P	Mounting Dimensions			Tapped Hole TØ	Holding Capacity	Wt. in Kgs
			C	D	E						M	N	ØS			
HTC-2040 LH	20	40	60	110	6	41	12	80	151	25	45	47	6.5	M 8 x 1.25	600 Kg	0.850
HTC-2550 LH	25	50	65	130	8	56	16	87	186	30	48	52	8.5	M 10 x 1.50	800 Kg	1.200
HTC-3075 LH	30	75	75	185	10	91	20	100	276	30	55	82.5	8.5	M 12 x 1.75	1200 Kg	2.000
HTC-35100 LH	35	100	90	215	12.5	111	25	133	326	35	66	95	10.5	M 16 x 2.00	2000 Kg	3.600

Straight Line Action

Model No: HTC - 3015 FH - R/L

Holding capacity - 200 kgs.
Weight of clamp - 0.400 kgs.

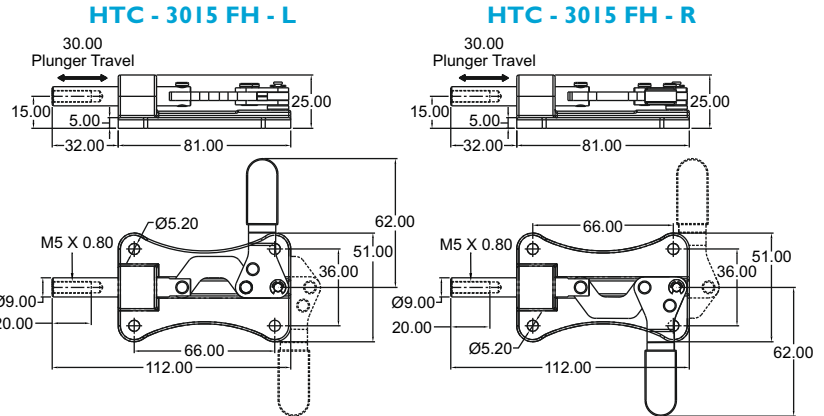
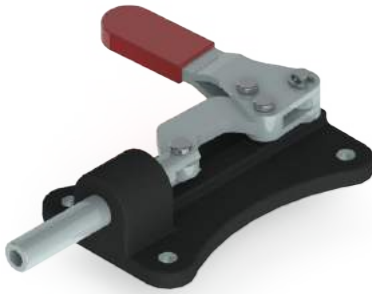

HTC - Series Clamps - Flat Handle

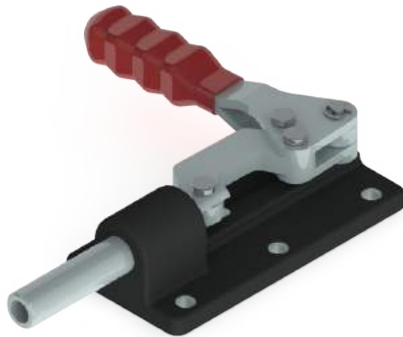

Model No. HTC - 5025 FH

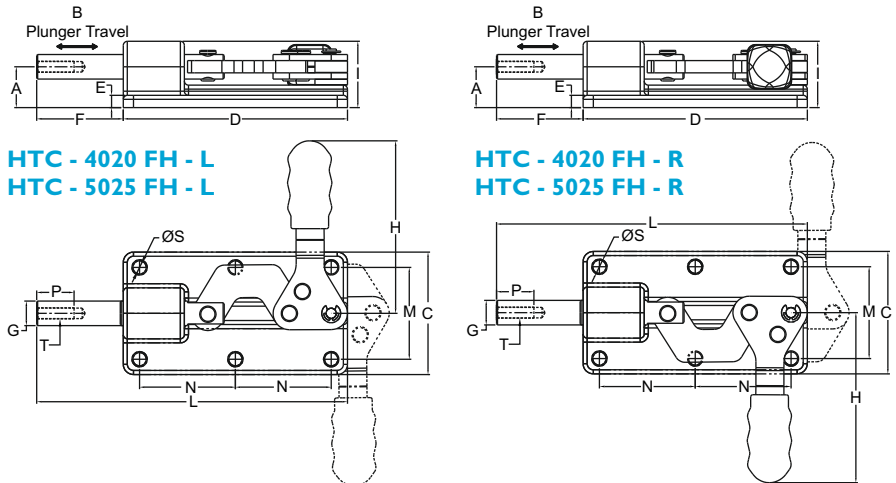

Model No.	A	Plunger Travel B	Mounting Base			F	Plunger Dia. G	H	I	L	Hole Depth P	Mounting Dimensions			Tapped Hole TØ	Holding Capacity	Wt. in Kgs
			C	D	E							M	N	ØS			
HTC-4020 FH - L HTC-4020 FH - R	20	40	60	110	6	41	12	84	32	151	25	45	47	6.5	M 8 x 1.25	600 Kg	0.850
HTC-5025 FH - L HTC-5025 FH - R	25	50	65	130	8	56	16	108	40	186	30	48	52	8.5	M 10 x 1.50	800 Kg	1.200

Model No: HTC - 650 - PS

Holding capacity - 3500 kgs.
Weight of clamp - 2.500 kgs.

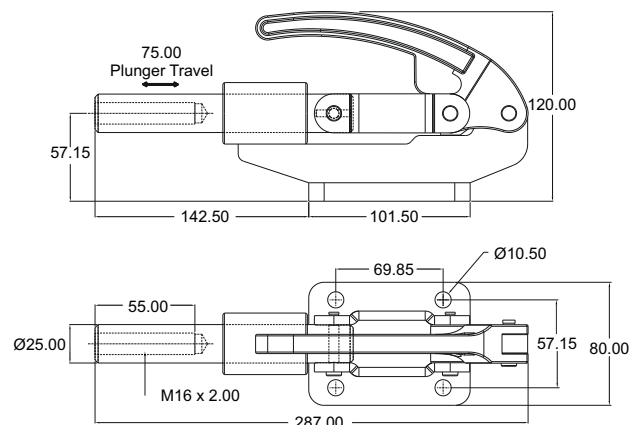

HTC - Series Clamps - Package Size



Model No. HTC - 2530 PS/BS



Model No. HTC - 2530 PS

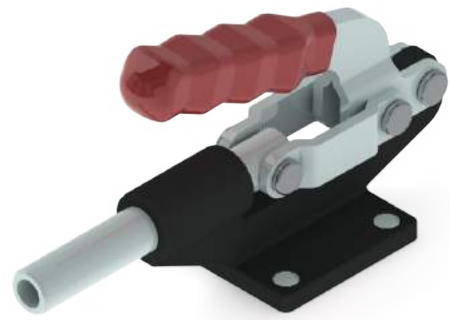
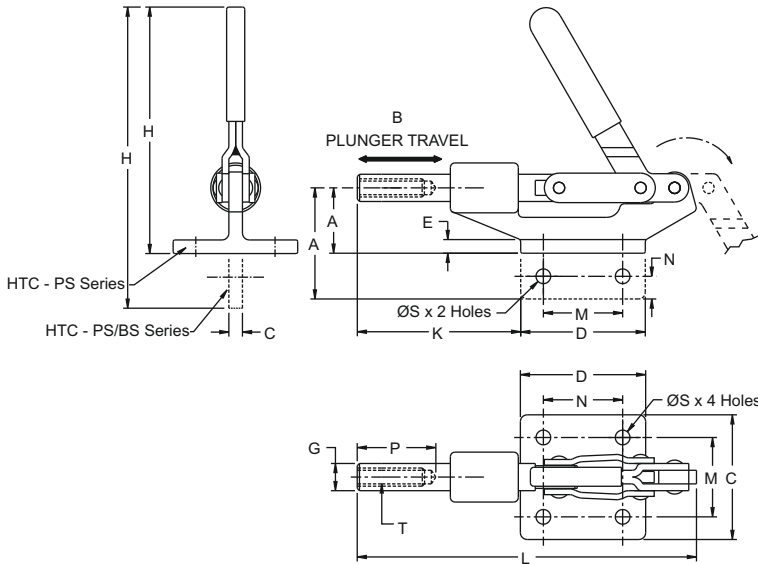

Model No. HTC - 3540 PS

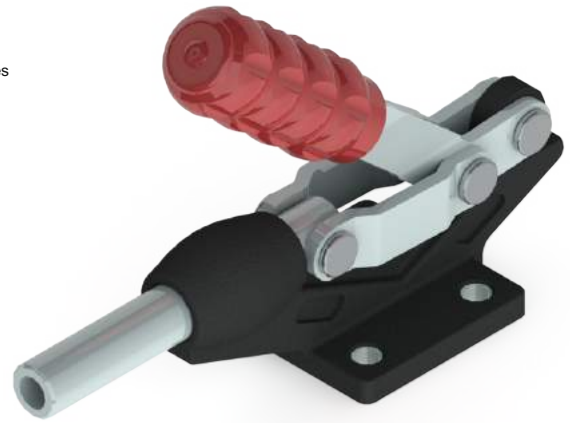

Model No. HTC - 4560 PS

Model No.	A	Plunger Travel B	Mounting Base						Plunger Dia. G	H	K	L	Hole Depth P	Tapped Hole TØ	Holding Capacity	Wt. in Kgs
			C	D	E	M	N	SØ								
HTC-1825 PS	18	25	40	40	5	28	28	5.5	9	68	45	105	20	M5 x 0.80	100 Kg	0.200
HTC-2530 PS	25	34	55	55	6	38	38	6.5	12	104	65	147	25	M 8 x 1.25	300 Kg	0.400
HTC-3540 PS	35	40	61	61	6	42	42	6.5	16	115	86	180	30	M 10 x 1.50	400 Kg	0.880
HTC-4560 PS	45	60	75	75	9	50	50	10.5	20	150	115	235	30	M 12 x 1.75	700 Kg	1.750
HTC-2530 PS/BS	49	34	6.5	55	-	35	10	6.5	12	130	68	147	25	M 8 x 1.25	300 Kg	0.375
HTC-3540 PS/BS	61	40	8	61	-	40	10	8	16	145	90	183	30	M 10 x 1.50	400 Kg	0.850
HTC-4560 PS/BS	75	60	8	75	-	50	12.5	10	20	185	122	235	30	M 12 x 1.75	700 Kg	1.650

Straight Line Action

HTC - Series Clamps - Front Mounting

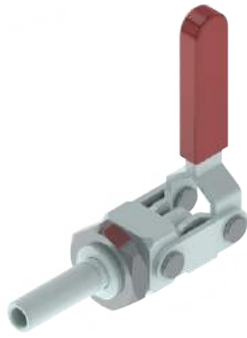

Model No. HTC -190 FM



Model No. HTC -350 FM

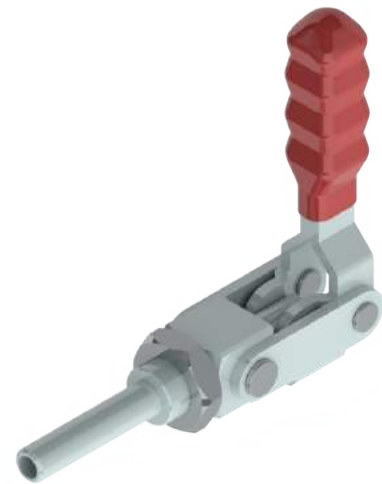
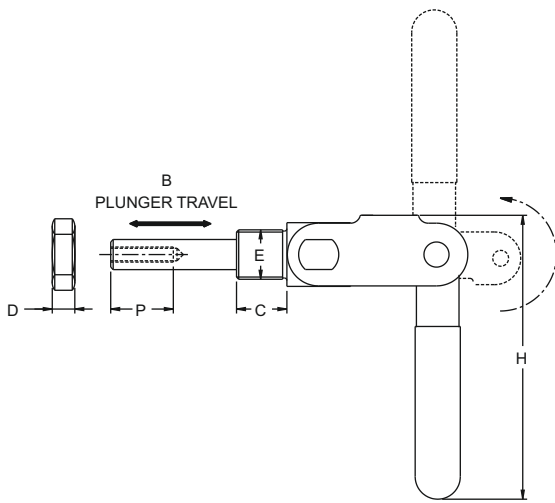

Model No. HTC - 500 FM

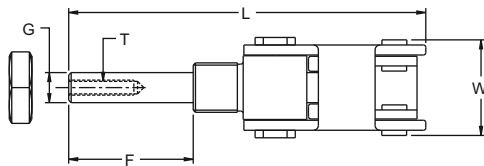

Model No. HTC - 600 FM

Model No.	Plunger Travel B	C	D	Mounting Thread Size E	F	Plunger Dia. G	H	L	P	W	Tapped Hole T	Holding Capacity	Wt. in Kgs
HTC-190 FM	24	11	6	M 16 x 2.0	30	9.5	78	77	28	25	M 6 x 1.0	50 Kg	0.130
HTC-350 FM	36	15	6	M 20 x 1.5	42	12	103	110	30	31	M 8 x 1.25	100 Kg	0.260
HTC-500 FM	39	18	9	M 20 x 1.5	53	12	120	120	30	36	M 8 x 1.25	150 Kg	0.550
HTC-600 FM	60	24	10	M 24 x 2.0	62	16	155	175	30	43	M 10 x 1.5	350 Kg	0.850

Pull Action clamps

Pull Action Clamps - PAV Series



Model No. PAV - 620

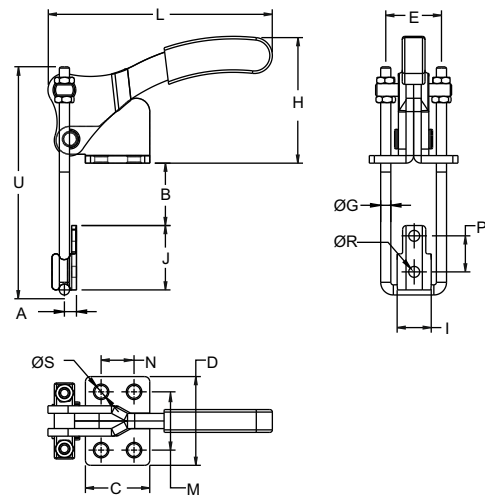

Also Available in Stainless Steel
PAV-620-SS
PAV-850-SS

Model No.	A	B		Mounting Base		E	G	H	Latch Plate		L	Mounting Dimensions					Thread Adjustment T	Holding Capacity	Wt. in Kgs
		Min	Max	C	D				I	J		M	N	P	ØS	ØR			
PAV-620	5	1	28	25.4	35	21	4	44	13.5	25	85	23	13	14.2	5.1	4.2	28	100 Kg	0.130
PAV-850	9	1	35	35	55	34	6	65	17.5	38	114	40	20	20.5	6.5	5.5	35	500 Kg	0.650

Optional U-Bolt Configuration

Use the below number for additional long U-Bolts

Model No	U Bolt Part Number	SS - U Bolt Part Number	U	T1	G1	K
PAV - 620	M49045	M49045 - SS	90	45	M4	21
PAV - 620 - M25	M411545	M411545 - SS	115			
PAV - 620 - M50	M414045	M414045 - SS	140			
PAV - 850	M613055	M613055 - SS	130	55	M6	33
PAV - 850 - M25	M615555	M615555 - SS	155			
PAV - 850 - M50	M618055	M618055 - SS	180			

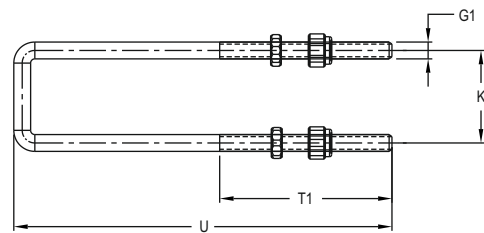

Pull Action Clamps - PA Series

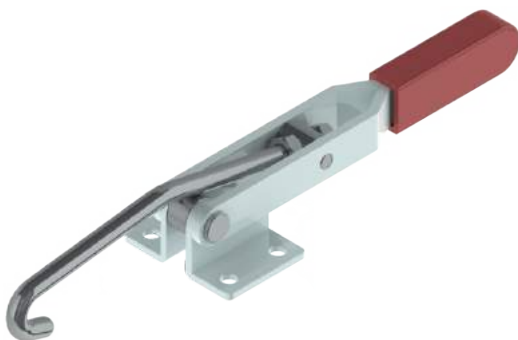

Model No. PA - 4575

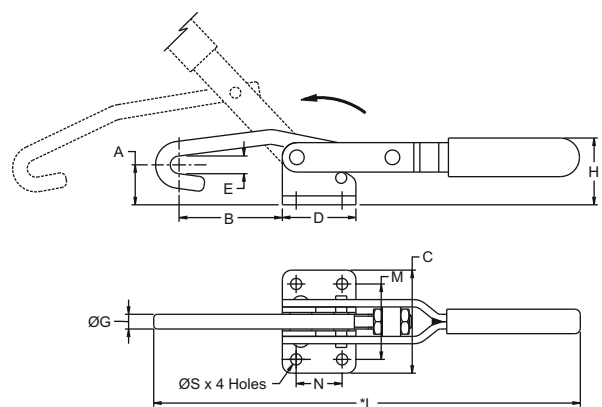

* Maximum Dimension

Model No.	A	B		Mounting Base		E	G	H	L*	Mounting Dimensions			Thread Adjustment T	Holding Capacity	Wt. in Kgs
		Min	Max	C	D					M	N	ØS			
PA-1010	12	18	30	38	26	8	6	26	150	27	16	4.5	15	75 Kg	0.120
PA-2056	20	40	55	55	40	10	8	37	245	40	25	6.5	13	200 Kg	0.380
PA-3580	35	90	115	67	49	12	10	60	365	48	30	6.5	25	400 Kg	0.650
PA-4575	45	61	90	85	54	16	12	68	374	60	29	10.5	29	500 Kg	0.950

Pull Action clamps

Pull Action Clamps - PAV - 320

Holding Capacity: 350 Kgs.
Weight: 0.320 Kgs.

Also Available
in Stainless Steel
PAV-320-SS

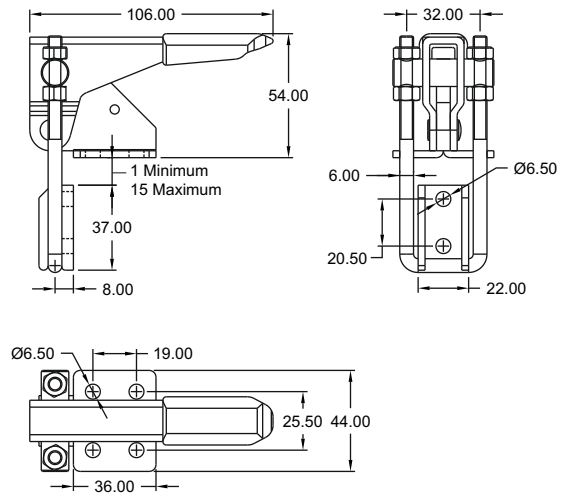
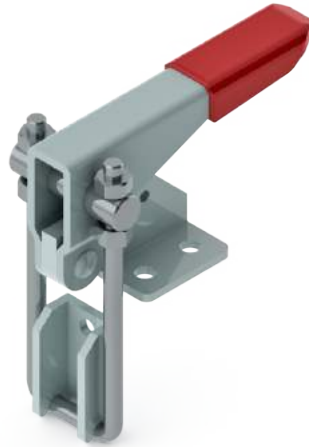

Pull Action Clamps - PA - 910318

Holding Capacity: 500 Kgs.
Weight: 0.875 Kgs.

Also Available
in Stainless Steel
PA - 910318 - SS

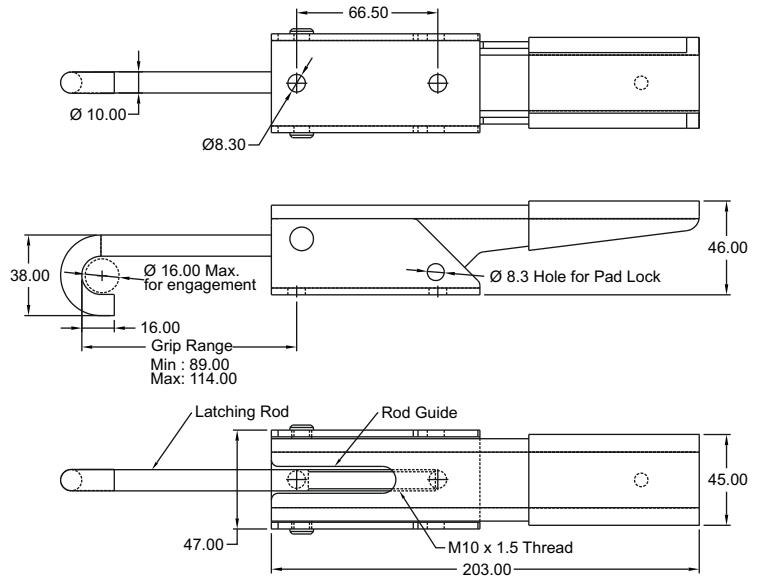
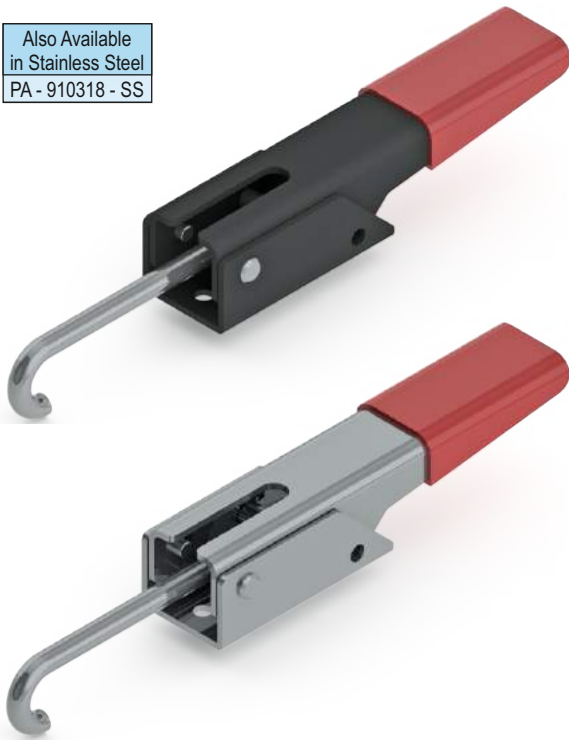

Model No: PAH - 4813

Holding Capacity - 50 kgs
Weight - 0.030 kg

Also Available
in Stainless Steel
PAH-4813-SS

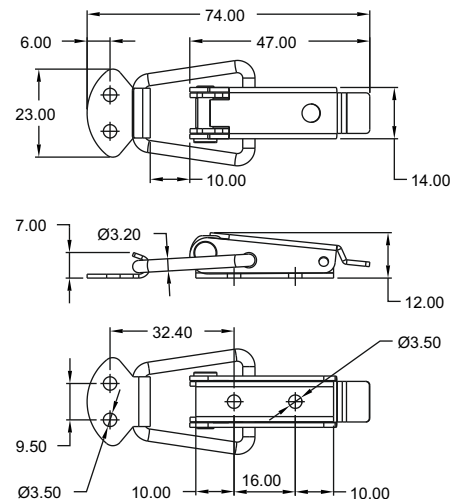

Pull Action clamps

Model No: PAV - 1065

Holding Capacity: 1,000 Kgs.
Weight: 0.800 Kgs.

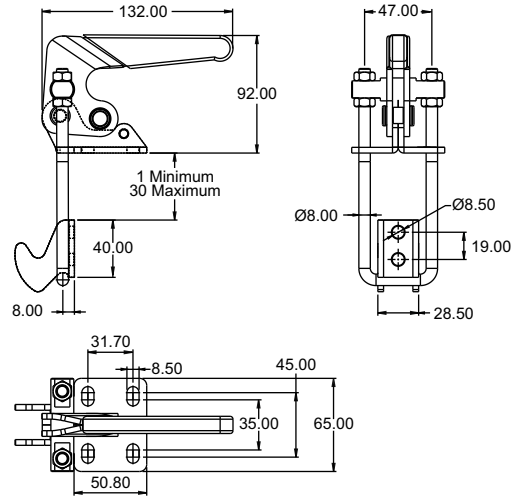

Model No: PAH - 560I

Holding Capacity: 1,000 Kgs.
Weight: 0.800 Kgs.

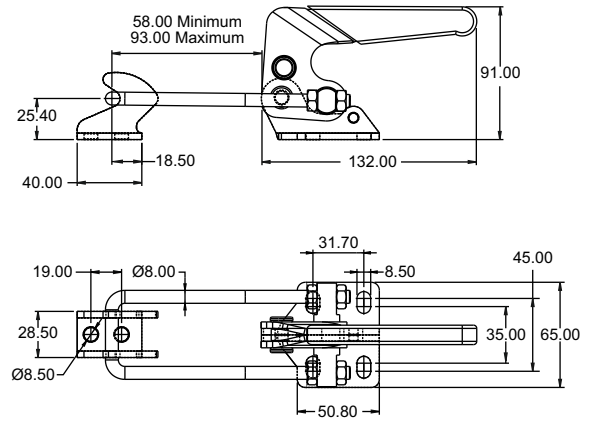

Model: PAH - 280I

Holding Capacity: 50 Kgs.
Weight: 0.100 Kgs.

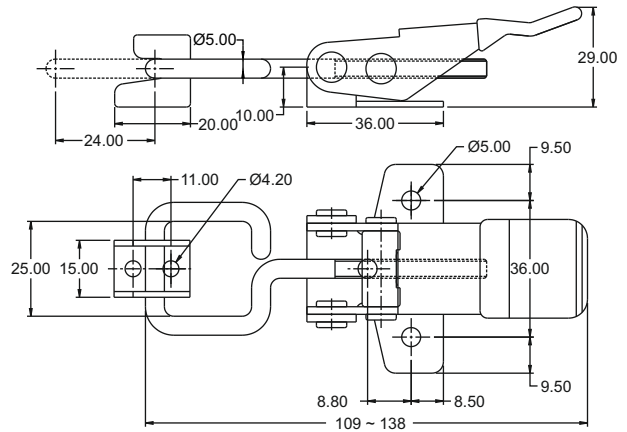
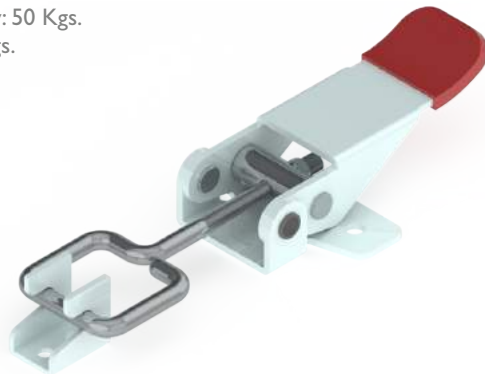

Model: PA - 325

Holding Capacity: 50 Kgs.
Weight: 0.060 Kgs.

Also Available
in Stainless Steel
PA - 325 - SS

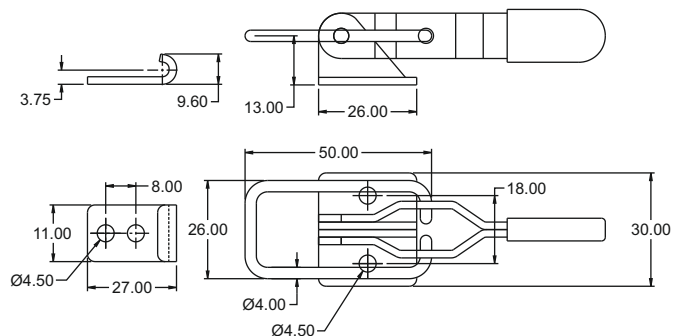
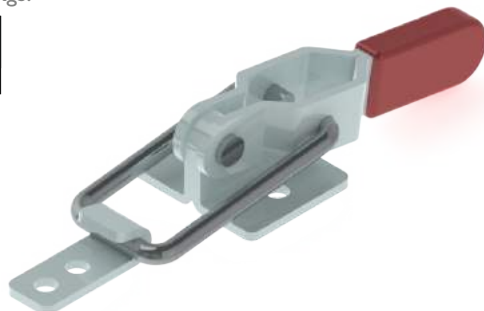

Pull Action clamps

Pull Action Clamps - PAH Series

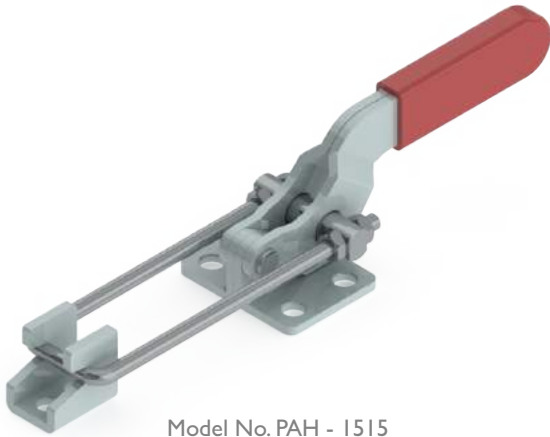

Model No. PAH - 1515

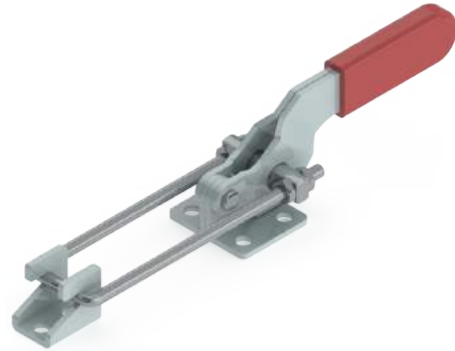

Model No. PAH - 1210



Model No. PAH - 1725

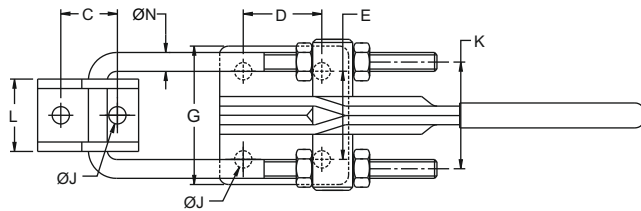
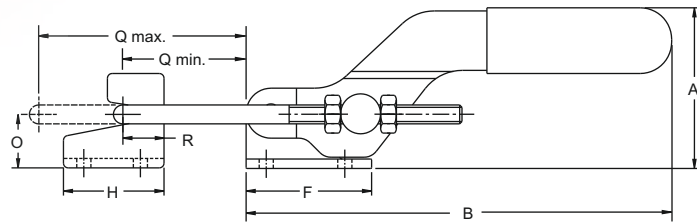

Also Available
in Stainless Steel
PAH - 1210 - SS
PAH - 1515 - SS
PAH - 1725 - SS

Model No.	Holding Capacity	Weight	Drawing Movement	Dimensions															
				A	B	C	D	E	F	G	H	ØJ	K	L	ØN	O	Q Min	Q Max	R
PAH - 1210	100 Kgs	0.100	46.0	32	96	11	16	20	26	30	20	4.5	21	15	4	12	23.0	56.0	9
PAH - 1515	200 Kgs	0.220	44.0	45	123	11	20	32	35	45	25	6.5	28	19	5	15	38.0	70.0	13
PAH - 1725	350 Kgs	0.350	50.0	52	148	18	25	28	40	45	33.5	6.5	33	23	6	16.5	40	76.0	16.5

Optional U-Bolt Configuration

Use the below number for additional long U-Bolts

Model No	U Bolt Part Number	SS - U Bolt Part Number	U	T1	G1	K
PAH - 1210	M49045	M49045 - SS	90	45	M4	21
PAH - 1210 - M25	M411545	M411545 - SS	115			
PAH - 1515	M511045	M511045 - SS	110	45	M5	28
PAH - 1515 - M25	M513545	M513545 - SS	135			
PAH - 1515 - M50	M516045	M516045 - SS	160			
PAH - 1725	M613055	M613055 - SS	130	55	M6	33
PAH - 1725 - M25	M615555	M615555 - SS	155			
PAH - 1725 - M50	M618055	M618055 - SS	180			

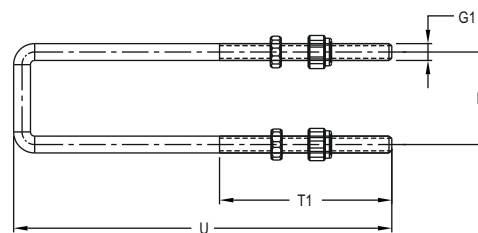

Pull Action Clamps - PAH Series

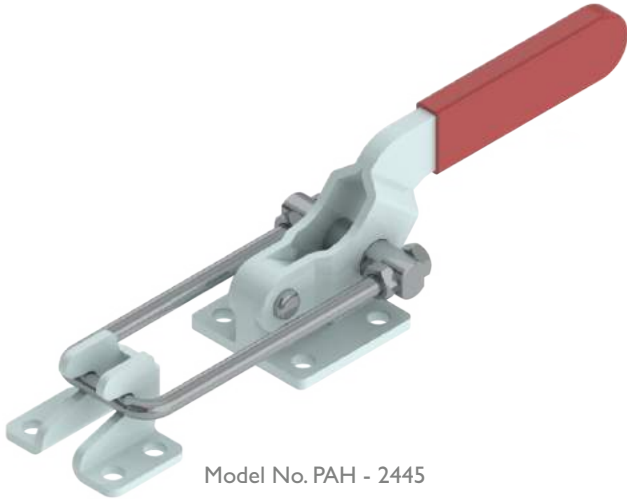

Model No. PAH - 2445



Model No. PAH - 3062

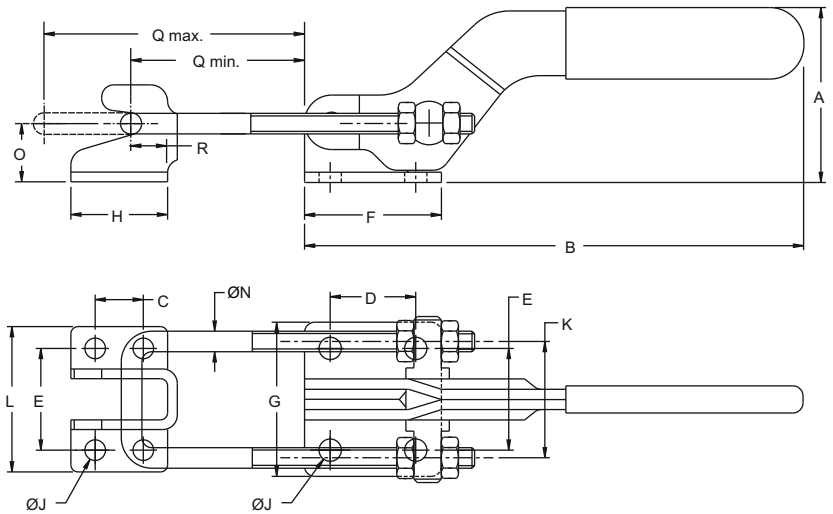

Also Available in Stainless Steel
PAH - 2445 - SS

Model No.	Holding Capacity	Weight	Drawing Movement	Dimensions															
				A	B	C	D	E	F	G	H	ØJ	K	L	ØN	O	Q Min	Q Max	R
PAH-2445	950 Kgs	0.900	88.0	61	192	22	40	42	60	60	40	8.5	47	60	8	23.5	30	67.5	15.5
PAH-3062	3000 Kgs	2.250	89.0	88	218	35	57.15	57.15	85	80	56	10.5	48	81	11	31.50	30	62	24

Optional U-Bolt Configuration
Use the below number for additional long U-Bolts

Model No	U Bolt Part Number	SS - U Bolt Part Number	U	T1	G1	K
PAH - 2445	M814570	M814570 - SS	145	70	M8	47
PAH - 2445 - M25	M817070	M817070 - SS	170			
PAH - 2445 - M50	M819570	M819570 - SS	195			
PAH - 3062	M1216585	M1216585 - SS	165	85	M12	48
PAH - 3062 - M25	M1219085	M1219085 - SS	190			
PAH - 3062 - M50	M1221585	M1221585 - SS	215			

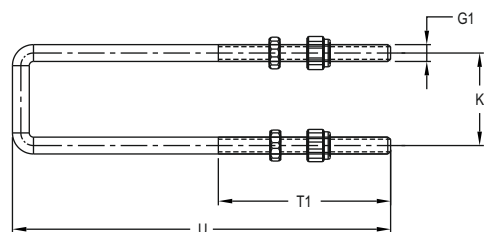

Latch clamps

Model No: PAH-30-502

Holding Capacity - 450 kgs
Weight - 0.070 kg

Also Available
in Stainless Steel
PAH-30-502-SS

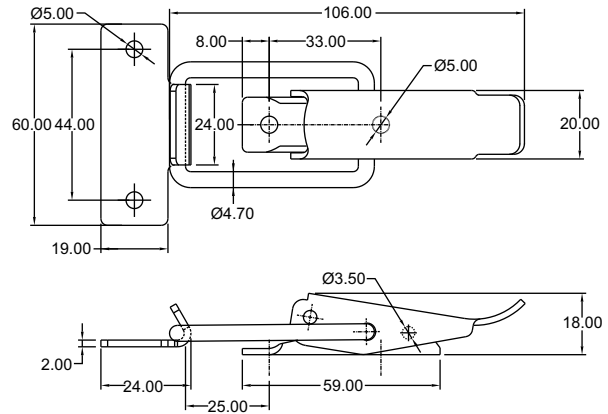

Model No: PAH-30-570

Holding Capacity - 450 kgs
Weight - 0.078 kg

Also Available
in Stainless Steel
PAH-30-570-SS

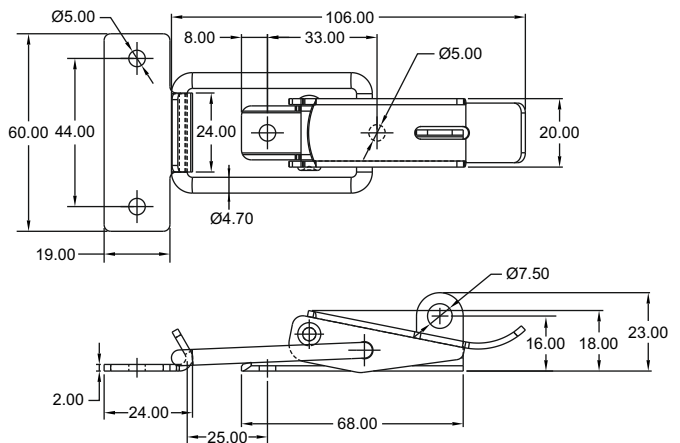
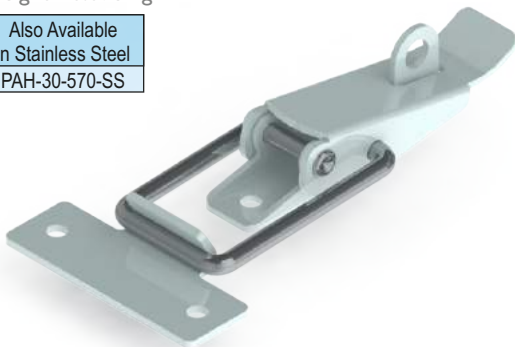

Model No: PAH-30-588LP

Holding Capacity - 450 kgs
Weight - 0.085 kg

Also Available
in Stainless Steel
PAH-30-588LP-SS

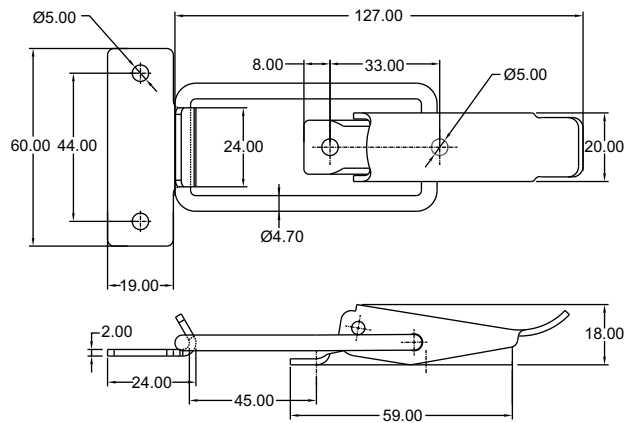
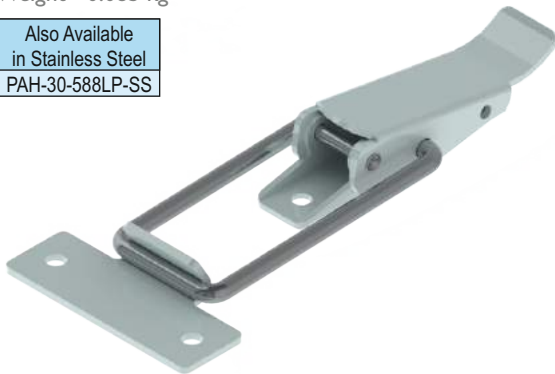

Model No: PAH-30-590

Holding Capacity - 450 kgs
Weight - 0.085 kg

Also Available
in Stainless Steel
PAH-30-590-SS

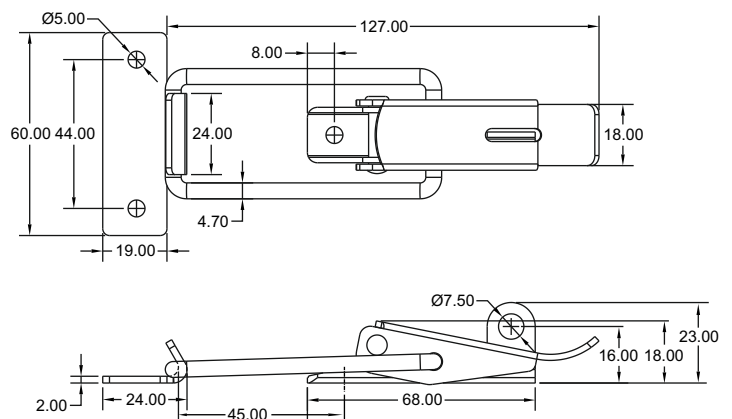

Latch clamps

Model No: PAH-40-502

Holding Capacity - 250 kgs

Weight - 0.100 kg

Also Available in Stainless Steel
PAH-40-502-SS

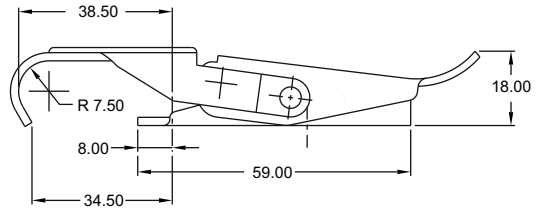
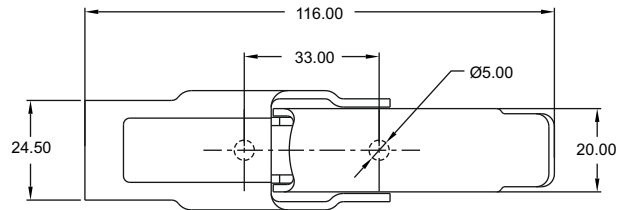

Model No: PAH-40-570

Holding Capacity - 250 kgs

Weight - 0.110 kg

Also Available in Stainless Steel
PAH-40-570-SS

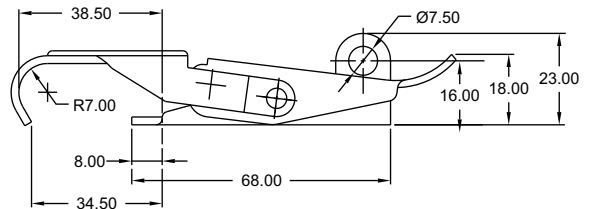
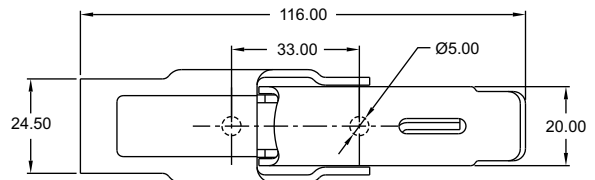
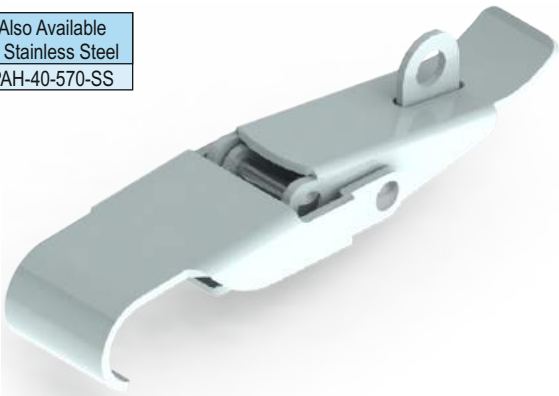

Model No: PAH-50-502

Holding Capacity - 250 kgs

Weight - 0.120 kg

Also Available in Stainless Steel
PAH-50-502-SS

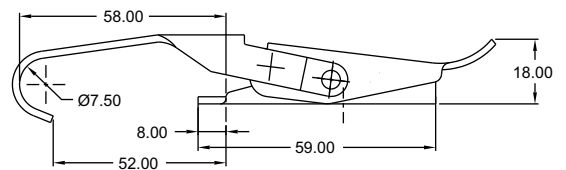
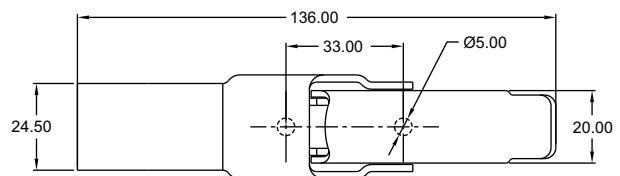
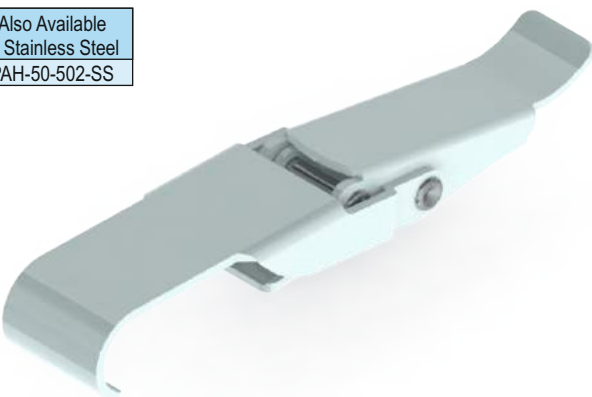

Latch clamps

Model No: PAH-50-570

Holding Capacity - 250 kgs
Weight - 0.125 kg

Also Available
in Stainless Steel
PAH-50-570-SS

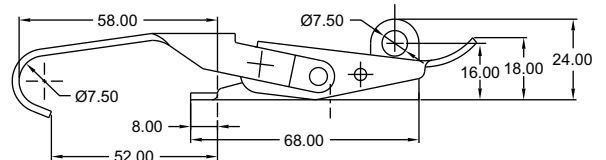
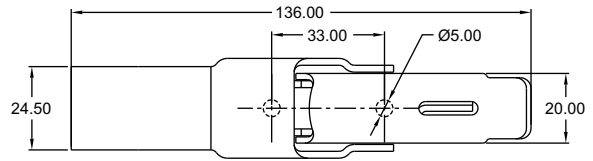

Model No: PAH-60-2600

Holding Capacity - 300 kgs
Weight - 0.150 kg

Also Available
in Stainless Steel
PAH-60-2600-SS

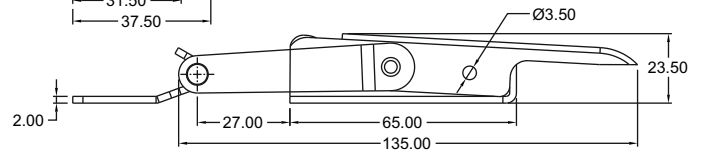
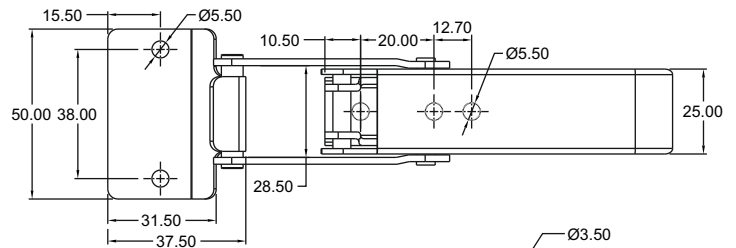
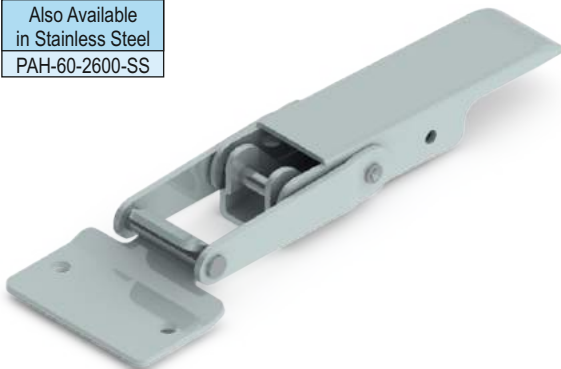

Model No: PAH-70-2600

Holding Capacity - 150 kgs
Weight - 0.170 kg

Also Available
in Stainless Steel
PAH-70-2600-SS

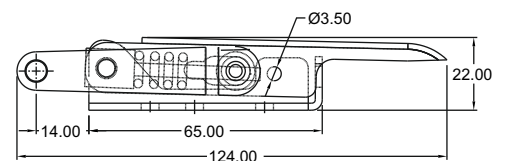
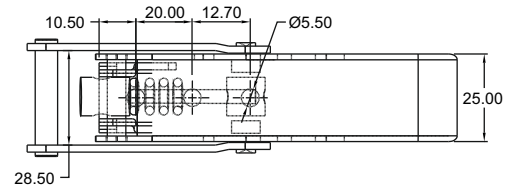
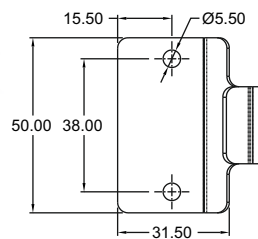
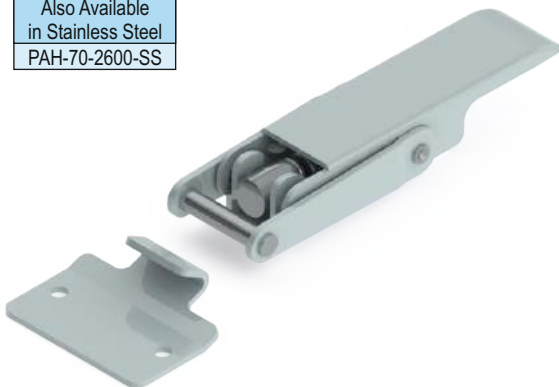

Latch clamps

Model No: PAH-33-1260

Holding Capacity - 450 kgs
Weight - 0.110 kg

Also Available
in Stainless Steel
PAH-33-1260-SS

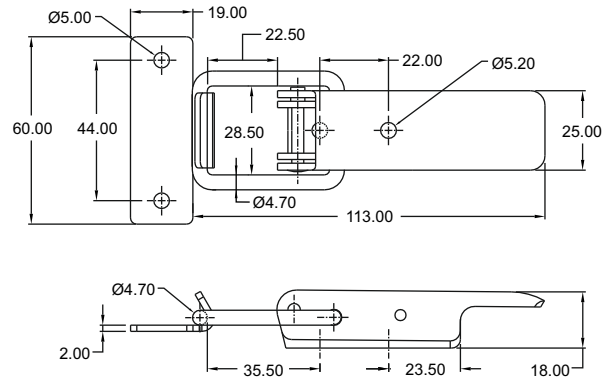

Model No: PAH-38-1260-TRIG with Additional Locking Mechanism

Holding Capacity - 450 kgs
Weight - 0.120 kg

Also Available
in Stainless Steel
PAH-38-1260-TRIG-SS

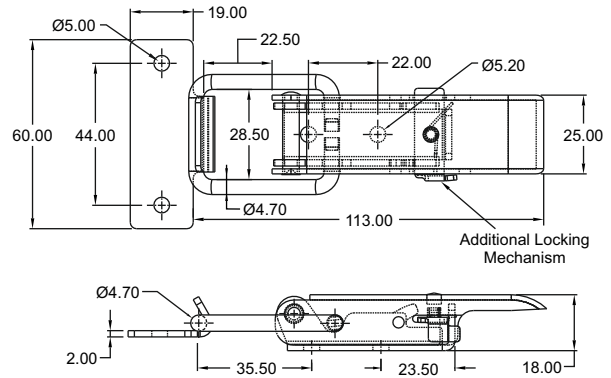

Model No: PAH-33-5880

Holding Capacity - 450 kgs
Weight - 0.120 kg

Also Available
in Stainless Steel
PAH-33-5880-SS

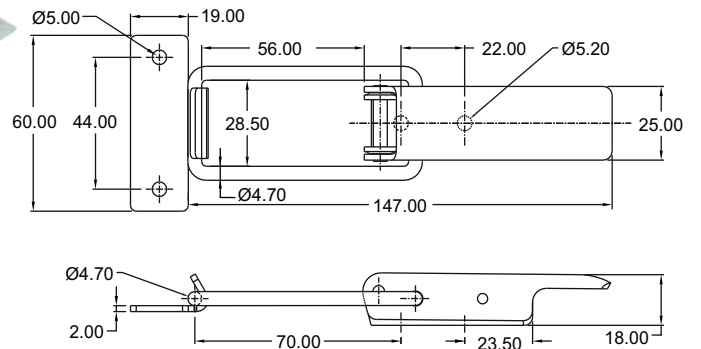

Model No: PAH-38-5880-TRIG with Additional Locking Mechanism

Holding Capacity - 450 kgs
Weight - 0.130 kg

Also Available
in Stainless Steel
PAH-38-5880-TRIG-SS

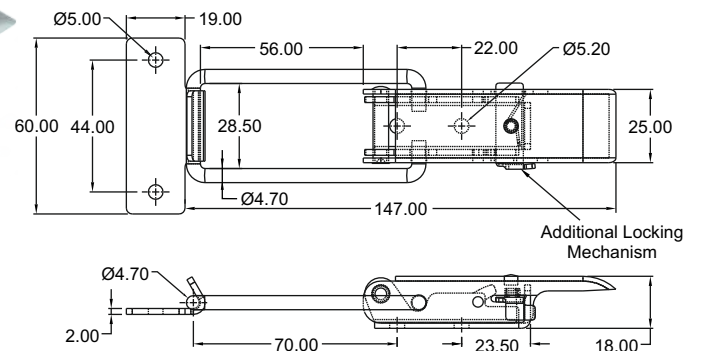

Latch clamps

Model No: PAH-43-4000

Holding Capacity - 2000 kgs
Weight - 0.470 kg

Also Available
in Stainless Steel
PAH-43-4000-SS

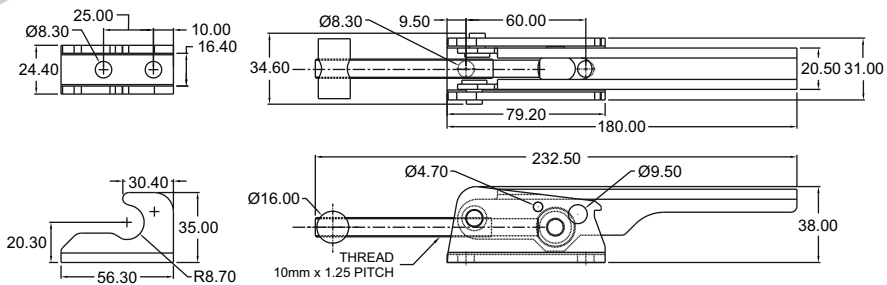
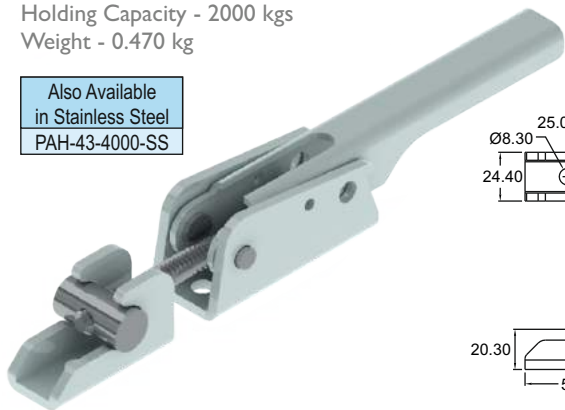

Model No: PAH-44-4000-TRIG with Additional Locking Mechanism

Holding Capacity - 2000 kgs
Weight - 0.490 kg

Also Available
in Stainless Steel
PAH-44-4000-TRIG-SS

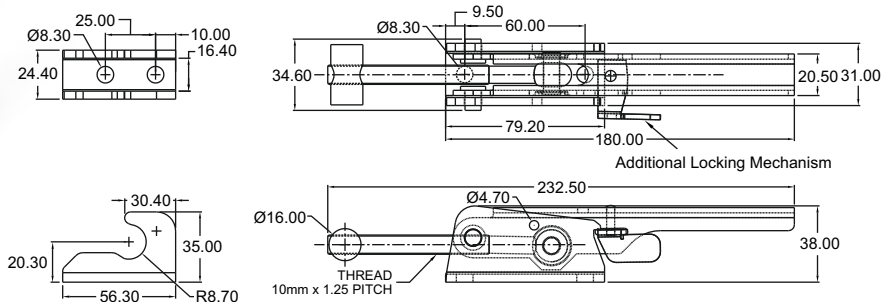
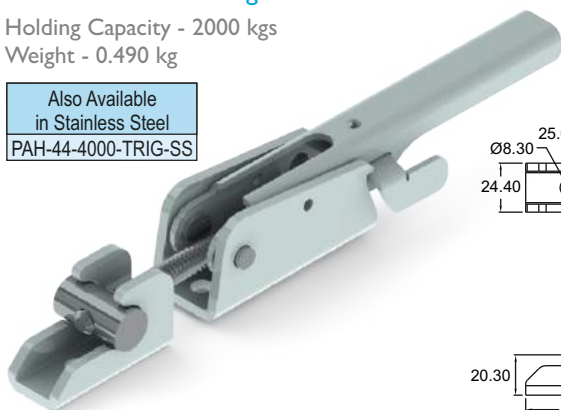

Model No: PAH-43-4000-150

Holding Capacity - 2000 kgs
Weight - 0.500 kg

Also Available
in Stainless Steel
PAH-43-4000-150-SS

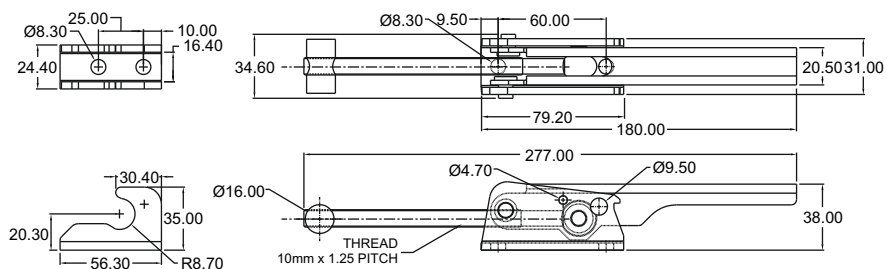

Model No: PAH-44-4000-150-TRIG with Additional Locking Mechanism

Holding Capacity - 2000 kgs
Weight - 0.520 kg

Also Available
in Stainless Steel
PAH-44-4000-150-TRIG-SS

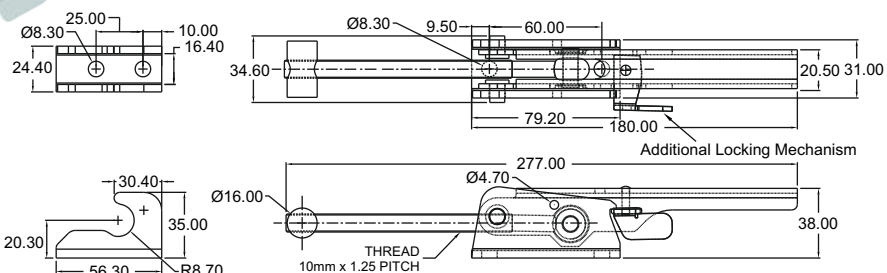
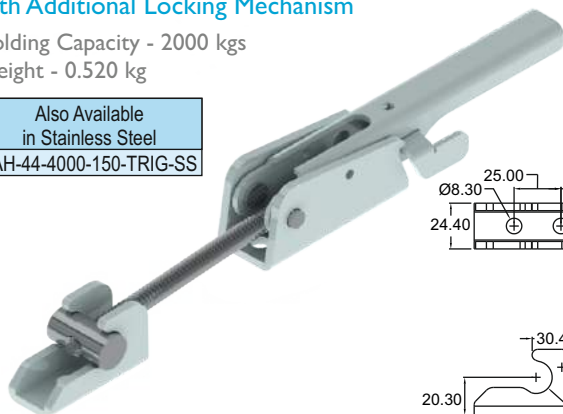

Latch clamps

Model No: PAH-CT-0313

Holding Capacity - 10 kgs
Weight - 0.017 kgs

Also Available
in Stainless Steel
PAH-CS-0313-SS

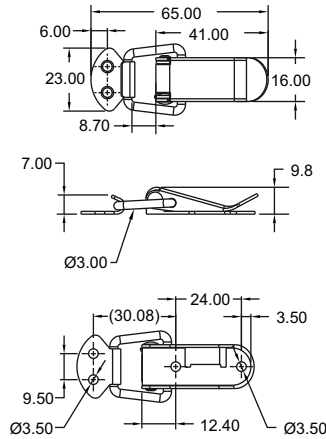

Model No: PAH-CT-10103

Holding Capacity - 25 kgs
Weight - 0.024 kgs

Also Available
in Stainless Steel
PAH-CS-10103-SS

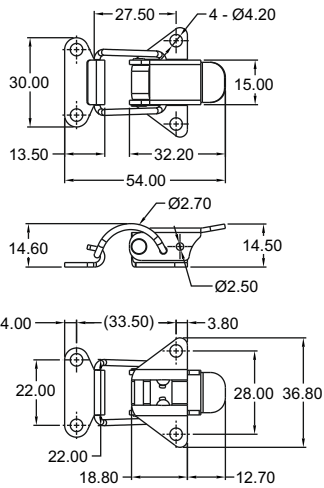

Model No: PAH-CT-10104

Holding Capacity - 25 kgs
Weight - 0.026 kgs

Also Available
in Stainless Steel
PAH-CS-10104-SS

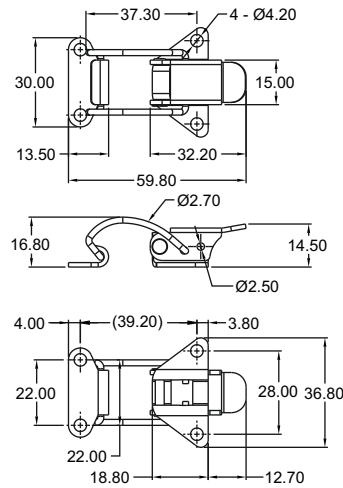

Model No: PAH-CT-10105

Holding Capacity - 25 kgs
Weight - 0.028 kgs

Also Available
in Stainless Steel
PAH-CS-10105-SS

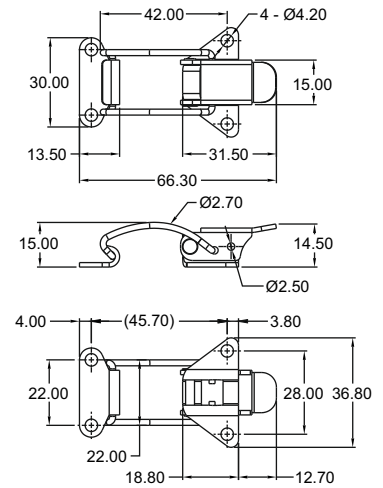

Model No: PAH-CT-1113

Holding Capacity - 20 kgs
Weight - 0.025 kgs

Also Available
in Stainless Steel
PAH-CS-1113-SS

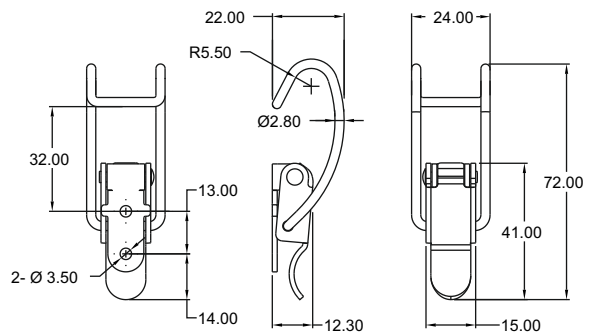

Latch clamps

Spring Loaded Pull Action Clamps

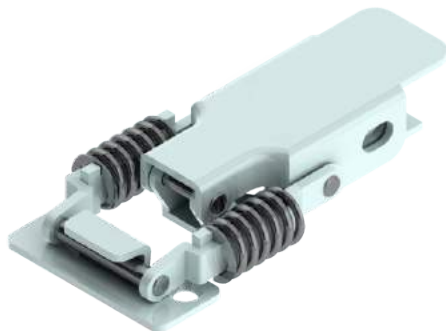

Model No. PAH - CT - 0120

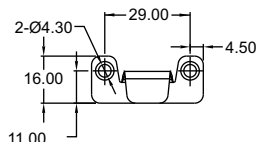
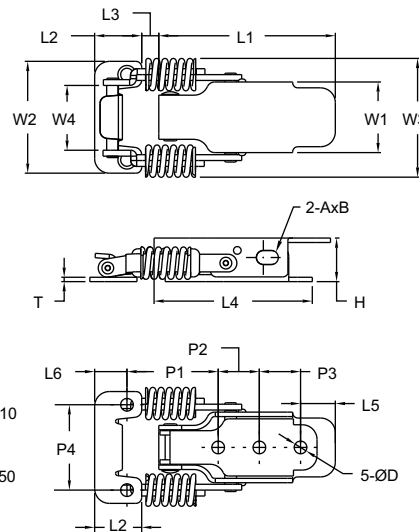

Also Available
in Stainless Steel
PAH - CS - 0120 - SS
PAH - CS - 0130 - SS

Model No.	Holding Capacity	Weight	Dimensions																	
			L1	L2	L3	L4	L5	L6	W1	W2	W3	W4	H	T	P1	P2	P3	P4	D	A x B
PAH - CT - 0120	50 Kgs	0.070	60	16	5 - 8	54	11.8	11	24	38	40	22	15	1.5	31-34	14	14	29	4.3	7.5 x 4.7
PAH - CT - 0130	50 Kgs	0.140	80	19	6 - 9	68.5	18.5	13	32	50	50	28	18	2.0	38-41	18	18	38	5.3	10 x 6.5

Model No: PAH-CT-21227

Holding Capacity - 80 kgs
Weight - 0.080 kgs
Feature: Additional Locking Mechanism

Also Available
in Stainless Steel
PAH-CS-21227-SS

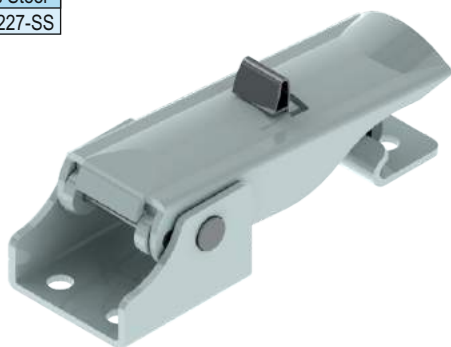

Model No: PAH-CT-21237

Holding Capacity - 80 kgs
Weight - 0.080 kgs
Feature: Additional Locking Mechanism

Also Available
in Stainless Steel
PAH-CS-21237-SS

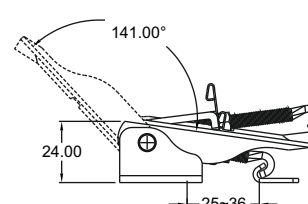
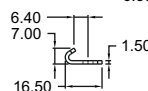
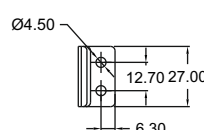
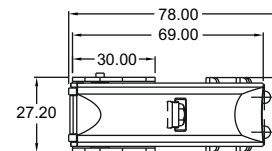
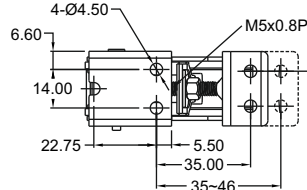
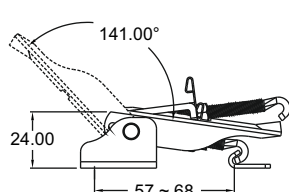
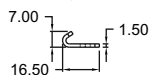
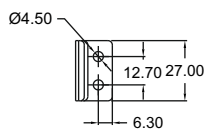
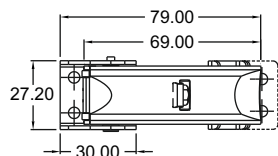
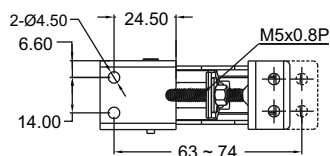
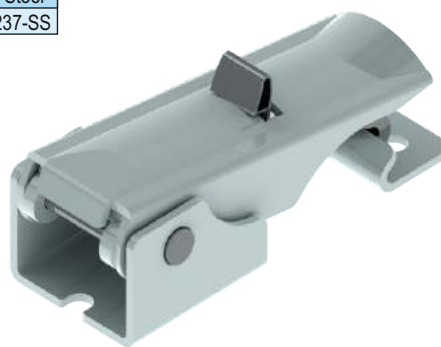

Latch clamps

Pull Action Clamps

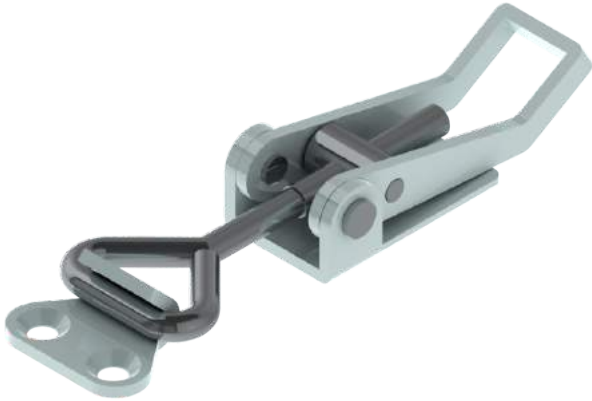

Model No. PAH - CT - 0222

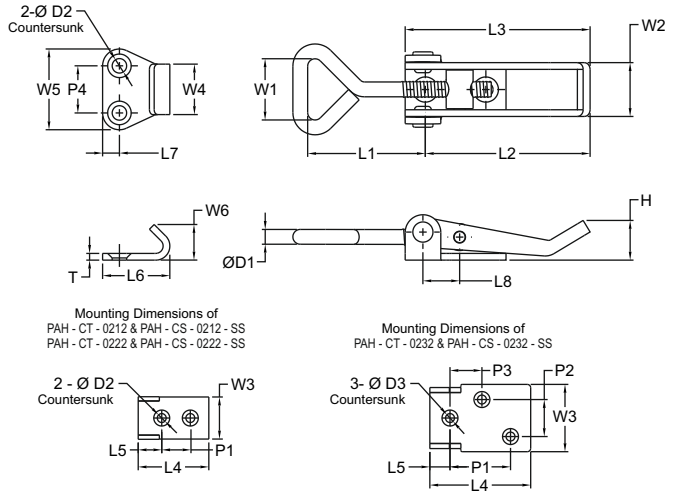

Mounting Dimensions of
PAH - CT - 0212 & PAH - CS - 0212 - SS
PAH - CT - 0222 & PAH - CS - 0222 - SS

Mounting Dimensions of
PAH - CT - 0232 & PAH - CS - 0232 - SS

Also Available in Stainless Steel
PAH - CS - 0212 - SS
PAH - CS - 0222 - SS
PAH - CS - 0232 - SS

Model No.	Holding Capacity	Weight	Dimensions																										
			L1	L2	L3	L4	L5	L6	L7	L8	W1	W2	W3	W4	W5	W6	H	P1	P2	P3	P4	D1	D2	D3	T				
PAH - CT - 0212	75 Kgs	0.045	22 - 42	49	55	30	6	20	5	11	18.2	16	16	15	24	10.6	11.8	18	-	-	14	4.4	4.3	4.3	2				
PAH - CT - 0222	90 Kgs	0.090	41 - 65	53	67	42	14	22	6	12	21.4	20	25	17	30	13.3	16.4	17	-	-	17	5.3	5.3	5.3	2.5				
PAH - CT - 0232	100 Kgs	0.210	46 - 70	86	98	60	12	29	7.5	15	34	30	40	22	45	17	19.4	36	22	19	22	7.0	5.3	5.3	3				

Pull Action Clamps with locking arrangement

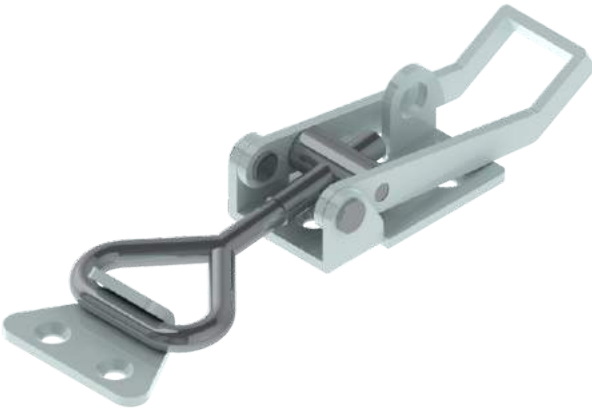

Model No. PAH - CT - 0220

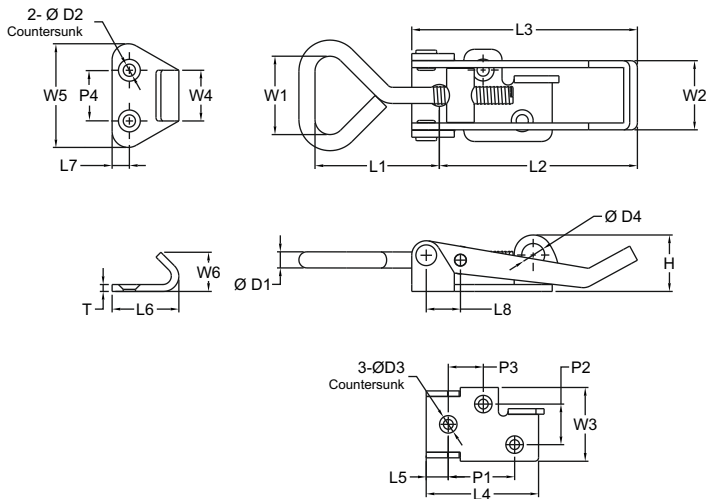

Also Available in Stainless Steel
PAH - CS - 0210 - SS
PAH - CS - 0220 - SS
PAH - CS - 0230 - SS

Model No.	Holding Capacity	Weight	Dimensions																										
			L1	L2	L3	L4	L5	L6	L7	L8	W1	W2	W3	W4	W5	W6	H	P1	P2	P3	P4	D1	D2	D3	D4	T			
PAH - CT - 0210	75 Kgs	0.050	22 - 42	47	55	38	8	20	5	11	18.2	16	30	15	24	10.6	17	20	16	11	14	4.4	4.3	4.3	6	2			
PAH - CT - 0220	90 Kgs	0.100	41 - 65	53	67	50	14	22	6	12	21.4	20	32	17	30	13.3	19	27	18	11	17	5.3	5.3	5.3	6	2.5			
PAH - CT - 0230	100 Kgs	0.225	46 - 70	85	98	61	12	29	7.5	15	34	30	40	22	45	17	24.5	36	22	19	22	7.0	5.3	5.3	10	3			

Squeeze Action Clamps

Toggle Pliers - TP Series



Model No.TP - 4570

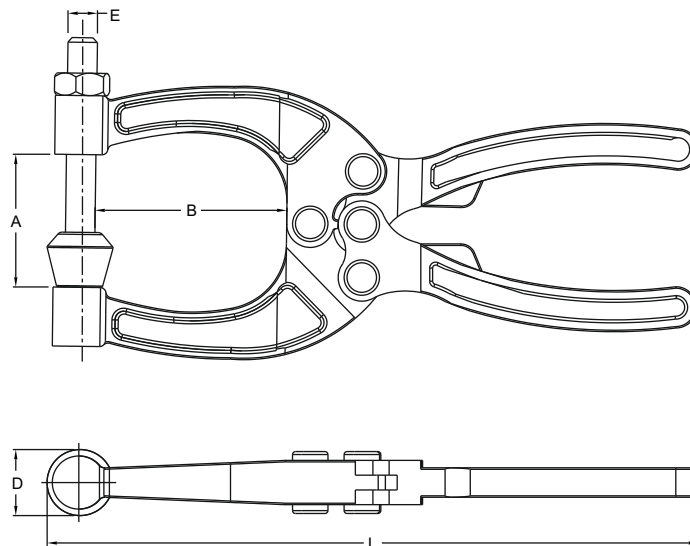

Model No.TP - 2528



Model No.TP - 3245

MODEL	A	B	DØ	E	L	HOLDING CAPACITY	WT.IN KGS.
TP - 2528	25	28	13	M 6 X 1.00	128	100 Kg	0.220
TP - 3245	32	45	15	M 8 x 1.25	195	200 Kg	0.570
TP - 4570	45	70	18	M 10 x 1.50	220	400 Kg	0.640

VG Series

Steel-Smith introduces the all new VG Plier series. This new generation plier series expands the wide portfolio of toggle clamps and clamping equipments. Designed and developed for easy, single hand operation, the VG Plier series come as a great aid in tool room and fixturing applications.

The II member strong family of VG Pliers can take on multiple tasks with remarkable ease. Be it delicate wood work or the extreme welding applications. Each plier comes with a spindle assembly which enables the adjustment of pressure. The spring-loaded mechanism provided at one end of the plier ensures quick release at just a touch of finger.

What's more, with an ever innovative team at the helm of our relentless R & D department, you can always expect newer additions. And If you have a specialised application area, we are equipped to deliver customised design solutions.



VG-3070 Flat Jaw Plier

Having a 60mm wide jaw this Plier has a complete surface contact in the clamped position, distributing pressure evenly on the clamped surfaces. The Plier locks with a powerful grip making it ideal as a sheet metal tool and for applications such as bending, forming and crimping.



Model No.VG-3070

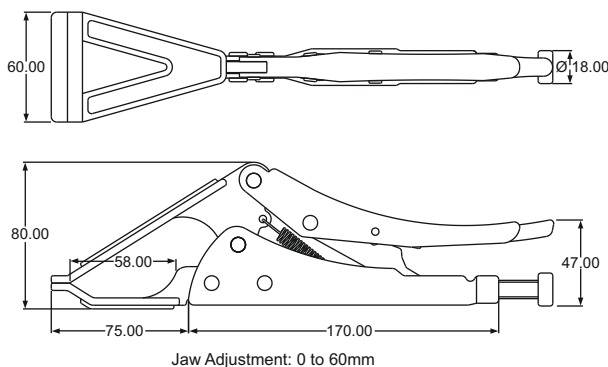

VG-3060 U Jaw Deep Throat Plier

This Plier is designed with a "U" Shaped Jaw, which gives it a deeper throat depth in the clamped position. Permits the clamping of adjacent joints and perfect visibility when welding.



Model No.VG-3060 U

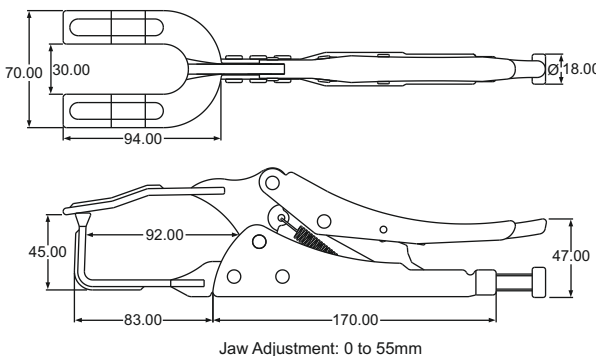

VG-8070 C Jaw Plier

This clamp features wide arms that reach over or around most obstructions. The Plier had a throat depth of 73mm and a jaw depth of 100mm. These pliers can easily replace the conventional C clamps in applications such as welding, spotting, assembling etc.



Model No.VG-8070 C

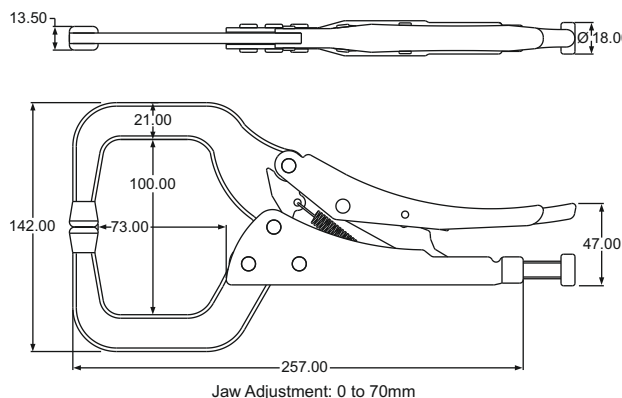

V. G. Series

VG-10764 C Jaw Plier

Dimensionally this Plier is same as the VG 8070 Plier with an exception of the swivel pad. The swivel pads adjust parallel to the work piece. The Plier had a throat depth of 68mm and a jaw depth of 100mm.



Model No.VG-10764 C

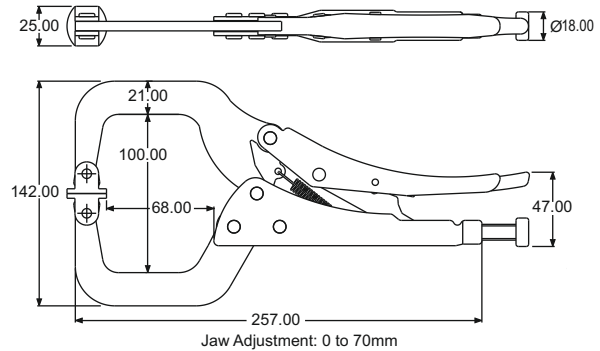

VG-150100 C Jaw Plier

This Plier has the deepest jaw depth i.e. 150mm, to reach over flanges or obstructions on the work piece. Swivel pads are a standard feature & they adjust parallel to the work piece. The Plier had a throat depth of 100mm and a jaw depth of 150mm.



Model No.VG-150100 C

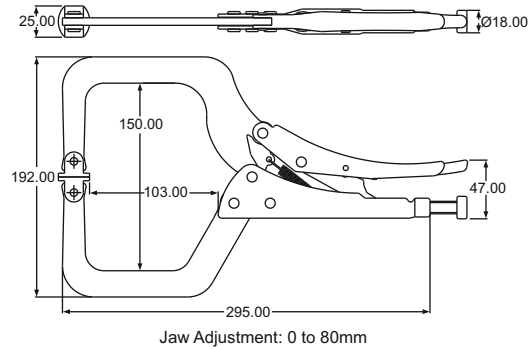

VG-80200 C Jaw Plier

This is the longest Plier available with Steel Smith. It has a reach of 200mm, which enables it to reach a distant clamping area. The swivel pads adjust parallel to the work piece. The Plier has an adjustment of 0 to 160mm also the highest in the series.



Model No.VG-80200 C

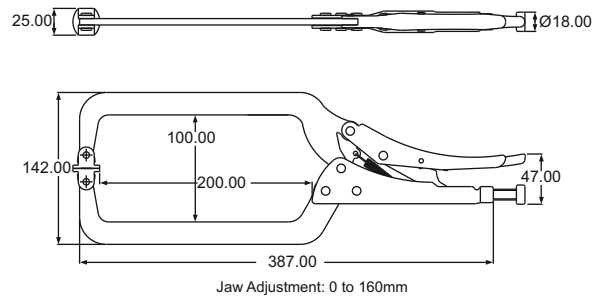

VG-14075 C Jaw Plier

The unique feature of this Plier is that it has a preset Jaw distance of the 75mm. It is specially designed for clamping larger sections. The Plier has an adjustment of 0 to 130mm, so it can clamp a section of 200mm thickness Swivel pads are a standard feature & they adjust parallel to the work piece.

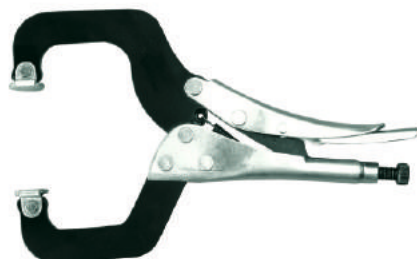

Model No.VG-14075 C

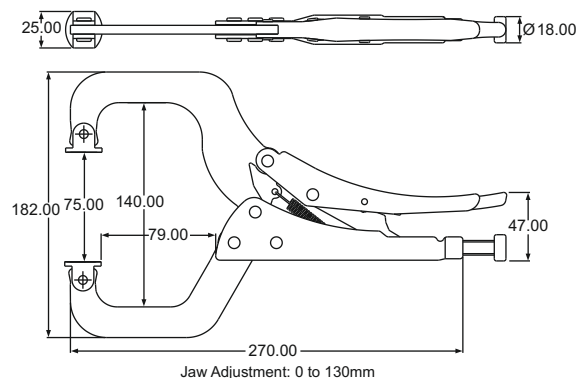

Tapered Jaw Pliers
VG-3075 & VG-50125

These Pliers have a slim compact design for easy reach into tight corners or small work areas. The pliers are available in 2 different sizes. VG-3075 has a jaw depth of 75mm whereas VG-50125 has a depth of 125mm.



Model No. VG-3075

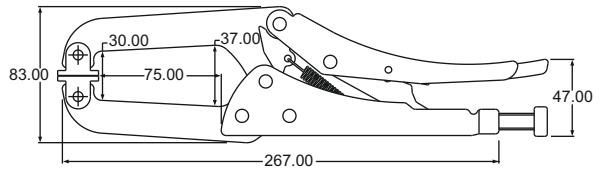
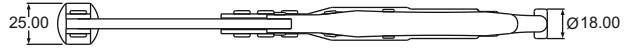

Jaw Adjustment: 0 to 60mm

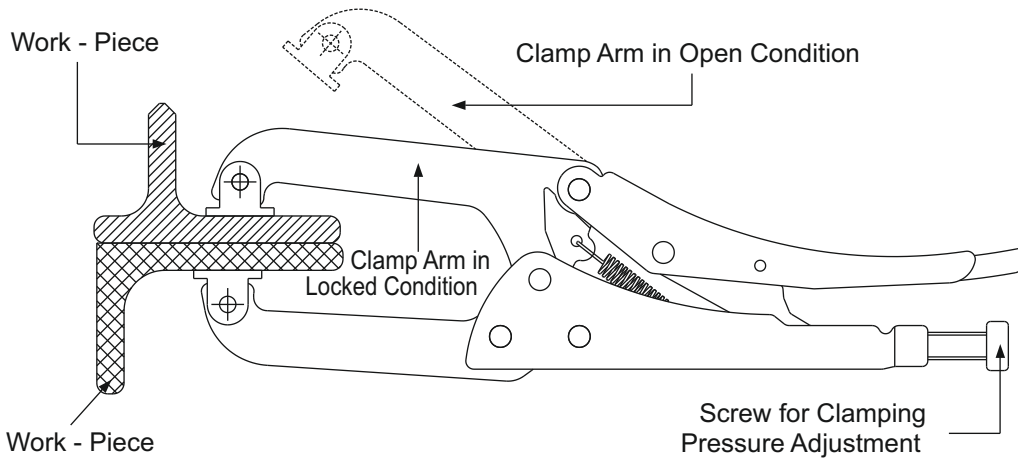

Model No. VG-50125

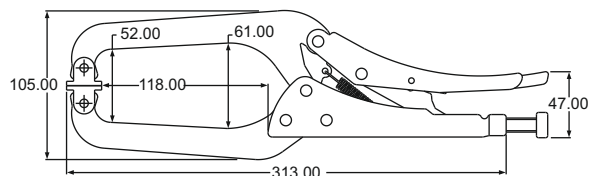

Jaw Adjustment: 0 to 85mm

V. G. Series

Single Jaw Pliers

VG-5090 OA and VG-95100 OA

The Single Jaw Pliers have only the Top Jaw and the machine bed or the fixture base plate becomes the second jaw of the Plier. The Plier holds the work-piece against the bench and takes up very little space. This is an excellent Plier for drilling, fitting or gluing applications. The trigger release enables quick opening and closing of the Plier.



Model No.VG-5090 OA

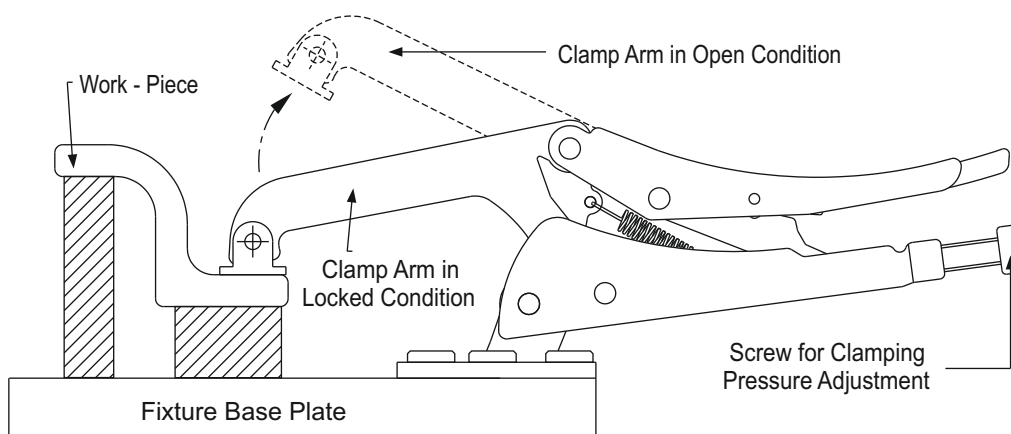
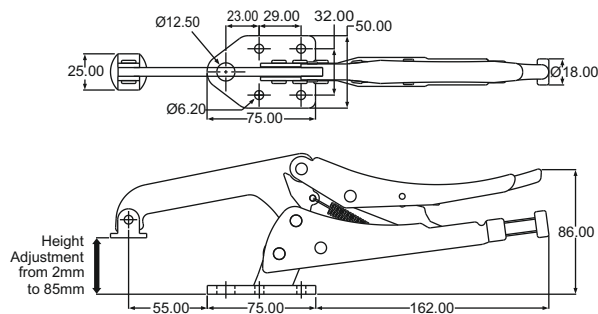

Model No.VG-95100 OA

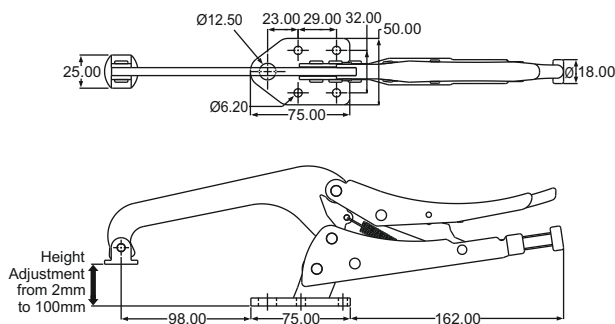

F Clamps

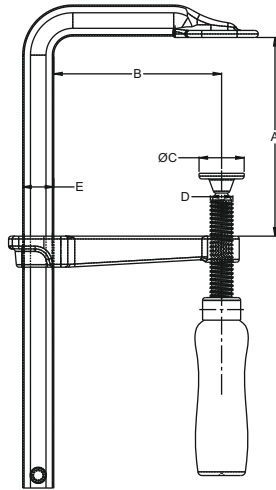

G-C Series F Clamps with Wooden Handle

MODEL NO	A MAX JAW OPENING	B THROAT DEPTH	C SWIVEL PAD	D ACME SCREW	E RAIL SIZE	WEIGHT IN KGS.
G12C	120	60	22	12	13.5 x 6.5	0.30
G16C	160	80	25	14	16.0 x 7.5	0.50
G20C	200	100	32	16	19.5 x 7.5	0.88
G25C	250	120	32	16	22.0 x 10.5	1.23
G30C	300	140	38	18	25.0 x 12.0	1.85
G40C	400	175	38	18	27.0 x 13.0	2.57
G60C	600	175	38	18	27.0 x 13.0	3.06
G80C	800	175	38	18	27.0 x 13.0	3.55

SG-C Series F Clamps with Wooden Handle

MODEL NO	A MAX JAW OPENING	B THROAT DEPTH	C SWIVEL PAD	D ACME SCREW	E RAIL SIZE	WEIGHT IN KGS.
SG40C	400	120	38	18	25 x 12	1.91
SG50C	500	120	38	18	25 x 12	2.12
SG60C	600	120	38	18	25 x 12	2.33
SG80C	800	120	38	18	27 x 13	3.26
SG100C	1000	120	38	18	27 x 13	3.75
SG125C	1250	120	38	18	27 x 13	4.36
SG150C	1500	120	38	18	27 x 13	4.98

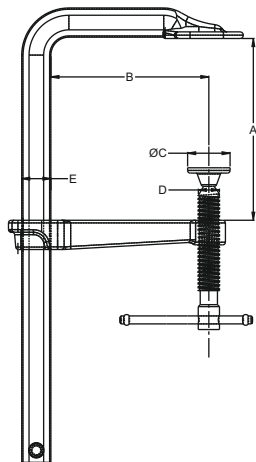

G-C Series F Clamps with Tommy Bar Handle

MODEL NO	A MAX JAW OPENING	B THROAT DEPTH	C SWIVEL PAD	D ACME SCREW	E RAIL SIZE	WEIGHT IN KGS.
G16CS	160	80	25	14	16.0 x 7.5	0.50
G20CS	200	100	32	16	19.5 x 7.5	0.88
G25CS	250	120	32	16	22.0 x 10.5	1.23
G30CS	300	140	38	18	25.0 x 12.0	1.85
G40CS	400	175	38	18	27.0 x 13.0	2.57
G60CS	600	175	38	18	27.0 x 13.0	3.06
G80CS	800	175	38	18	27.0 x 13.0	3.55

SG-C Series F Clamps with Tommy Bar Handle

MODEL NO	A MAX JAW OPENING	B THROAT DEPTH	C SWIVEL PAD	D ACME SCREW	E RAIL SIZE	WEIGHT IN KGS.
SG40CS	400	120	38	18	25 x 12	1.91
SG50CS	500	120	38	18	25 x 12	2.12
SG60CS	600	120	38	18	25 x 12	2.33
SG80CS	800	120	38	18	27 x 13	3.26
SG100CS	1000	120	38	18	27 x 13	3.75
SG125CS	1250	120	38	18	27 x 13	4.36
SG150CS	1500	120	38	18	27 x 13	4.98

F Clamps

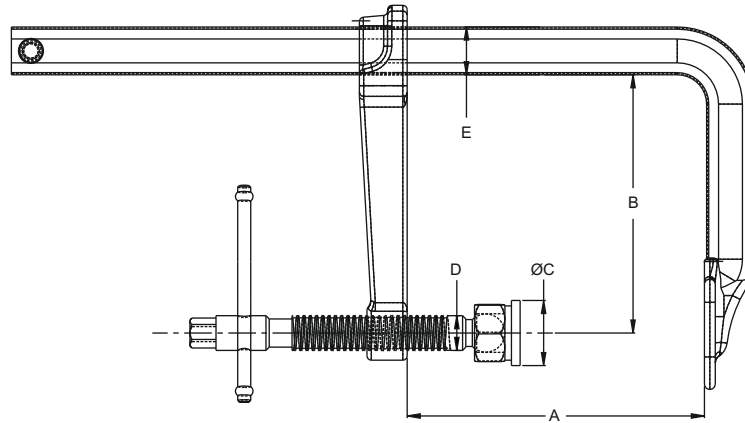

SG-C12 Series F Clamps with Tommy Bar Handle & Removable Adapter

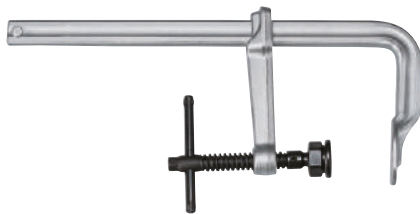

MODEL NO	A MAX JAW OPENING	B THROAT DEPTH	C SWIVEL PAD	D ACME SCREW	E RAIL SIZE	WEIGHT IN KGS.
S20C12	200	120	38	18	27 x 13	1.97
S25C12	250	120	38	18	27 x 13	2.09
S30C12	300	120	38	18	27 x 13	2.21
S40C12	400	120	38	18	27 x 13	2.46
S50C12	500	120	38	18	27 x 13	2.71
S60C12	600	120	38	18	27 x 13	2.96
S100C12	1000	120	38	18	27 x 13	3.88

GS-C Series Heavy Duty F Clamps with Tommy Bar Handle & Removable Adapter

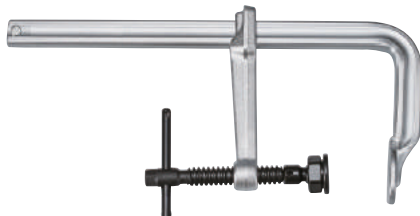

MODEL NO	A MAX JAW OPENING	B THROAT DEPTH	C SWIVEL PAD	D ACME SCREW	E RAIL SIZE	WEIGHT IN KGS.
GS25C	250	120	41	20	30 x 15	2.76
GS30C	300	140	41	20	30 x 15	3.03
GS40C	400	120	41	20	30 x 15	3.24
GS50C	500	140	41	20	30 x 15	3.66
GS60C	600	120	41	20	30 x 15	3.87
GS80C	800	140	41	20	30 x 15	4.62
GS100C	1000	120	41	20	30 x 15	5.15
GS125C	1250	120	41	20	30 x 15	5.94
GS150C	1500	120	41	20	30 x 15	6.65

SS-C Series Extra Heavy Duty F Clamps with Tommy Bar Handle & Removable Adapter

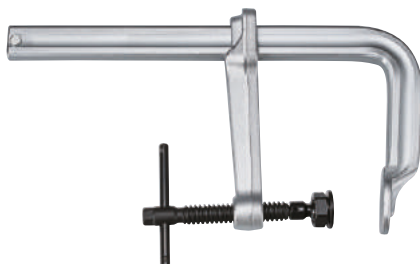

MODEL NO	A MAX JAW OPENING	B THROAT DEPTH	C SWIVEL PAD	D ACME SCREW	E RAIL SIZE	WEIGHT IN KGS.
SS30C	300	175	41	22	40 x 20	5.50
SS40C	400	175	41	22	40 x 20	6.06
SS50C	500	175	41	22	40 x 20	6.62
SS60C	600	175	41	22	40 x 20	7.18
SS80C	800	175	41	22	40 x 20	8.30
SS100C	1000	175	41	22	40 x 20	9.43
SS125C	1250	175	41	22	40 x 20	10.83
SS150C	1500	175	41	22	40 x 20	12.07

AUTOMOTIVE CLAMPS

Steel-Smith has designed the Automotive clamps to be adaptable & durable, and to withstand abuse in heavy duty applications. They are ideally used in automotive manufacturing & other production environment which require high clamping forces & long service life. These clamps have a unique design that offers the designer both complete design flexibility & clamping force. These clamps comprise of a very strong & rugged toggle mechanism. The clamping arm & handle which are provided with the clamp can be welded at the desired angle to suit the individual requirements of work pieces. All components are of first grade steel & the axles are hardened running in either hardened bushes or directly in close tolerance holes. The clamps are finished olive green passivation

The Versatility of Steel- Smith Clamps allows handle positioning of 120° maximum angular positioning arc through 360° orbital arc. The clamping arm has 120° maximum angular positioning arc. These exceptional features make Steel-Smith H.V. Series clamps ideal for many job requirements otherwise requiring special designed clamps.

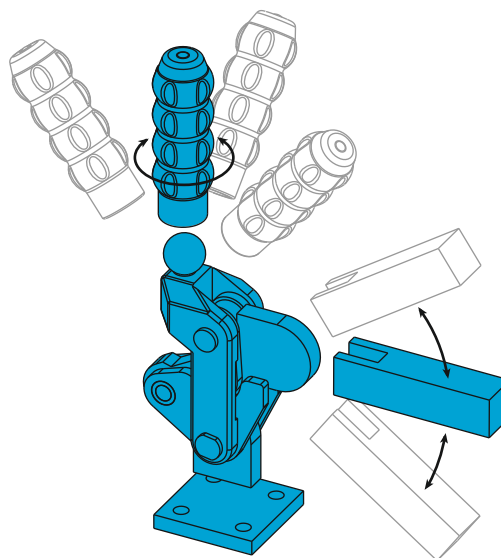

Automotive Clamps with Additional Locking Mechanism

Steel-Smith introduces its latest range of Automotive clamps with Additional Locking Mechanism, this mechanism ensures that the clamp remains locked in any condition.

In order to unclamp, the mechanism must be first released.

In this Series this mechanism will hold the clamping arm in both the closed and open positions, so that it is protected against unintentional opening or closing through vibration or if the clamp is mounted overhead.

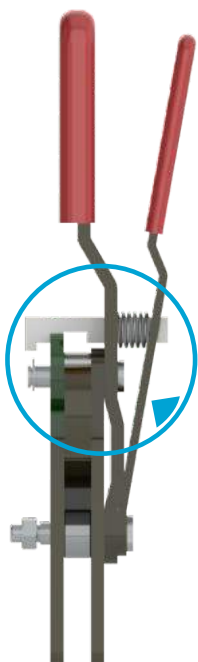

Additional Locking Mechanism

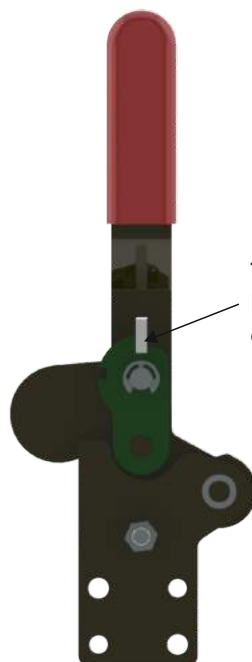

The additional locking Mechanism ensures that the clamp remains locked

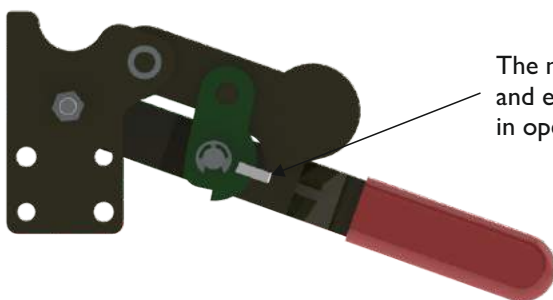

The mechanism engages in the base and ensures that the clamp remains in open position

Automotive Clamps

H.V. SERIES TOGGLE CLAMPS - SWIVEL BASE

The H.V. Series Toggle Clamps comprise of a basic toggle mechanism onto which can be welded at a desired angle, the clamping arm and handle which are supplied with the clamp. These models feature a swivel base which is welded at the desired angle to the mechanism, then welded either directly to the fixture or alternatively to a base which is offered as an accessory for bolt mounting. The clamping arm exhibits 180 degree opening angle which enables easy unloading of workpiece. Accurately machined steel components are equipped with hardened bushes & pivot pins. Three sizes basic linkages are available which allows the designer complete flexibility to position the base, clamp arm handle and weld them to suit the application.

Installation:

When welding the swivel base of the clamp mechanism ensure that the full length of the adjoining surfaces are welded. Ensure that the welding splatters do not enter the slots which form the forward stop of the mechanism.



Model No.HV - BII - 500



Assembled Swivel Base Clamp

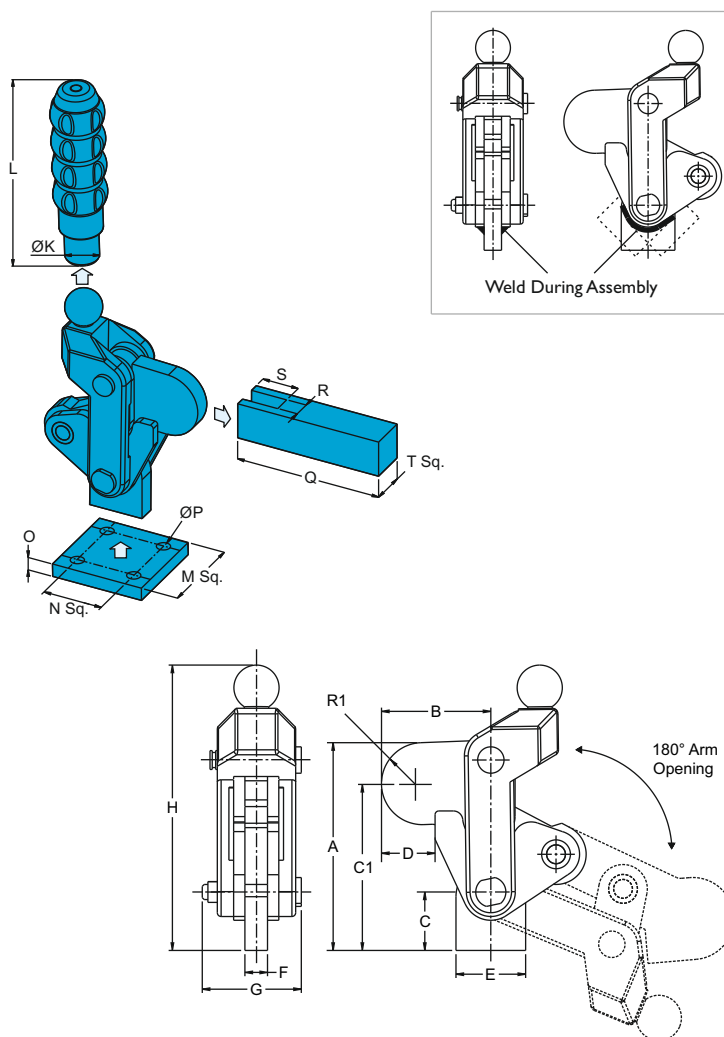

Clamp is supplied in separate parts



Anatomy of Swivel Base Clamp

Model No.	A	B	C	C1	D	E	F	G	H	K	L	M Sq.	N Sq.	O	P	Q	R	S	T Sq.	R1	Holding Capacity	Wt. In Kgs
HV-BII-100	59	30	19	48	15	20	6	29	85	12	50	35	20	6	5.5	50	6	13	12	11	200 Kgs.	0.330
HV-BII-200	76	40	22	60	16	24	8	41	106	16	75	45	29	6	6.5	75	8	15	20	16	500 Kgs.	0.810
HV-BII-300	90	50	26	73	24	29	10	45	127	22	90	50	30	8	6.5	90	10	21	22	17	700 Kgs.	1.370
HV-BII-500	110	58	31	89	30	37	12	58	152	22	100	63	40	10	8.7	100	12	25	25	22	1200 Kgs.	2.300
HV-BII-1000	136	77	37	109	42	58	15	61	182	22	125	80	55	10	10.5	125	15	32	30	27	2500 Kgs.	3.700

H.V. SERIES TOGGLE CLAMPS - BASE STRAIGHT

The Base Straight Series is identical to the Swivel Base Series with the exception of the base design. For situations where a vertical surface is used to mount the clamp a straight base can be used. The B.S. series clamps have more height under the clamping bar in the closed position. The clamp opens a full 180° to completely clear the work area. The handle and the clamping arm supplied with the clamp can be welded at a desired angle. Similar to the Swivel Base Series clamps the bushes and pivot pins are hardened for higher efficiency of the clamp. The clamps are available in five sizes.



Model No. HV - BII - 500 BS

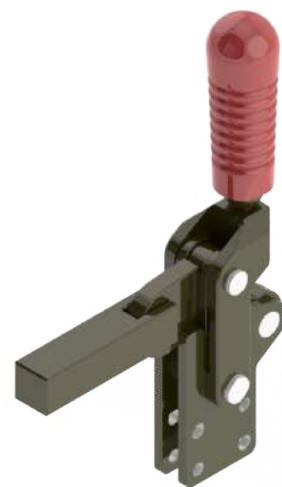

Assembled Base Straight Clamp

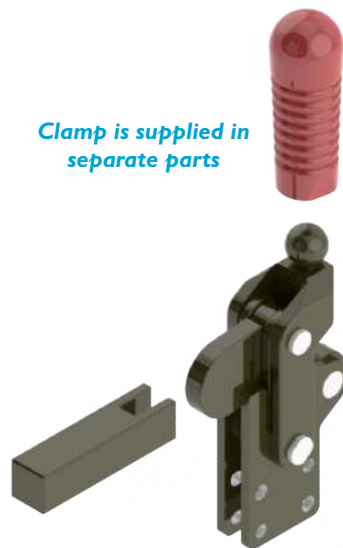

Clamp is supplied in separate parts

Anatomy of a Base Straight Clamp

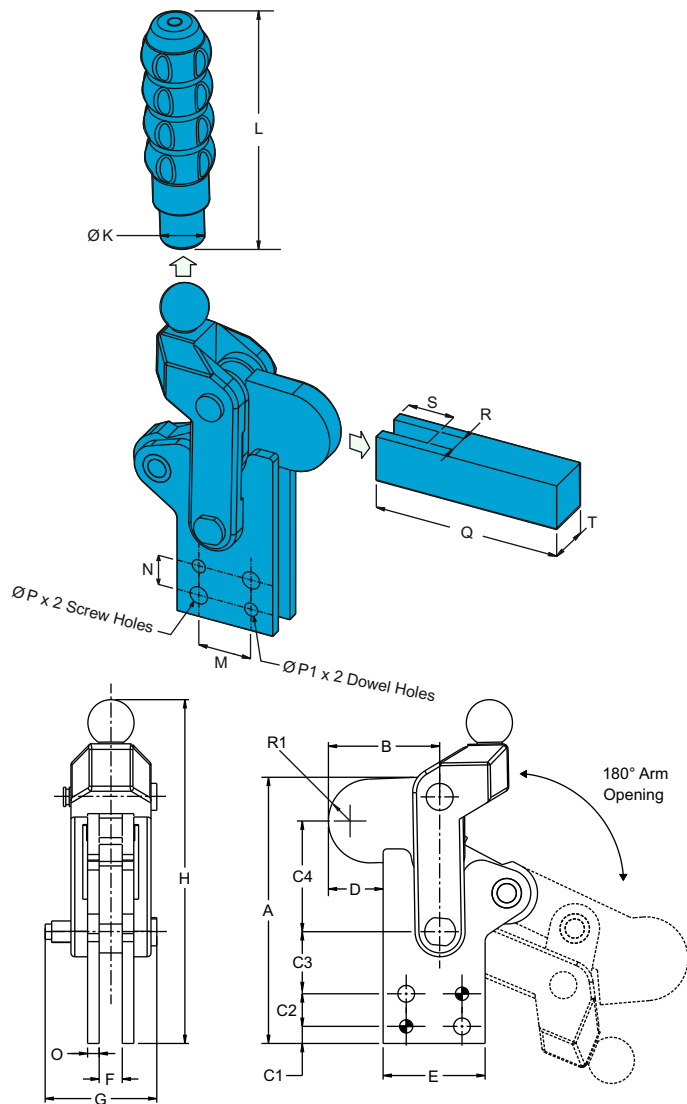

Model No.	A	B	C1	C2	C3	C4	D	E	F	G	H	K	L	M	N	O	P	P1	Q	R	R1	S	T	Holding Capacity	Wt. In Kgs
HV-BII-100 BS	70	30	8.5	12	10	28	14.5	30	6	28	98	12	50	15	12	3	5.5	5	50	6	11	13	12	200 Kgs.	0.290
HV-BII-200 BS	99	41	9	16	21	37	18	46	8	41	130	16	75	26	16	4	6.3	6	75	8	16	15	20	500 Kgs.	0.810
HV-BII-300 BS	120	50.5	12	25	20	46	24	51	10	45	158	22	90	30	25	5	9.0	8	90	10	17	21	22	700 Kgs.	1.350
HV-BII-500 BS	136	58	11	25	23	57	30	54	12	58	180	22	100	35	25	6	9.0	8	100	12	21	25	25	1200 Kgs.	2.150
HV-BII-1000 BS	177	77	15	30	30	75	42	66	15	60	217	22	125	35	30	6	10.5	10	125	15	27	32	30	2500 Kgs.	3.400

Automotive Clamps

Model No: HV - BII - 300 - TRIG

Arm: Stub nose for welded extensions.
 Base: Swivel for welding in the desired position.
 Nominal Holding Force: 700 Kgs.
 Weight: 1.400 Kgs

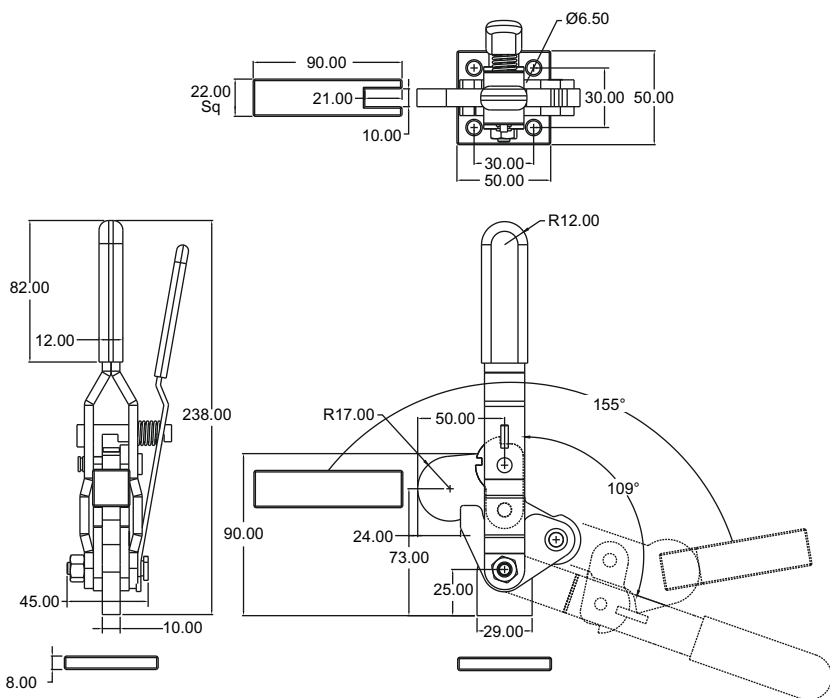

Model No.HV - BII - 500 - TRIG

Model No: HV - BII - 500 - TRIG

Arm: Stub nose for welded extensions.
 Base: Swivel for welding in the desired position.
 Nominal Holding Force: 1200 Kgs.
 Weight: 2.500 Kgs

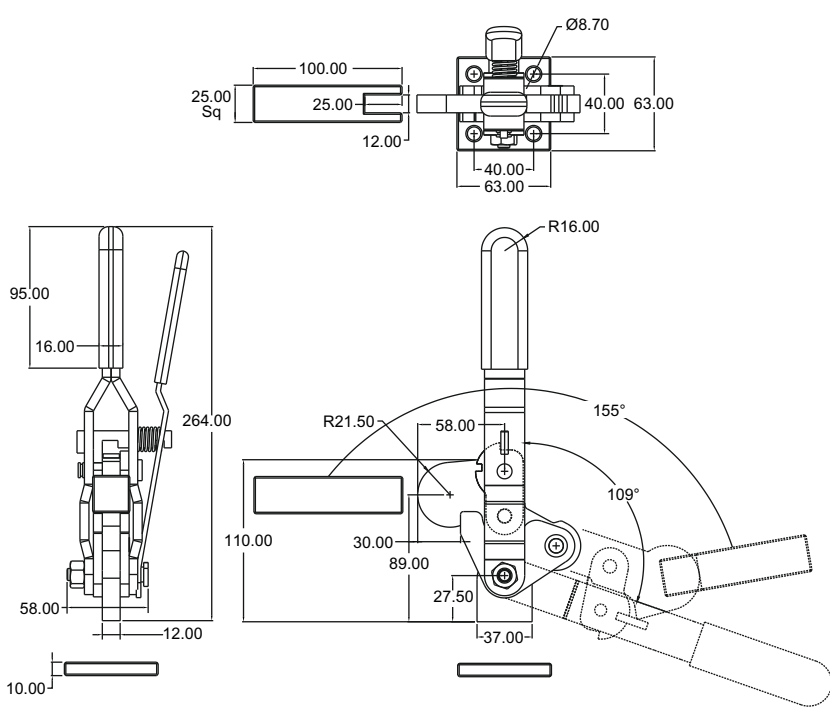

Assembled Swivel Base Clamp

Clamp is supplied in separate parts



Anatomy of Swivel Base Clamp

Model No: HV - BII - 300 BS - TRIG

Arm: Stub nose for welded extensions.
 Base: Straight
 Nominal Holding Force: 700 Kgs.
 Weight: 1.00 Kgs

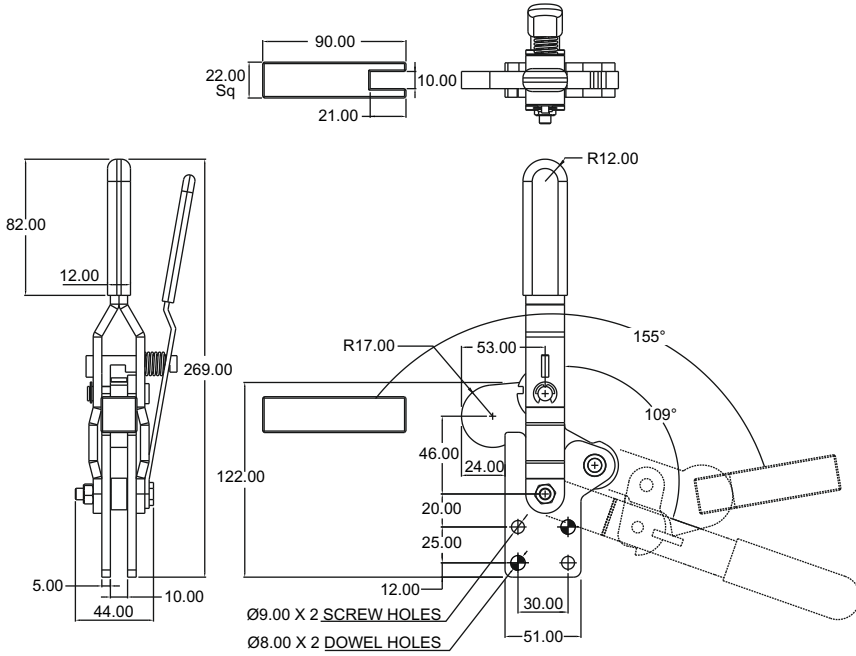

Model No. HV - BII - 500 BS - TRIG

Model No: HV - BII - 500 BS - TRIG

Arm: Stub nose for welded extensions.
 Base: Straight
 Nominal Holding Force: 1200 Kgs.
 Weight: 2.300 Kgs

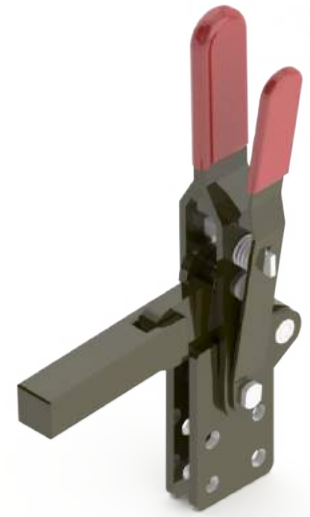
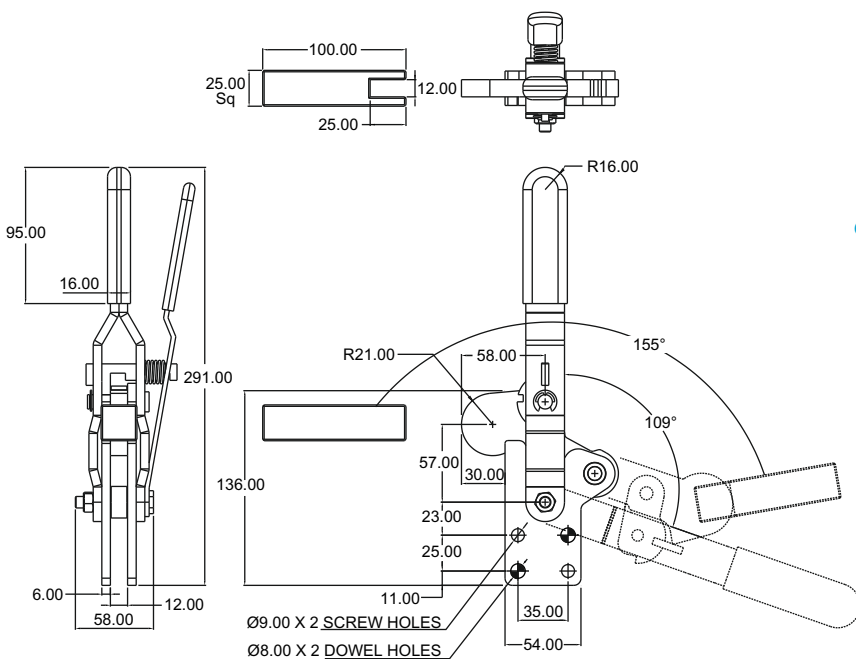

Assembled Base Straight Clamp

Clamp is supplied in separate parts

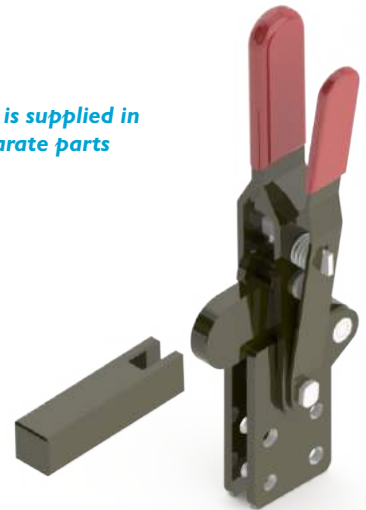

Anatomy of a Base Straight Clamp

Automotive Clamps

Model No: HV - 700 - S

Arm: Stub nose for welded extensions.
 Base: Swivel for welding in the desired position.
 Nominal Holding Force: 700 Kgs.
 Weight: 0.700 Kg
 See "Accessories" for other items.

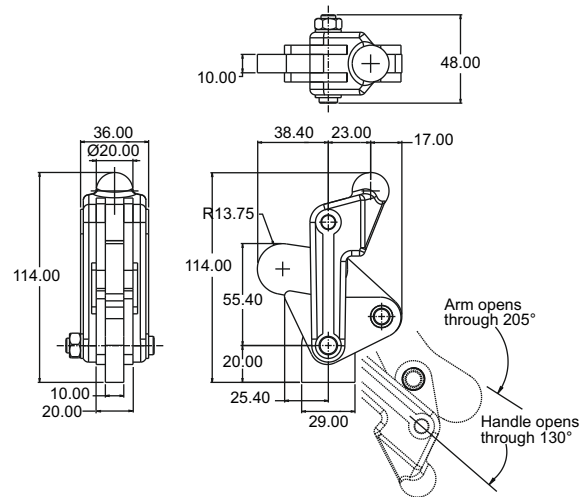

Model No: HV - 700 - T

Arm: Stub nose for welded extensions.
 Base: Straight.
 Nominal Holding Force: 700 Kgs.
 Weight: 0.800 Kgs.
 See "Accessories" for other items.

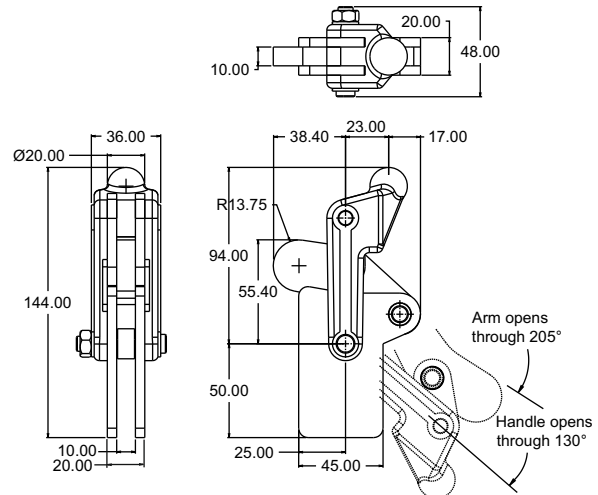

Model No: HV - 700 - 1A

Arm: Solid Arm with weldable bush.
 Base: Straight
 Nominal Holding Force: 700 Kgs.
 Weight: 1.100 Kgs.

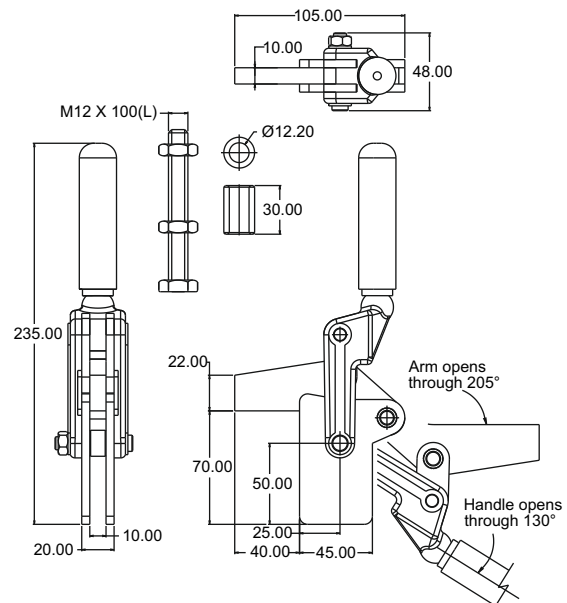

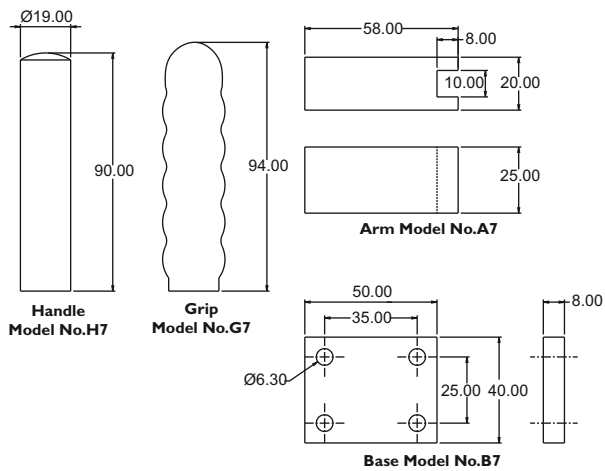

Accessories for HV - 700

Model H7 Handle: For welding at the desired angle.
 Model G7 Grip: To fit H7 handle.
 Model A7 Arm: Clamping Arm.
 Model B7 Base: For bolt mounting



Model No: HV - 1200 - S

Arm: Stub nose for welded extensions.
 Base: Swivel for welding in the desired position.
 Nominal Holding Force: 1200 Kgs.
 Weight: 1.300 Kg
 See "Accessories" for other items.

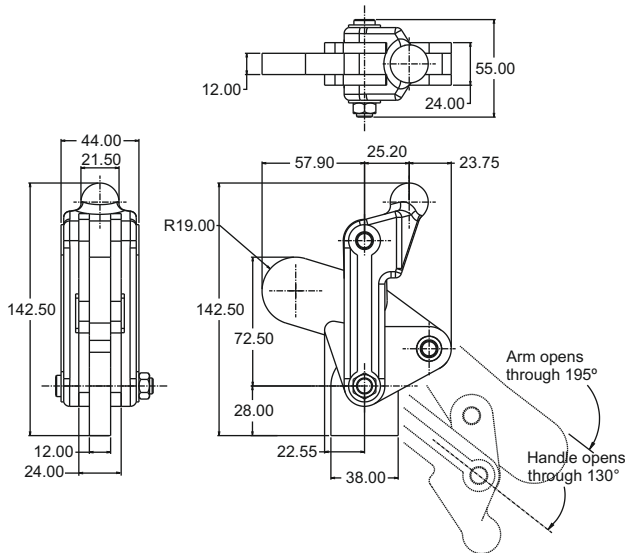

Model No: HV - 1200 - T

Arm: Stub nose for welded extensions.
 Base: Straight.
 Nominal Holding Force: 1200 Kgs.
 Weight: 1.450 Kgs.
 See "Accessories" for other items.

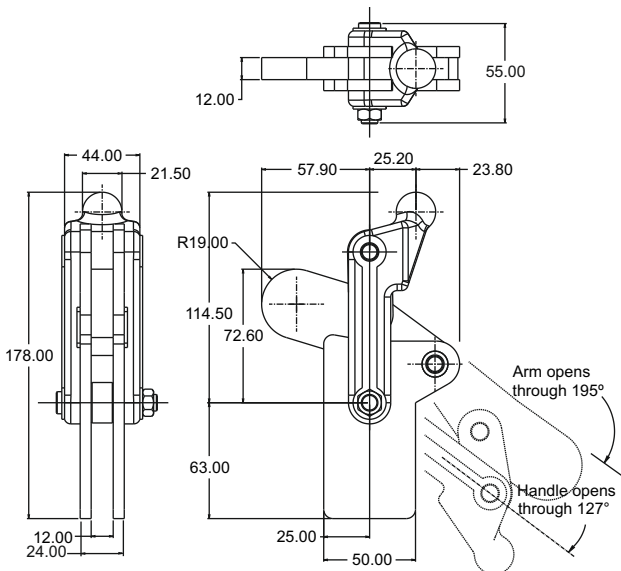

Automotive Clamps

Model No: HV - 1200 - 1A

Arm: Solid Arm with weldable bush.
 Base: Straight
 Nominal Holding Force: 1200 Kgs.
 Weight: 1.800 Kgs.

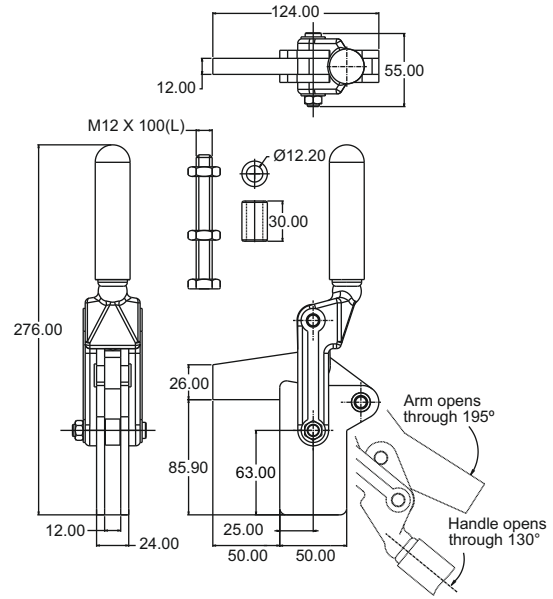

Accessories for HV - 1200

Model H12 Handle: For welding at the desired angle.
 Model G12 Grip: To fit H7 handle.
 Model A12 Arm: Clamping Arm.
 Model B12 Base: For bolt mounting

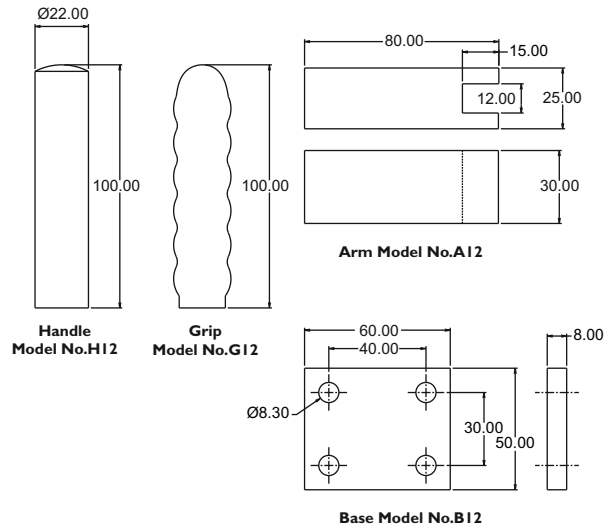

Model No: HV - 2400 - S

Arm: Stub nose for welded extensions.
 Base: Swivel for welding in the desired position.
 Nominal Holding Force: 2400 Kgs.
 Weight: 2.900 Kg
 See "Accessories" for other items.

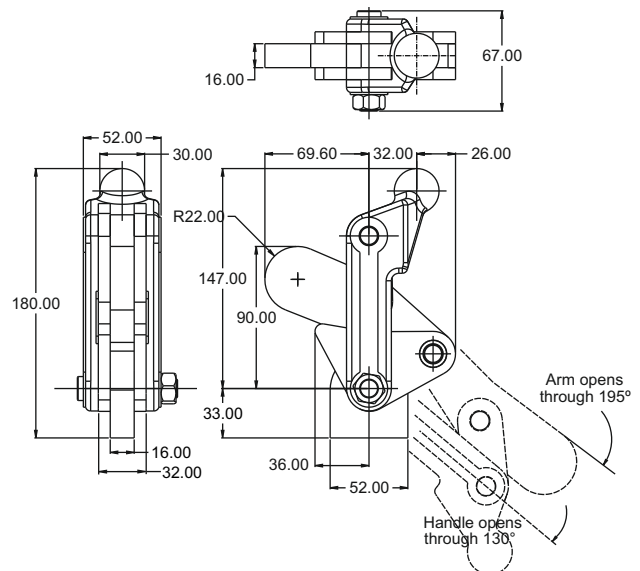

Model No: HV - 2400 - T

Arm: Stub nose for welded extensions.
 Base: Straight.
 Nominal Holding Force: 2400 Kgs.
 Weight: 3.200 Kgs.
 See "Accessories" for other items.

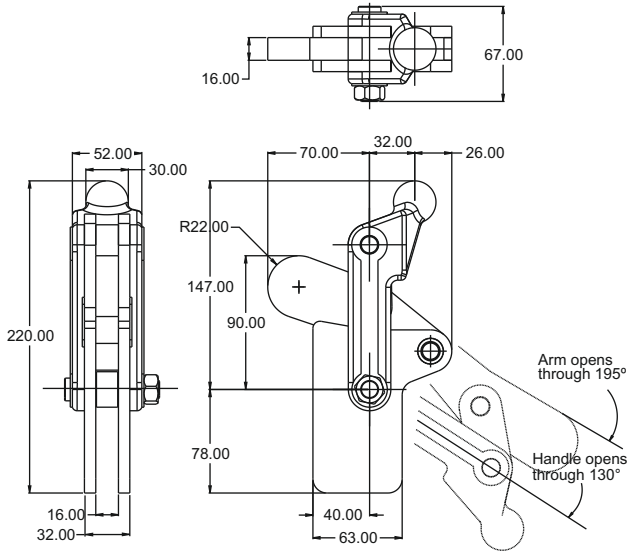

Model No: HV - 2400 - IA

Arm: Solid Arm with weldable bush.
 Base: Straight
 Nominal Holding Force: 2400 Kgs.
 Weight: 3.7500 Kgs.

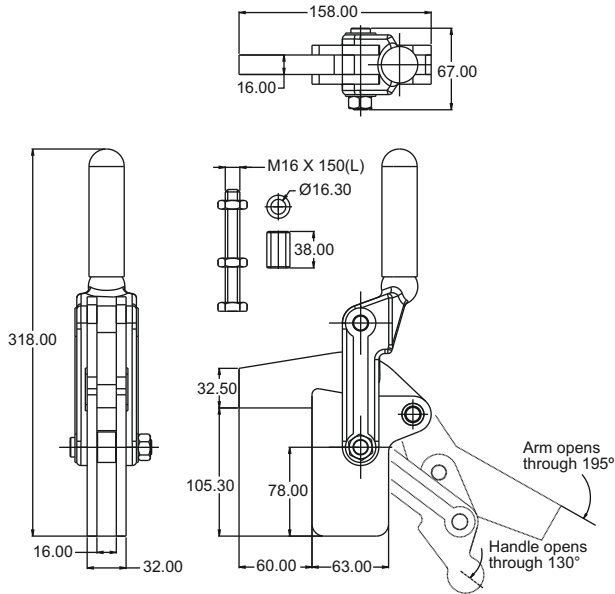

Accessories for HV - 2400

Model H24 Handle: For welding at the desired angle.
 Model G24 Grip: To fit H7 handle.
 Model A24 Arm: Clamping Arm.
 Model B24 Base: For bolt mounting

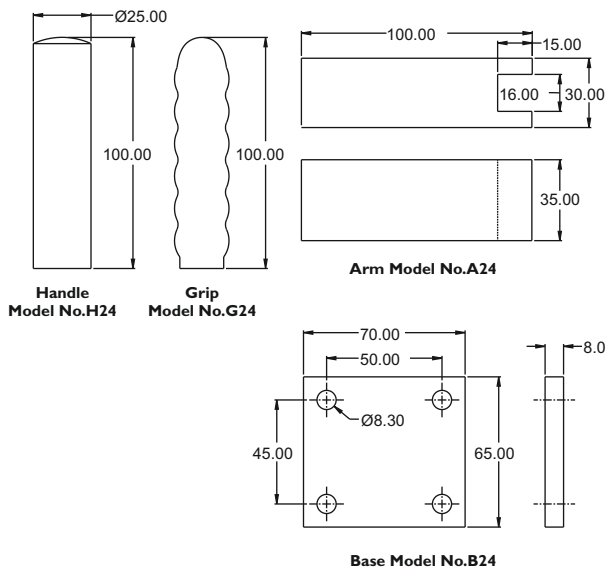

Automotive Clamps Horizontal Arm

Model No: HV - 700 - H

Arm: Horizontal Clamping Arm
Base: Straight with Dowel & Bolt Holes
Nominal Holding Force: 700 Kgs.
Weight: 1.200 Kgs.

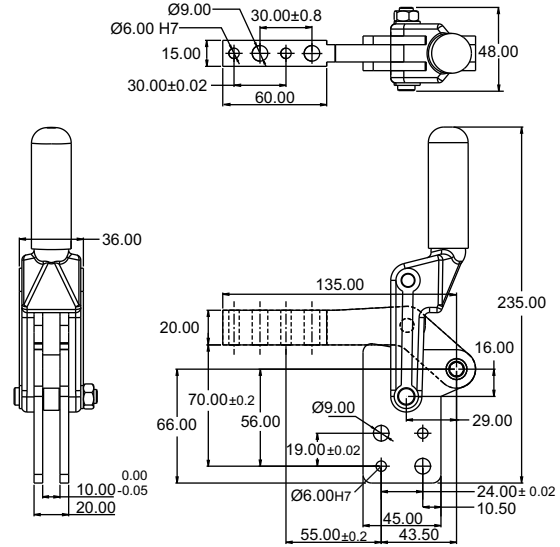

Model No: HV - 1200 - H - TM - TU

Arm: Horizontal Clamping Arm
Base: Straight with Dowel & Bolt Holes
Nominal Holding Force: 1200 Kgs.
Weight: 2.100 Kgs.

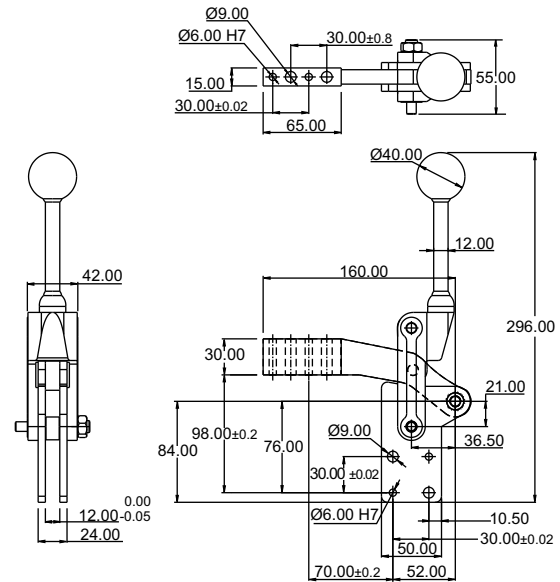

Model No: HV - 2400 - H - TM - TU

Arm: Horizontal Clamping Arm
Base: Straight with Dowel & Bolt Holes
Nominal Holding Force: 2400 Kgs.
Weight: 3.100 Kgs.

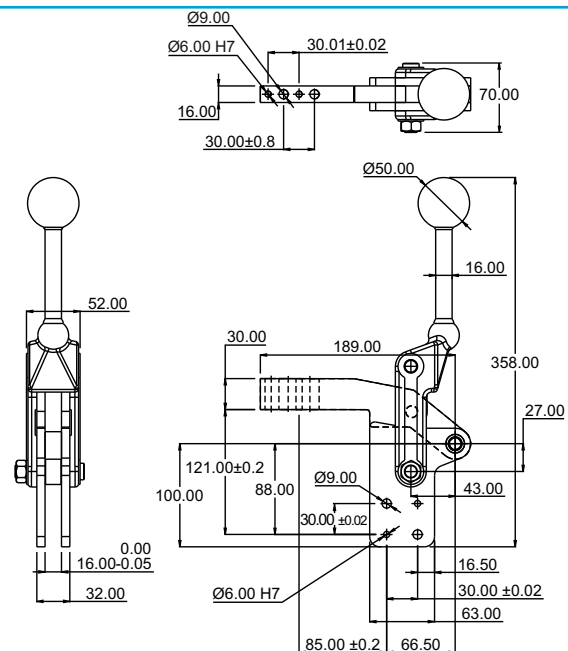

Automotive Clamps Vertical Arm

Model No: HV - 700 - V

Arm: Vertical Clamping Arm
 Base: Straight with Dowel & Bolt Holes
 Nominal Holding Force: 700 Kgs.
 Weight: 1.200 Kgs.

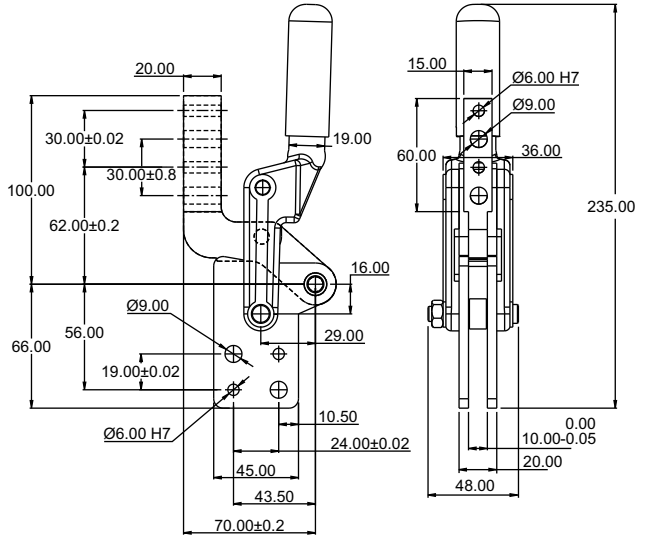

Model No: HV - 1200 - V - TM - TU

Arm: Vertical Clamping Arm
 Base: Straight with Dowel & Bolt Holes
 Nominal Holding Force: 1200 Kgs.
 Weight: 2.100 Kgs.

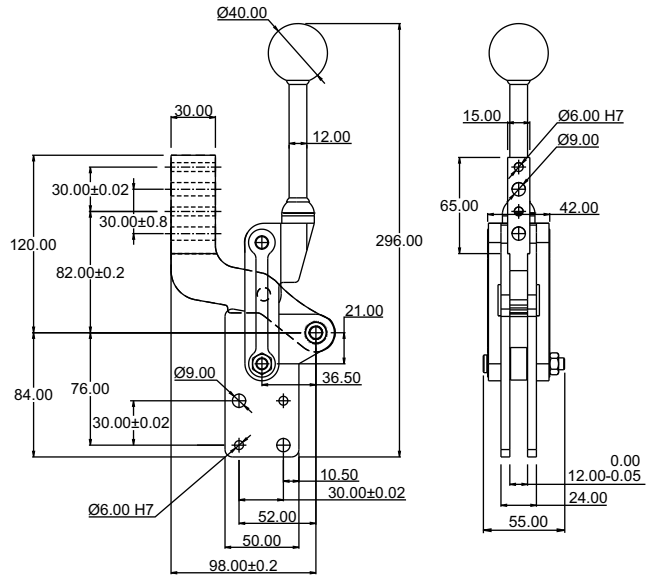

Model No: HV - 2400 - V - TM - TU

Arm: Vertical Clamping Arm
 Base: Straight with Dowel & Bolt Holes
 Nominal Holding Force: 2400 Kgs.
 Weight: 3.100 Kgs.

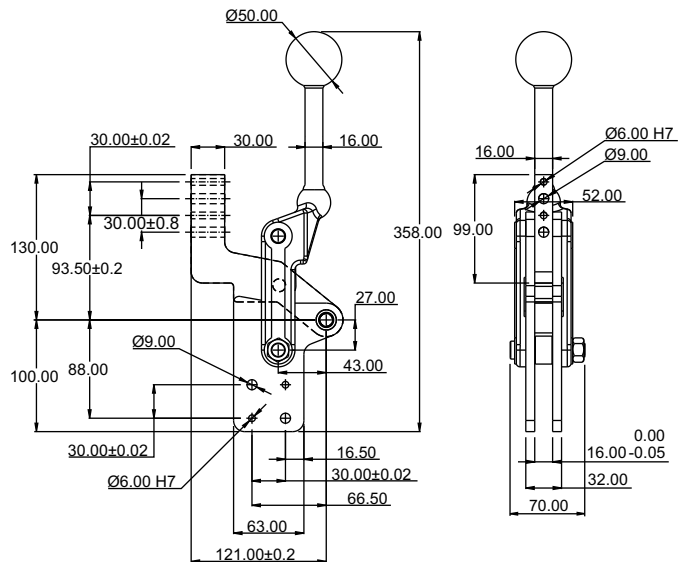

Automotive Clamps Horizontal Arm - TP

Model No: HV - 700 - TP

Arm: Horizontal Clamping Arm
Base: Straight with Dowel & Bolt Holes
Nominal Holding Force: 700 Kgs.
Weight: 1.200 Kgs.

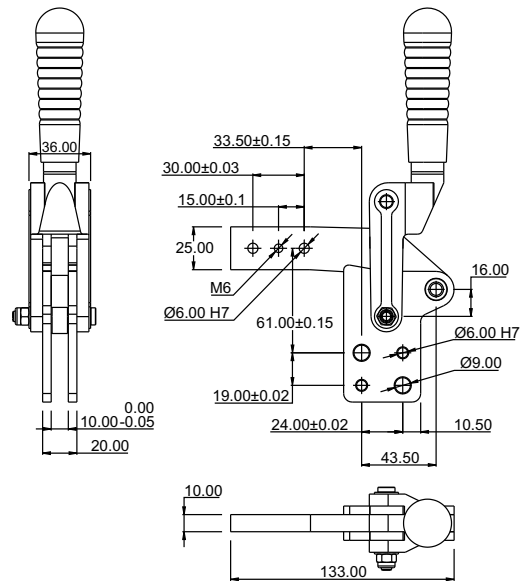

Model No: HV - 1200 - TP

Arm: Horizontal Clamping Arm
Base: Straight with Dowel & Bolt Holes
Nominal Holding Force: 1200 Kgs.
Weight: 2.100 Kgs.

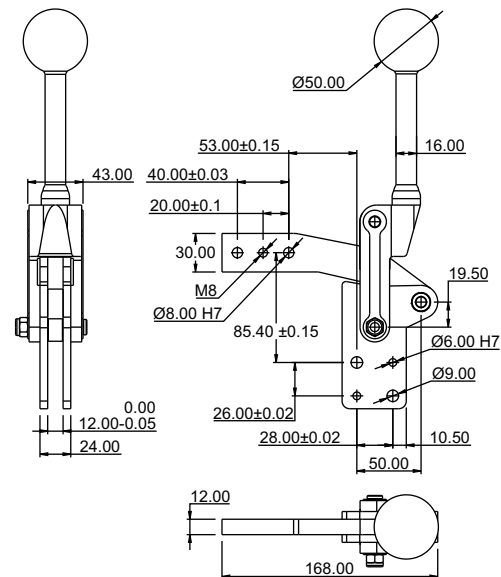

Model No: HV - 2400 - TP

Arm: Horizontal Clamping Arm
Base: Straight with Dowel & Bolt Holes
Nominal Holding Force: 2400 Kgs.
Weight: 3.100 Kgs.

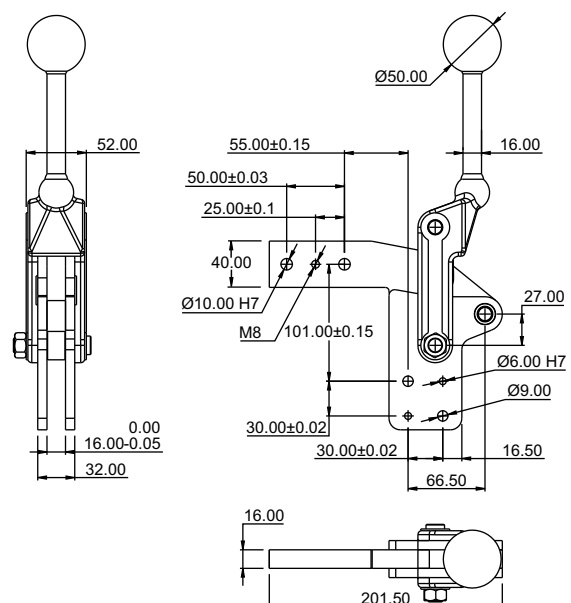

Clamping Force / Holding Capacity: Arm Lengths

The construction of the Automotive Clamps enables mounting of Clamping Arms/Adapters onto the clamp. There are limitations to the length and weight of the arm that can be mounted on the clamp. Longer the arm lesser the holding/clamping capacity. Refer the data below to for different capacities at different lengths.

Model No.	Maximum Permissible Arm Length	Maximum Permissible Weight of Clamping Arm
HV - 700 - H	200 mm	3 Kgs
HV - 1200 - H - TM -TU	300 mm	5 Kgs
HV - 2400 - H - TM -TU	400 mm	7 Kgs

Model No: HV - 700 - H

Model No: HV - 1200 - H - TM -TU

Model No: HV - 2400 - H - TM -TU

Automotive Clamps

Clamping Force / Holding Capacity: Arm Lengths

The construction of the Automotive Clamps enables mounting of Clamping Arms/Adapters onto the clamp. There are limitations to the length and weight of the arm that can be mounted on the clamp. Longer the arm lesser the holding/clamping capacity. Refer the data below to for different capacities at different lengths.

Model No.	Maximum Permissible Arm Length	Maximum Permissible Weight of Clamping Arm
HV - 700 - V	200 mm	3 Kgs
HV - 1200 - V - TM -TU	300 mm	5 Kgs
HV - 2400 - V - TM -TU	400 mm	7 Kgs

Model No: HV - 700 - V

Model No: HV - 1200 - V - TM -TU

Model No: HV - 2400 - V - TM -TU

Modular Clamps - LH

Compact heavy duty modular clamps with a very low clamping arm height. The unique feature of these clamps is the arm/handle configurations can be change into 8 different types of clamps as shown in the below table

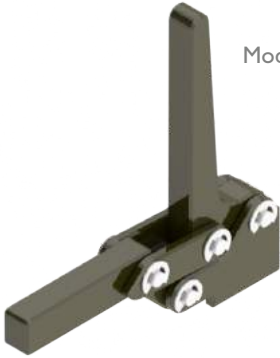

Model No. HV - 25 - LH



Anatomy of a Modular Clamp
Mounting Plate will be supplied separately

8 Different Configuration of Modular Clamps

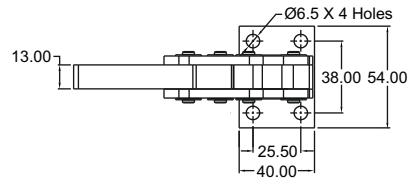
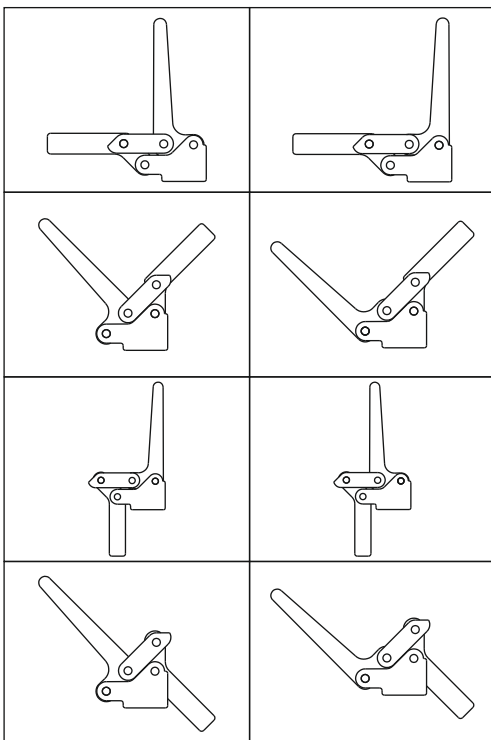

Model No: HV - 22 - LH

Nominal Holding Force: 700 Kgs.
Weight: 0.900 Kgs.
Arm Opens: 83°
Handle Opens:83°

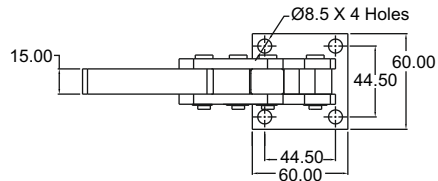
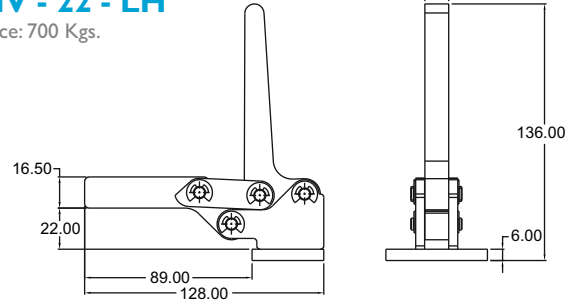

Model No: HV - 25 - LH

Nominal Holding Force: 1200 Kgs.
Weight: 1.200 Kgs.
Arm Opens: 83°
Handle Opens:83°

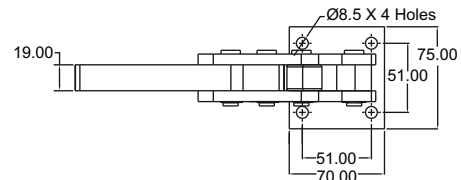
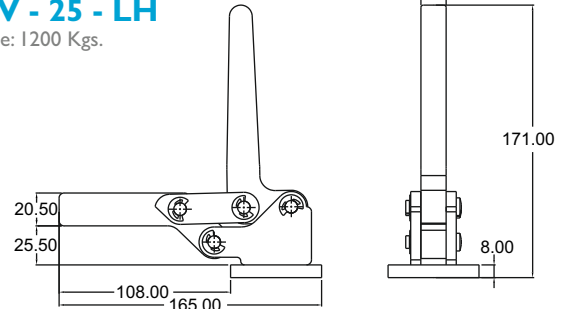

Model No: HV - 33 - LH

Nominal Holding Force: 2,200 Kgs.
Weight: 2.300 Kgs.
Arm Opens: 83°
Handle Opens:83°

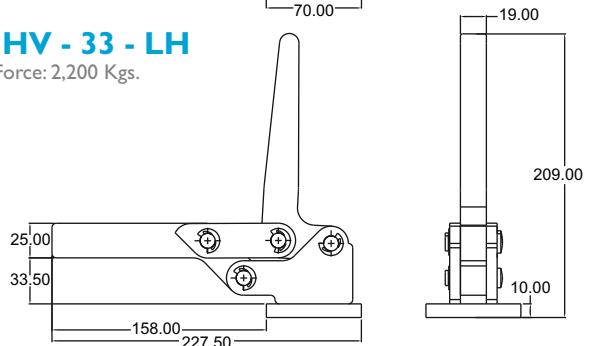

Automotive Clamps

Modular Clamps - HA

Compact heavy duty modular clamps with a very low clamping arm height. The unique feature of these clamps is the arm/handle configurations can be change into 8 different types of clamps as shown in the below table

Model No: HV - 44 - HA

Nominal Holding Force: 700 Kgs.
Weight: 0.900 Kgs.
Arm Opens: 83°
Handle Opens: 83°



Model No. HV - 44 - HA

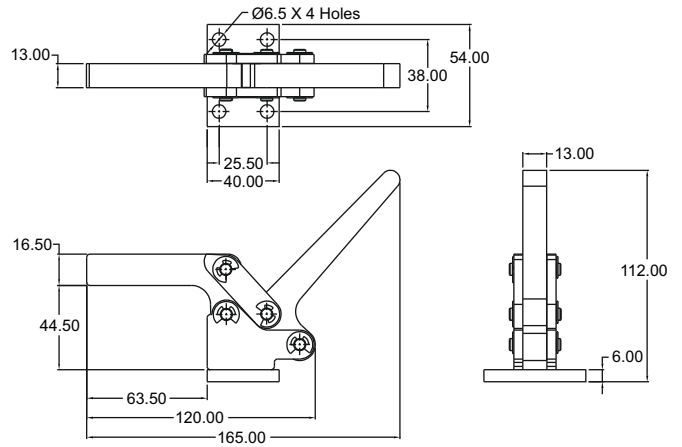

Anatomy of a Modular Clamp
Mounting Plate will be supplied separately

Model No: HV - 65 - HA

Nominal Holding Force: 1200 Kgs.
Weight: 1.200 Kgs.
Arm Opens: 83°
Handle Opens: 83°

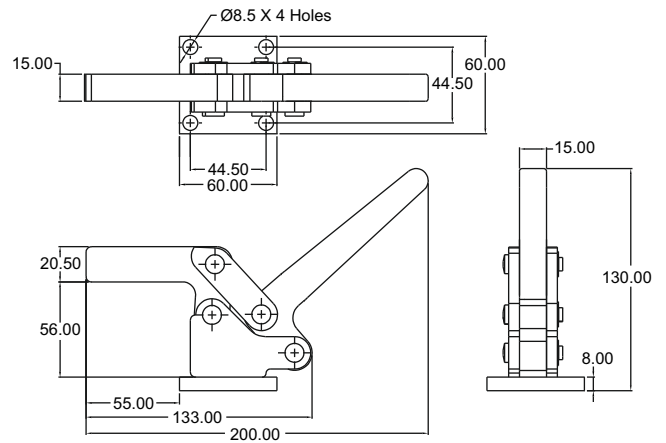

8 Different Configuration of Modular Clamps

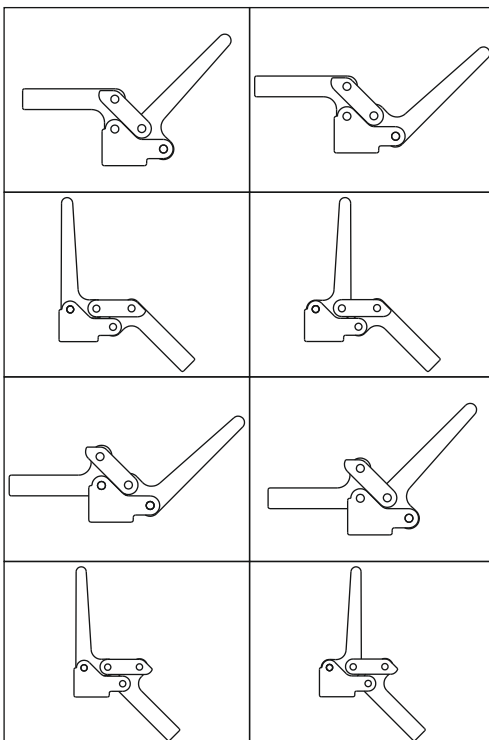

Model No: HV - 70 - HA

Nominal Holding Force: 2,200 Kgs.
Weight: 2.300 Kgs.
Arm Opens: 83°
Handle Opens: 83°

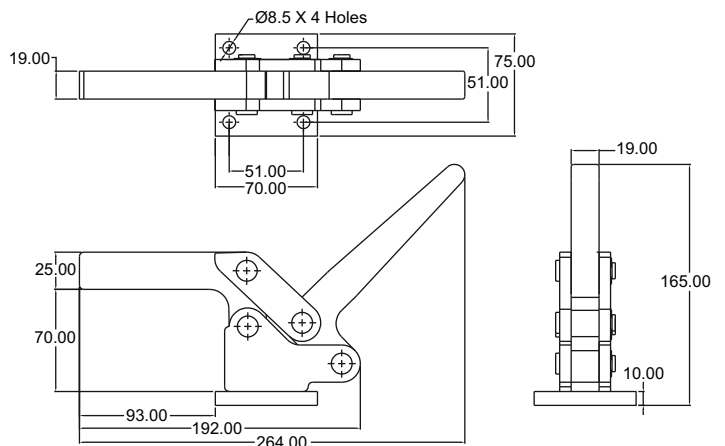

The all new international equivalent range of toggle clamps from Steel-Smith. Now all the leading international toggle clamps have their equivalents in this range. What's more, these quality clamps come with hardened bushes for enhanced life, several safety features and slicker finish.



'Safety Cover' on the clamp link

This feature protects the user's finger from accidentally entering the clamp linking and getting injured during clamping operations.



Hardened Bushes

Hardened Bushes increase the life of the clamp, thereby multiplying the productivity.

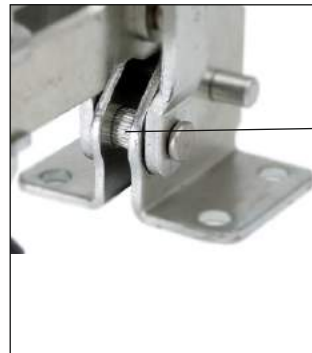

Hardened Bushes



New improved design includes increased distance between the handle and the clamping arm. This ensures maximum safety during the clamp's fully open position.

Extra distance for safety

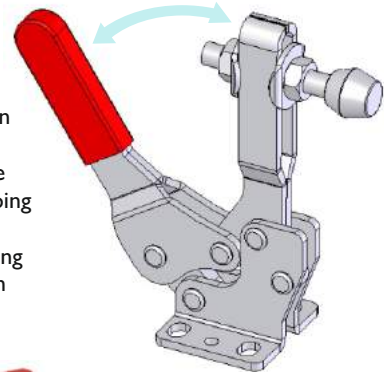

Kindly refer the cross-reference list on Page No.78 & 79 to order the Steel-Smith equivalent toggle clamp that meets your requirement.



Additional Locking Mechanism

The additional locking Mechanism ensures that the clamp remains locked in any condition. In order to unclamp, the mechanism must be first released.

Vertical Hold Down Action

Vertical Hold Down Action VTC - 201 Series



Model No.VTC-201-U



Model No.VTC-201-UB

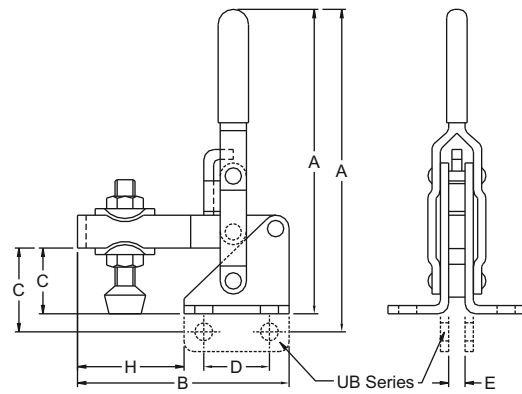
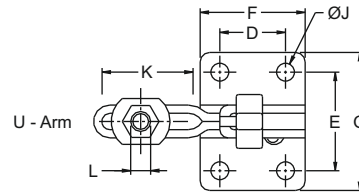

Also Available in Stainless Steel
VTC-201-U-SS
VTC-201-UB-SS

Model No.	Arm Type	Base Type
VTC-201-U	Adjustable Arm	Flanged
VTC-201-UB	Adjustable Arm	Straight

Model No.	Holding Capacity	Weight Kg	Handle Moves	Bar Opens	Dimensions										
					A	B	C	D	E	F	G	H	J	K	L
VTC-201-U	50 Kgs	0.090	60°	110°	83.3	50.7	16.0	16.0	23.9	25.0	33.0	25.5	4.4	18.3	M5 Bolt
VTC-201-UB	50 Kgs	0.090	60°	110°	91.0	50.7	21.5	16.0	4.0	25.0	—	25.5	4.4	18.3	M5 Bolt

Horizontal Hold Down Action

Arm: Adjustable Arm
 Base: Flanged Mounting
 Holding Capacity: 30 Kgs.
 Weight: 0.030 Kgs.
 Handle Moves: 60°
 Bar Opens: 85°

Also Available in Stainless Steel
H - 205 - U - SS



Model No. H - 205 U

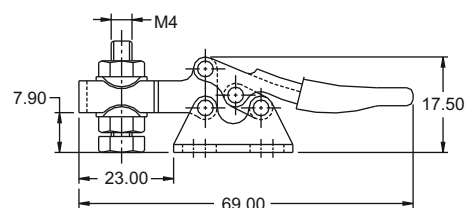
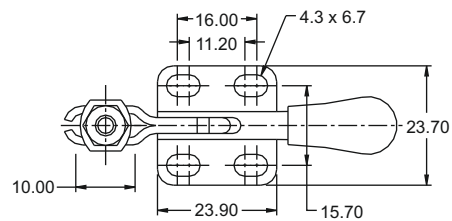

**Vertical Hold Down Action
VTC - 202 Series**



Model No. VTC-202-UB



Model No. VTC-202-U

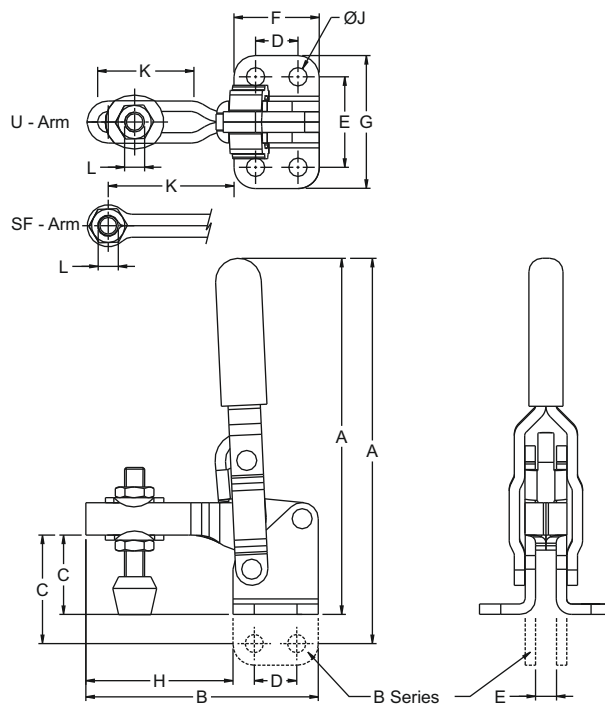

Also Available
in Stainless Steel
VTC-202-U-SS
VTC-202-UB-SS

Model No.	Arm Type	Base Type
VTC-202-SF	Spindle Fixed	Flanged
VTC-202-SFB	Spindle Fixed	Straight
VTC-202-U	Adjustable Arm	Flanged
VTC-202-UB	Adjustable Arm	Straight
VTC-202-UL	Adjustable Arm	Flanged

Model No.	Holding Capacity	Weight Kg	Handle Moves	Bar Opens	Dimensions										
					A	B	C	D	E	F	G	H	J	K	L
VTC-202-SF	100 Kgs	0.150	64°	104°	106.0	62.6	24.0	12.7	26.9	25.5	39.3	33.3	5.5	26.5	M6 Bolt
VTC-202-SFB	100 Kgs	0.150	64°	104°	115.0	62.6	28.3	12.7	6.0	25.5	-	33.3	5.5	26.5	M6 Bolt
VTC-202-U	100 Kgs	0.160	64°	104°	106.0	75.2	23.9	12.7	26.9	25.5	39.3	45.8	5.5	25.4	M6 Bolt
VTC-202-UB	100 Kgs	0.160	64°	104°	115.0	75.2	28.3	12.7	6.0	25.5	-	45.8	5.5	25.4	M6 Bolt
VTC-202-UL	100 Kgs	0.160	64°	104°	106.0	86.0	23.9	12.7	26.9	25.5	39.3	60.5	5.5	40.0	M6 Bolt

Vertical Hold Down Action

Vertical Hold Down Action VTC - 207 Series



Model No.VTC-207-U



Model No.VTC-207-UB



Model No.VTC-207-S



Model No.VTC-207-SB

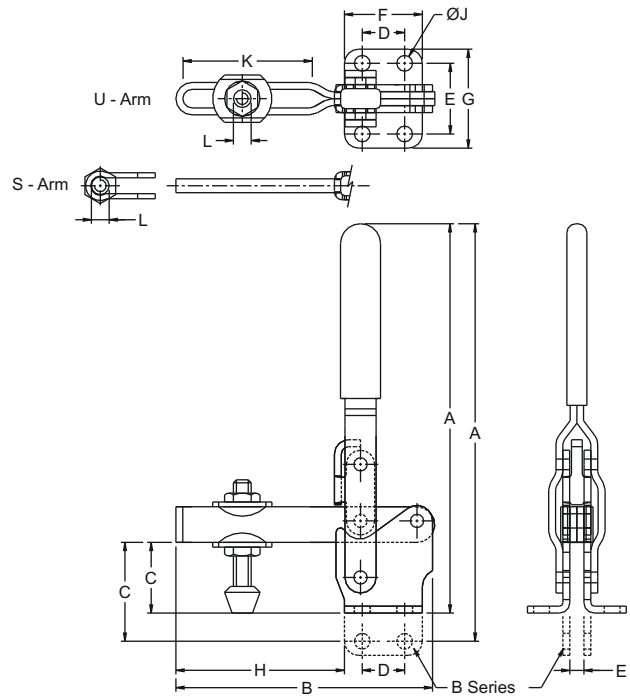

Also Available
in Stainless Steel
VTC-207-U-SS
VTC-207-UB-SS

Model No.	Arm Type	Base Type
VTC-207-L	Solid Arm	Flanged
VTC-207-LB	Solid Arm	Straight
VTC-207-S	Solid Arm	Flanged
VTC-207-SB	Solid Arm	Straight
VTC-207-U	Adjustable Arm	Flanged
VTC-207-UB	Adjustable Arm	Straight
VTC-207-UL	Adjustable Arm	Flanged
VTC-207-ULB	Adjustable Arm	Straight

Model No.	Holding Capacity	Weight Kg	Handle Moves	Bar Opens	Dimensions										
					A	B	C	D	E	F	G	H	J	K	L
VTC-207-L	200 Kgs	0.340	62°	115°	174.0	130.0	31.0	19.1	31.8	35.1	44.6	86.5	7.1	-	M8 Bolt
VTC-207-LB	200 Kgs	0.340	62°	115°	189.0	130.0	40.0	19.1	6.0	35.1	-	86.5	7.1	-	M8 Bolt
VTC-207-S	215 Kgs	0.315	62°	115°	174.0	98.0	31.0	19.1	31.8	35.1	44.6	54.5	7.1	-	M8 Bolt
VTC-207-SB	215 Kgs	0.300	62°	115°	189.0	98.0	40.0	19.1	6.0	35.1	-	54.5	7.1	-	M8 Bolt
VTC-207-U	175 Kgs	0.300	62°	115°	174.0	100.0	31.0	19.1	31.8	35.1	44.6	57.5	7.1	32.0	M8 Bolt
VTC-207-UB	175 Kgs	0.300	62°	115°	189.0	100.0	40.0	19.1	6.0	35.1	-	57.5	7.1	32.0	M8 Bolt
VTC-207-UL	150 Kgs	0.340	62°	115°	174.0	146.5	31.0	19.1	31.8	35.1	44.6	104.0	7.1	78.5	M8 Bolt
VTC-207-ULB	150 Kgs	0.340	62°	115°	189.0	146.5	40.0	19.1	6.0	35.1	-	104.0	7.1	78.5	M8 Bolt

**Vertical Hold Down Action
VTC - 210 Series**



Model No.VTC-210-U



Model No.VTC-210-UB



Model No.VTC-210-S



Model No.VTC-210-SB

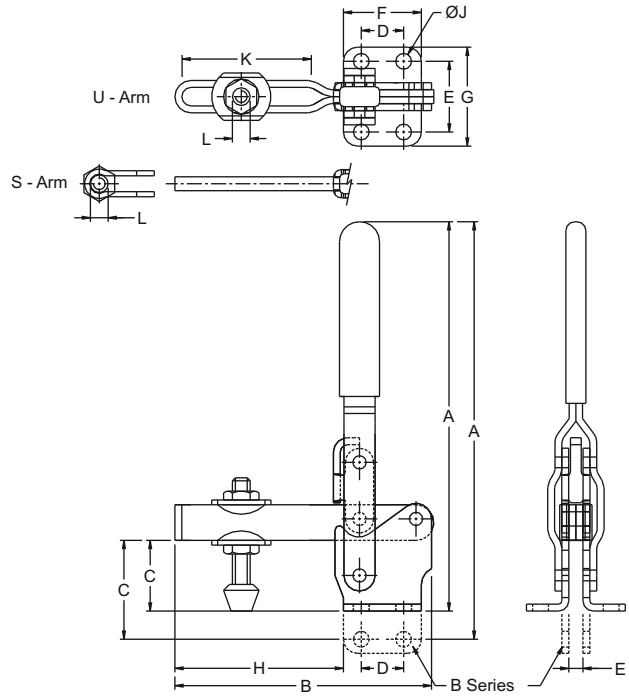

Also Available
in Stainless Steel
VTC-210-U-SS
VTC-210-UB-SS

Model No.	Arm Type	Base Type
VTC-210-S	Solid Arm	Flanged
VTC-210-SB	Solid Arm	Straight
VTC-210-U	Adjustable Arm	Flanged
VTC-210-UB	Adjustable Arm	Straight

Model No.	Holding Capacity	Weight Kg	Handle Moves	Bar Opens	Dimensions										
					A	B	C	D	E	F	G	H	J	K	L
VTC-210-S	350 Kgs	0.590	58°	106°	195.0	144.0	42.0	31.8	45.2	48.6	64.4	91.0	8.3	-	M10 Bolt
VTC-210-SB	350 Kgs	0.590	58°	106°	219.0	144.0	56.5	31.8	8.0	48.6	-	90.0	8.3	-	M10 Bolt
VTC-210-U	275 Kgs	0.590	58°	106°	195.0	144.0	42.0	31.8	45.2	48.6	64.4	91.0	8.3	60.0	M10 Bolt
VTC-210-UB	275 Kgs	0.590	58°	106°	219.0	144.0	56.5	31.8	8.0	48.6	-	90.0	8.3	60.0	M10 Bolt

Vertical Hold Down Action

Vertical Hold Down Action VTC - 247 & VTC - 267 Series



Model No.VTC-247-U



Model No.VTC-247-S



Model No.VTC-267-U



Model No.VTC-247-SB

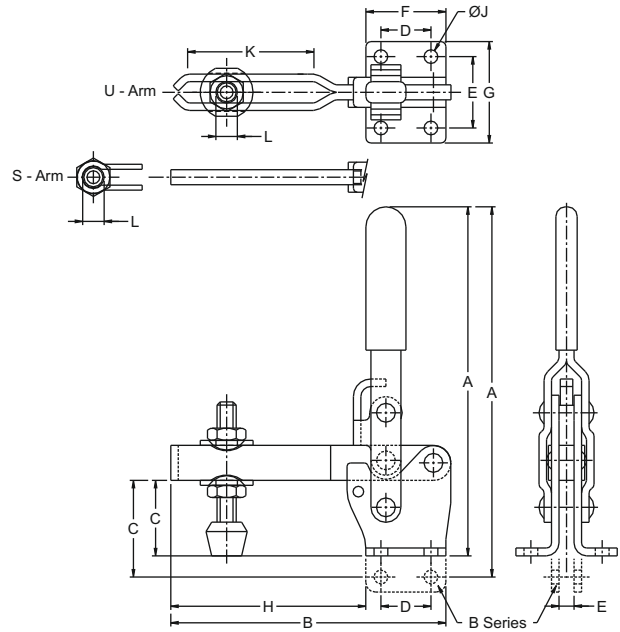

Model No.	Arm Type	Base Type
VTC-247-S	Solid Arm	Flanged
VTC-247-SB	Solid Arm	Straight
VTC-247-U	Adjustable Arm	Flanged
VTC-247-UB	Adjustable Arm	Straight
VTC-267-S	Solid Arm	Flanged
VTC-267-U	Adjustable Arm	Flanged

Model No.	Holding Capacity	Weight Kg	Handle Moves	Bar Opens	Dimensions										
					A	B	C	D	E	F	G	H	J	K	L
VTC-247-S	450 Kgs	1.000	75°	136°	220.0	177.0	50.8	31.8	45.0	50.8	64.3	124.0	8.6	--	M12 Bolt
VTC-247-SB	450 Kgs	1.000	75°	136°	245.0	177.0	61.0	31.8	10.0	50.8	--	124.0	8.6	--	M12 Bolt
VTC-247-U	450 Kgs	1.100	75°	136°	220.0	177.0	50.8	31.8	45.0	50.8	64.3	124.0	8.6	71.4	M12 Bolt
VTC-247-UB	450 Kgs	1.100	75°	136°	245.0	177.0	61.0	31.8	10.0	50.8	--	124.0	8.6	71.4	M12 Bolt
VTC-267-S	550 Kgs	2.000	70°	140°	328.0	230.0	82.0	50.8	69.9	76.2	95.0	156.8	12.5	--	M16 Bolt
VTC-267-U	550 Kgs	2.200	70°	140°	328.0	230.0	82.0	50.8	69.9	76.2	95.0	156.8	12.5	108.0	M16 Bolt

**Horizontal Hold Down Action
H - 206 Series**



Model No. H-206-U



Model No. H-206-HU

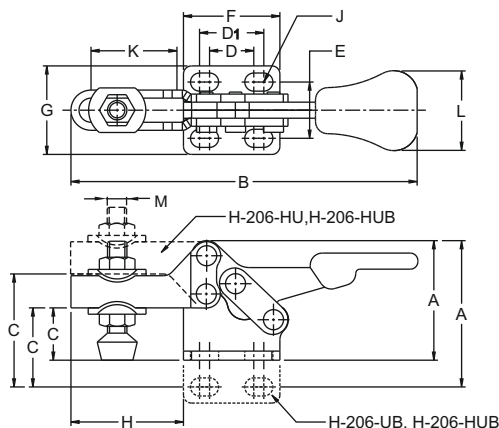

Model No.	Arm Type	Base Type
H-206-U	Adjustable Arm	Flanged
H-206-UB	Adjustable Arm	Straight
H-206-HU	High Adjustable Arm	Flanged
H-206-HUB	High Adjustable Arm	Straight

Model No.	Holding Capacity	Weight Kg	Handle Moves	Bar Opens	Dimensions												
					A	B	C	D	D1	E	F	G	H	J/Slot	K	L	M
H-206-U	50 Kgs	0.040	90°	90°	29.0	86.0	12.5	11.1	15.8	15.9	24.2	24.3	29.0	4.3 x 6.8	12	20.0	M5 Bolt
H-206-UB	50 Kgs	0.040	90°	90°	33.5	86.0	17.0	11.1	15.8	--	24.2	--	29.0	4.3 x 6.8	12	20.0	M5 Bolt
H-206-HU	50 Kgs	0.040	90°	90°	29.0	86.0	20.5	11.1	15.8	15.9	24.2	24.3	29.0	4.3 x 6.8	12	20.0	M5 Bolt
H-206-HUB	50 Kgs	0.040	90°	90°	33.5	86.0	24.9	11.1	15.8	--	24.2	--	29.0	4.3 x 6.8	12	20.0	M5 Bolt

**Horizontal Hold Down Action
H - 305, 307, 309 Series**

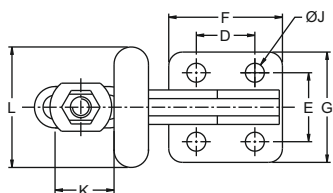

Model No. H-305-U

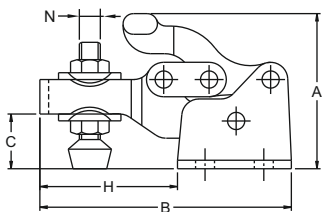

Model No. H-307-U

Also Available in Stainless Steel
H-305-U-SS
H-307-U-SS
H-309-U-SS

Model No.	Holding Capacity	Weight Kg	Handle Moves	Bar Opens	Dimensions											
					A	B	C	D	E	F	G	H	J	K	L	N
H-305-U	50 Kgs	0.070	175°	92°	38.0	59.0	13.5	13.5	16.0	26.1	25.4	30.0	4.5	8.0	32.0	M5 Bolt
H-307-U	150 Kgs	0.250	175°	92°	62.0	93.0	23.5	23.0	29.4	43.6	46.6	46.0	7.0	17.0	51.0	M8 Bolt
H-309-U	350 Kgs	0.600	160°	88°	91.2	131.8	33.3	35.1	38.1	64.0	62.7	67.6	8.4	26.9	78.0	M10 Bolt

Horizontal Hold Down Action

Horizontal Hold Down Action H - 215 Series



Model No. H-215-U

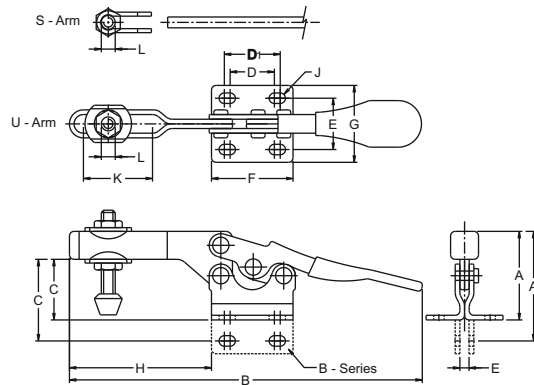

Also Available
in Stainless Steel
H-215-U-SS
H-215-UB-SS

Model No.	Arm Type	Base Type
H-215-S	Solid Arm	Flanged
H-215-SB	Solid Arm	Straight
H-215-U	Adjustable Arm	Flanged
H-215-UB	Adjustable Arm	Straight

Model No.	Holding Capacity	Weight Kg	Handle Moves	Bar Opens	Dimensions											
					A	B	C	D	D1	E	F	G	H	J/slot	K	L
H-215-S	100 Kgs	0.150	70°	90°	39.0	148.0	27.0	25.4	27.0	22.0	35.6	35.0	63.0	5x5.8	-	M6 Bolt
H-215-SB	100 Kgs	0.150	70°	90°	47.0	148.0	35.0	25.4	26.9	5.0	35.0	-	63.0	5x5.8	-	M6 Bolt
H-215-U	100 Kgs	0.150	70°	90°	39.0	148.0	27.0	25.4	27.0	22.0	35.6	35.0	63.0	5x5.8	35.0	M6 Bolt
H-215-UB	100 Kgs	0.150	70°	90°	47.0	148.0	35.0	25.4	26.9	5.0	35.0	-	63.0	5x5.8	35.0	M6 Bolt

Horizontal Hold Down Action H - 225 Series



Model No. H-225-U

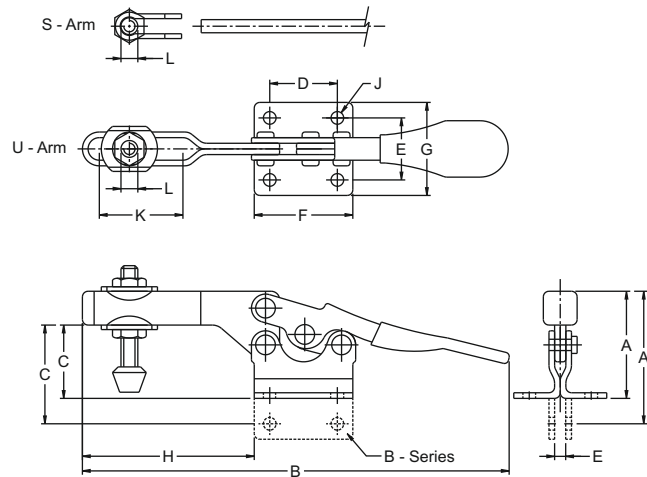

Also Available
in Stainless Steel
H-225-U-SS
H-225-UB-SS

Model No.	Arm Type	Base Type
H-225-S	Solid Arm	Flanged
H-225-SB	Solid Arm	Straight
H-225-U	Adjustable Arm	Flanged
H-225-UB	Adjustable Arm	Straight

Model No.	Holding Capacity	Weight Kg	Handle Moves	Bar Opens	Dimensions											
					A	B	C	D	E	F	G	H	J	K	L	
H-225-U	225 Kgs	0.260	70°	90°	47.0	178.0	34.0	25.4	22.4	38.1	35.0	73.5	6.8	33.0	M8 Bolt	
H-225-UB	225 Kgs	0.260	70°	90°	53.0	178.0	40.0	25.4	6	38.1	-	73.5	6.8	38.0	M8 Bolt	

**Horizontal Hold Down Action
H - 235 Series**



Model No.H-235-U

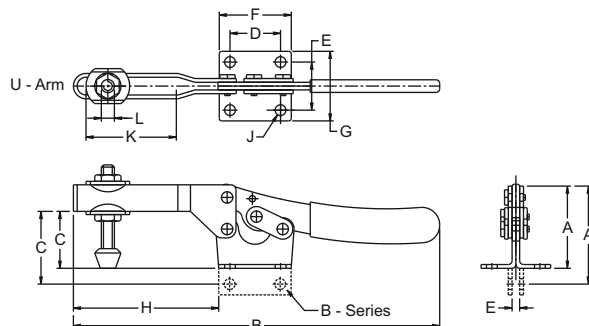

Model No.	Arm Type	Base Type
H-235-U	Adjustable Arm	Flanged
H-235-UB	Adjustable Arm	Straight

Model No.	Holding Capacity	Weight Kg	Handle Moves	Bar Opens	Dimensions										
					A	B	C	D	E	F	G	H	J	K	L
H-235-U	350 Kgs	0.560	60°	85°	68.0	290.0	45.0	41.4	41.4	57.2	57.2	113.0	8.5	70.0	M10 Bolt
H-235-UB	350 Kgs	0.560	60°	85°	81.0	290.0	61.0	41.4	8.0	57.2	-	113.0	8.5	70.0	M10 Bolt

**Horizontal Hold Down Action
H - 213, 217 Series**



Model No. H-213-U



Model No. H-217-UB



Model No. H-217-U

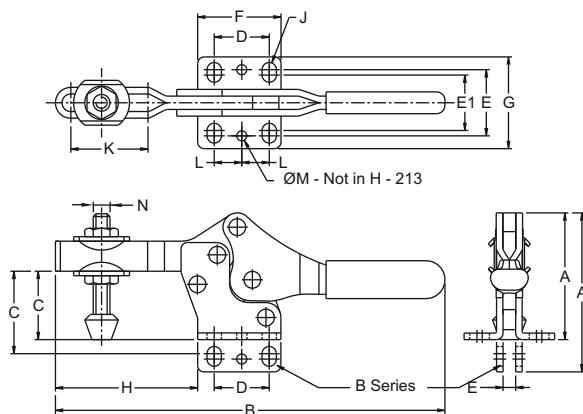

Also Available in Stainless Steel
H-213-U-SS
H-213-UB-SS
H-217-U-SS
H-217-UB-SS

Model No.	Arm Type	Base Type
H-213-U	Adjustable Arm	Flanged
H-213-UB	Adjustable Arm	Straight
H-217-U	Adjustable Arm	Flanged
H-217-UB	Adjustable Arm	Straight

Model No.	Holding Capacity	Weight Kg	Handle Moves	Bar Opens	Dimensions												
					A	B	C	D	E	E1	F	G	H	J	K	M	N
H-213-U	70 Kgs	0.070	60°	90°	36.0	109.0	19.5	13.5	19.0	17.6	25.5	28.0	35.5	4.3 x 5.0	24.0	-	M5 Bolt
H-213-UB	70 Kgs	0.070	60°	90°	44.7	109.0	27.0	13.5	4.0	-	25.5	-	35.5	4.3 x 5.0	24.0	-	M5 Bolt
H-217-U	100 Kgs	0.190	76°	92°	52.0	166.0	27.0	26.2	29.5	23.7	37.6	41.1	63.0	5.5 x 8.5	42.0	4.7	M6 Bolt
H-217-UB	100 Kgs	0.190	76°	92°	63.5	166.0	34.0	26.2	6.0	-	37.6	-	63.0	5.5 x 8.5	42.0	4.7	M6 Bolt

Horizontal Hold Down Action

Horizontal Hold Down Action H - 227, 237, 245 Series



Model No. H-227-U



Model No. H-237-U



Model No. H-245-U



Model No. H-227-UB



Model No. H-237-UB



Model No. H-245-UB



Model No. H-245-S

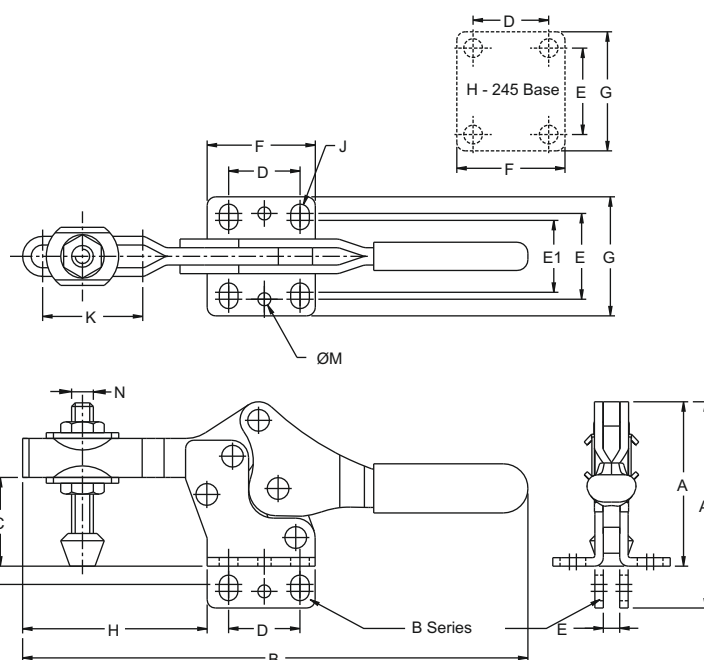

Also Available
in Stainless Steel
H-227-U-SS
H-227-UB-SS

Model No.	Arm Type	Base Type
H-227-U	Adjustable Arm	Flanged
H-227-UB	Adjustable Arm	Straight
H-237-U	Adjustable Arm	Flanged
H-237-UB	Adjustable Arm	Straight
H-245-S	Solid Arm	Flanged
H-245-SB	Solid Arm	Straight
H-245-U	Adjustable Arm	Flanged
H-245-UB	Adjustable Arm	Straight

Model No.	Holding Capacity	Weight Kg	Handle Moves	Bar Opens	Dimensions												
					A	B	C	D	E	E1	F	G	H	J	K	M	N
H-227-U	225 Kgs	0.300	62°	92°	62.0	190.0	34.0	26.2	31.6	26.6	39.6	44.0	72.0	6.8 x 9.4	41.1	4.7	M8 Bolt
H-227-UB	225 Kgs	0.300	62°	92°	76.0	190.0	40.0	26.2	6.0	-	39.6	--	72.0	6.8 x 9.4	41.1	4.7	M8 Bolt
H-237-U	350 Kgs	0.750	63°	92°	80.0	275.0	44.0	41.4	43.0	39.0	57.2	58.0	106.5	8.5 x 10.5	80.0	5.7	M10 Bolt
H-237-UB	350 Kgs	0.750	63°	92°	99.0	275.0	51.6	41.4	8.0	-	57.2	-	106.0	8.5 x 10.5	80.0	5.7	M10 Bolt
H-245-S	450 Kgs	1.400	67°	105°	109.5	325.0	58.0	41.4	41.4	-	66.8	68.6	130.0	8.7	-	-	M12 Bolt
H-245-SB	450 Kgs	1.400	67°	105°	117.0	325.0	65.4	41.4	10.0	-	66.8	-	130.0	8.7	-	-	M12 Bolt
H-245-U	450 Kgs	1.400	67°	105°	109.5	325.0	58.0	41.4	41.4	-	66.8	68.6	130.0	8.7	80.0	-	M12 Bolt
H-245-UB	450 Kgs	1.400	67°	105°	117.0	325.0	65.4	41.4	10.0	-	66.8	-	130.0	8.7	80.0	-	M12 Bolt

HTC Series Clamps - PS Series

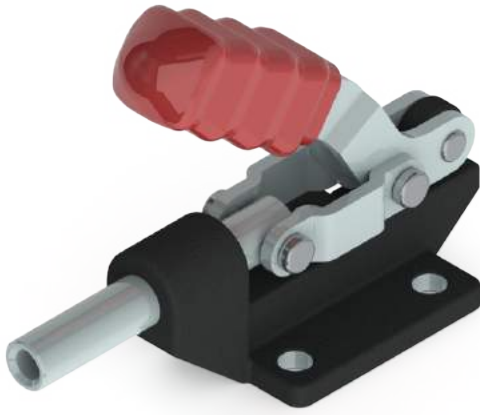

Model No. HTC - 603 - PS

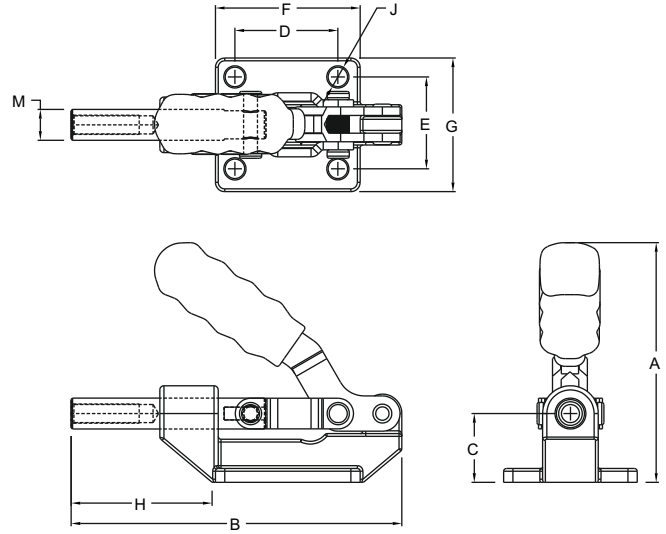

Model No.	Holding Capacity	Weight Kg	Plunger Travel	Plunger Thread	Dimensions									
					A	B	C	D	E	F	G	H	J	M
HTC - 603 - PS	300 Kgs	0.380	31.75	M8 x 1.25	85.5	125	24	36.5	33	52.1	48	52	6.7	11
HTC - 608 - PS	400 Kgs	0.570	41.40	M10 x 1.50	106	153	32	41.4	41.4	57	57	76.8	8.5	15.7
HTC - 610 - PS	400 Kgs	0.870	41.00	M10 x 1.50	121	173	43.2	41.4	41.4	57	57	101	8.5	15.7

HTC Series Clamps - LH Series

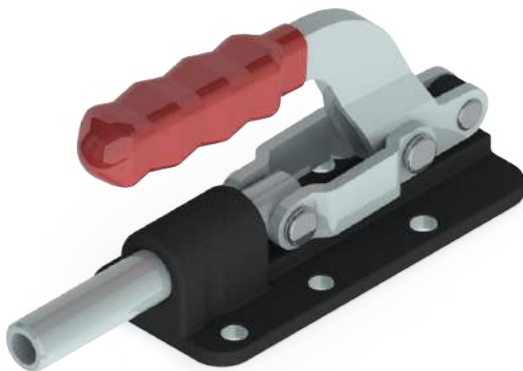

Model No. HTC - 630 - LH

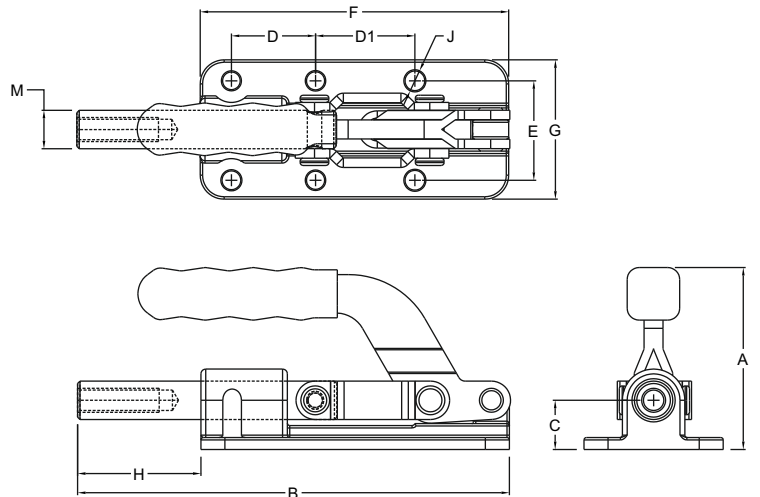

Model No.	Holding Capacity	Weight Kg	Plunger Travel	Plunger Thread	Dimensions										
					A	B	C	D	D1	E	F	G	H	J	M
HTC - 607 - LH	600 Kgs	0.740	41.40	M8 x 1.25	91	153	17.5	35	41.4	41.4	108	56	60	7.0	12.7
HTC - 630 - LH	800 Kgs	0.890	50.80	M10 x 1.50	82	179	20.5	35	41.4	41.4	128.5	58	51	8.5	15.7

Straight Line Action

HTC Series Clamps - 605

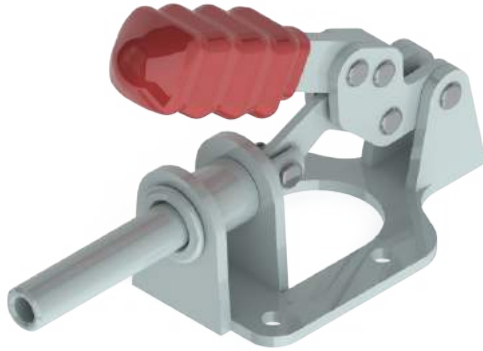

Model No. HTC - 605 - PS

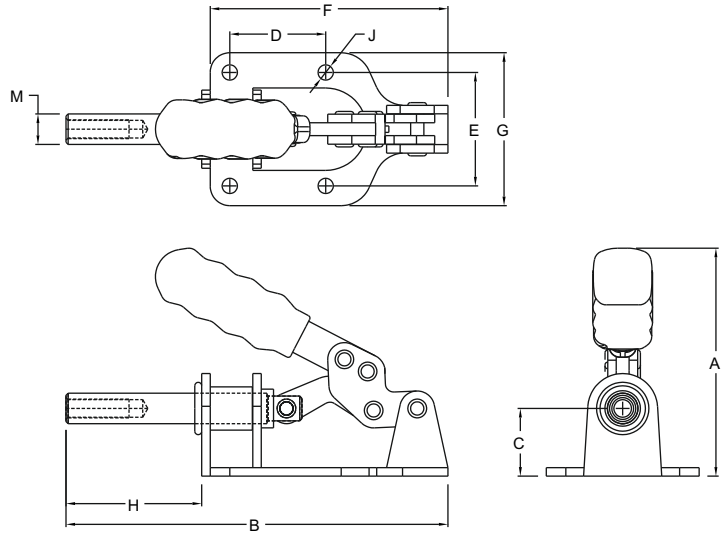

Model No.	Holding Capacity	Weight Kg	Plunger Travel	Plunger Thread	Dimensions									
					A	B	C	D	E	F	G	H	J	M
HTC - 605 - PS	150 Kgs	0.320	31.75	M8 x 1.25	82	139	25	35	41.2	87.5	55.5	49.5	5.6	11.1

HTC Series Clamps - 609

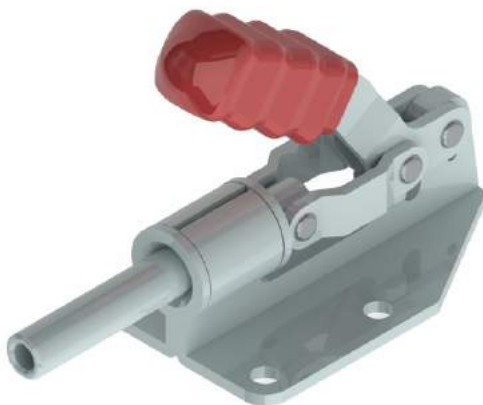

Model No. HTC - 609 - PS

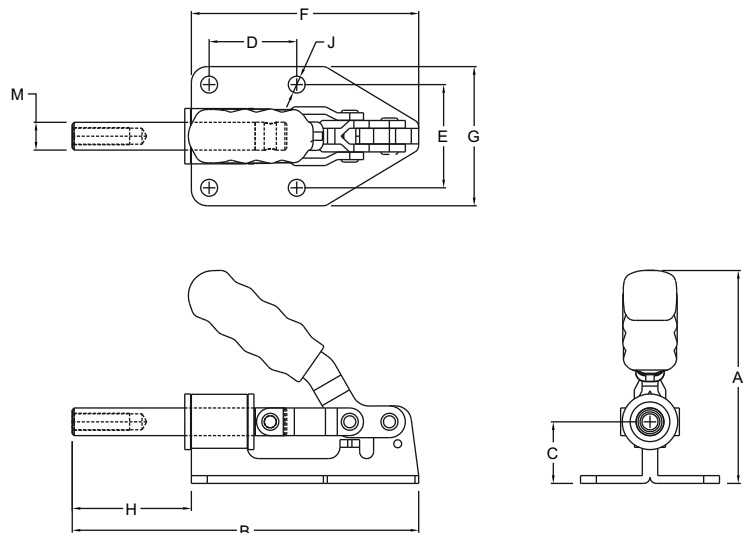

Model No.	Holding Capacity	Weight Kg	Plunger Travel	Plunger Thread	Dimensions									
					A	B	C	D	E	F	G	H	J	M
HTC - 609 - PS	150 Kgs	0.360	32.00	M8 x 1.25	90	139	26	35	41.2	91.5	55.5	47.5	5.2	11.1

Pull Action Clamps

PAH - 301, 311 Series



Model No. PAH - 311

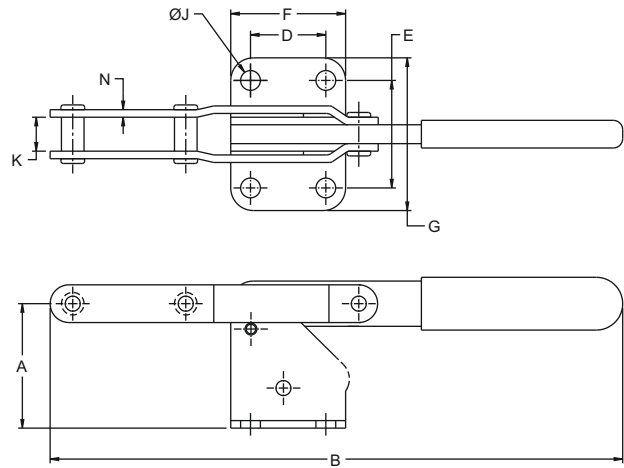

Also Available in Stainless Steel
PAH - 301 - SS
PAH - 311 - SS

Model No.	Holding Capacity	Weight	Drawing Movement	Dimensions								
				A	B	D	E	F	G	J	K	N
PAH-301	170 Kgs	0.300	101.0	41.4	212.3	19.1	31.8	35.1	44.5	7.1	14.2	3.3
PAH-311	550 Kgs	0.550	85.0	52.3	244.6	31.8	45.2	48.5	64.3	8.3	14.2	3.3

PAH - 323, 331, 341 Series



Model No. PAH - 323

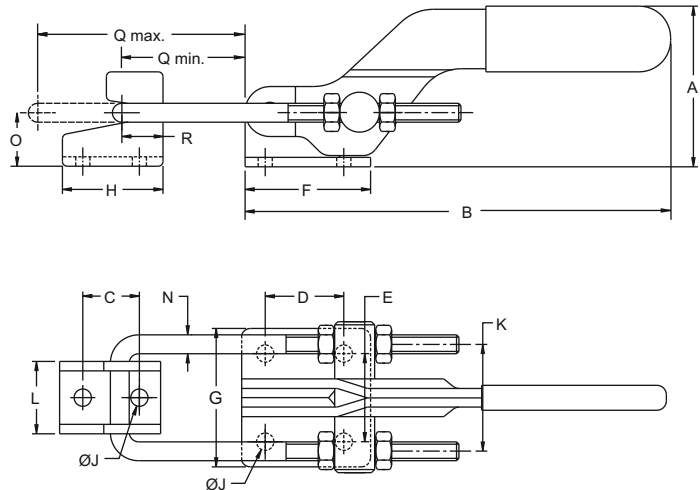

Also Available in Stainless Steel
PAH-323-SS
PAH-331-SS
PAH-341-SS

Model No.	Holding Capacity	Weight	Drawing Movement	Dimensions															
				A	B	C	D	E	F	G	H	ØJ	K	L	ØN	O	Q Min	Q Max	R
PAH-323	150 Kgs	0.100	27.0	32	79.5	10	16	19	26	28	20.3	4.2	19	13.2	4	12	14	27	11
PAH-331	250 Kgs	0.220	44.0	45	123	14.6	19.1	31.8	35.1	45	25.4	6.7	28	17.5	5	16	15.5	45	13
PAH-341	900 Kgs	1.000	63.0	74	168.5	19.1	41.4	38.1	60.6	54.1	38	8.5	44.5	31.2	8	23.7	22	42	19

Optional U-Bolt Configuration

Use the below number for additional long U-Bolts

Model No	U Bolt Part Number	SS - U Bolt Part Number	U	T1	G1	K
PAH - 323	M45725	M45725 - SS	57	25	M4	19.1
PAH - 323 - M25	M48225	M48225 - SS	82			
PAH - 331	M58545	M58545 - SS	85	45	M5	28
PAH - 331 - M25	M511045	M511045 - SS	110			
PAH - 331 - M50	M513545	M513545 - SS	135			
PAH - 341	M811552	M811552 - SS	115	52	M8	44.5
PAH - 341 - M25	M814052	M814052 - SS	140			
PAH - 341 - M50	M816552	M816552 - SS	165			

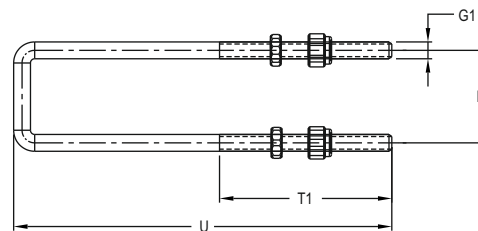

Pull Action Clamps

Model No: PAH-375

Holding Capacity - 1800 kgs
Weight - 2.270 kgs



Model No. PAH - 375

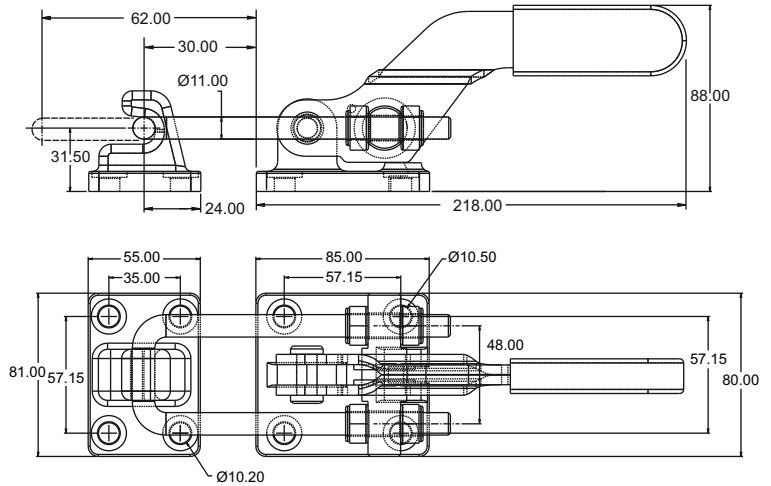

Model No: PAH-385

Holding Capacity - 3500 kgs
Weight - 2.500 kgs



Model No. PAH - 385

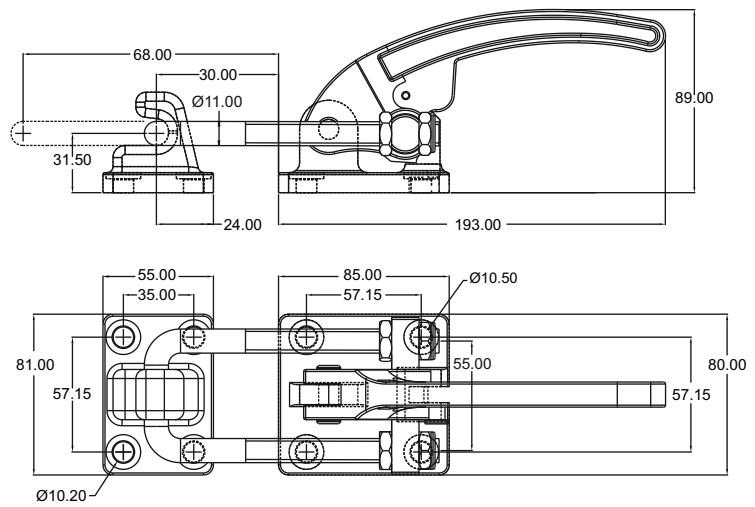

Model No: PAH-385-L

Holding Capacity - 3500 kgs
Weight - 1.650 kgs



Model No. PAH - 385 - L

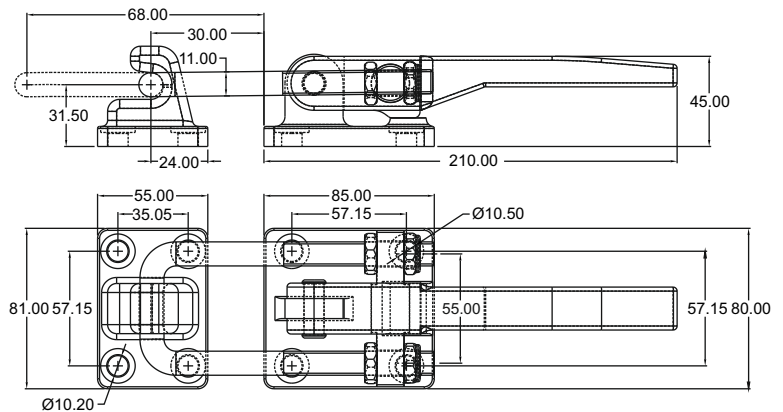

Optional U-Bolt Configuration

Use the below number for additional long U-Bolts

Model No	U Bolt Part Number	U	T1	G1	K
PAH - 375	M1216585	165	85	M12	48
PAH - 375 - M50	M1221585	215			
PAH - 385	M1216585-55	165	85	M12	55
PAH - 385 - M50	M1221585-55	215			
PAH - 385-L	M1216585-55	165			
PAH - 385-L - M50	M1221585-55	215			

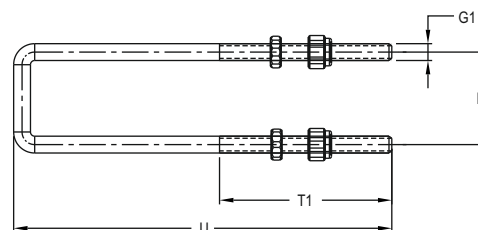

Additional Locking Mechanism

Toggle Clamps with Additional Locking Mechanism

Steel-Smith introduces its latest range of clamps with Additional Locking Mechanism, this mechanism ensures that the clamp remains locked in any condition.

In order to unclamp, the mechanism must be first released. In the Vertical Series this mechanism will hold the clamping arm in both the closed and open positions, so that it is protected against unintentional opening or closing through vibration or if the clamp is mounted overhead.

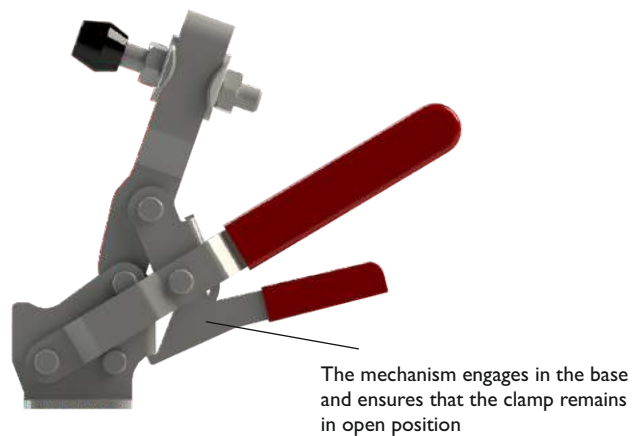
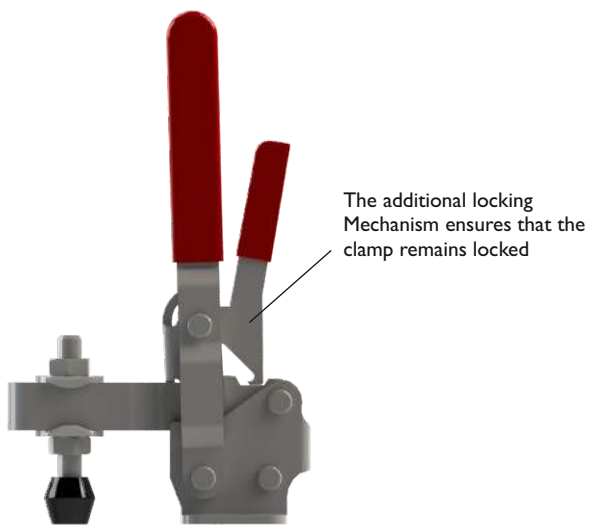
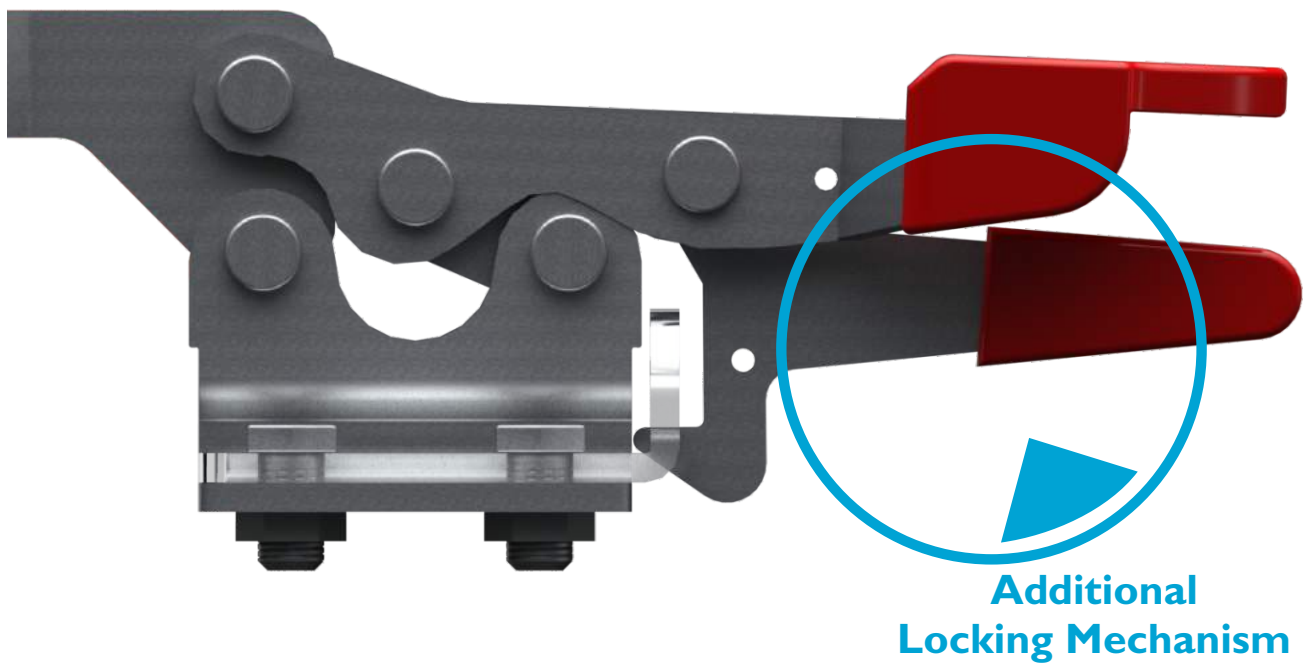

Additional Locking Mechanism

Vertical Hold Down Action With Additional Locking Mechanism

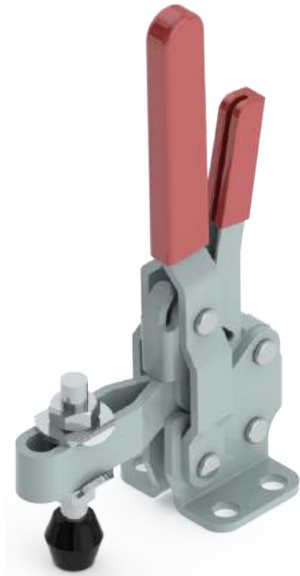

Model No. VTC-207-U-TRIG

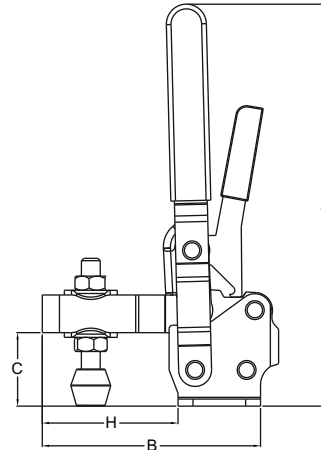
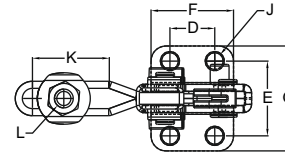

Model No.	Holding Capacity	Weight Kg	Handle Moves	Bar Opens	Dimensions										
					A	B	C	D	E	F	G	H	J	K	L
VTC-207-U-TRIG	175 Kgs	0.300	62°	115°	174.0	100.0	31.0	19.1	31.8	35.1	44.6	57.5	7.1	32.0	M8 Bolt
VTC-210-U-TRIG	275 Kgs	0.590	58°	106°	195.0	144.0	42.0	31.8	45.2	48.6	64.4	91.0	8.3	60.0	M10 Bolt

Horizontal Hold Down Action With Additional Locking Mechanism

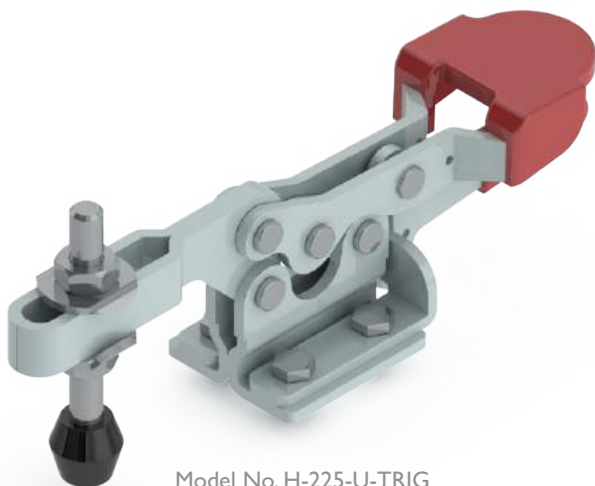

Model No. H-225-U-TRIG

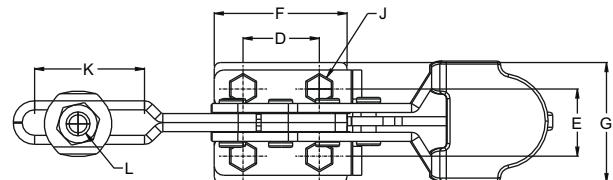
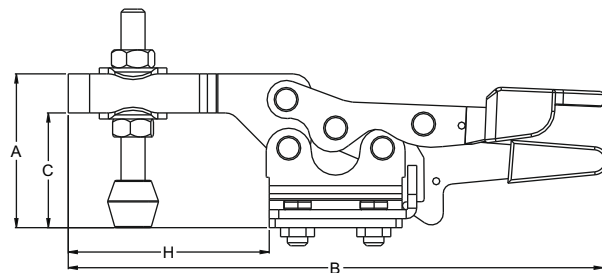

Model No.	Holding Capacity	Weight Kg	Handle Moves	Bar Opens	Dimensions										
					A	B	C	D	E	F	G	H	J	K	L
H-225-U-TRIG	225 Kgs	0.315	70°	90°	47.0	178.5	34.0	25.4	22.4	38.2	35.0	73.5	M6	33.0	M8 Bolt
H-235-U-TRIG	350 Kgs	0.560	60°	85°	71.0	290.0	48.0	41.4	41.4	57.2	57.2	113.0	M8	70.0	M10 Bolt

**HTC Series Clamps - PS Series
With Additional Locking Mechanism**

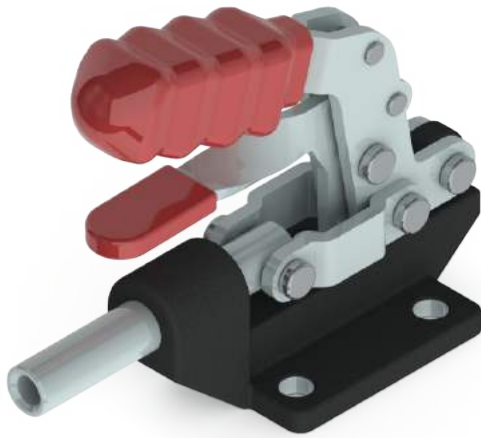

Model No. HTC-603-TRIG

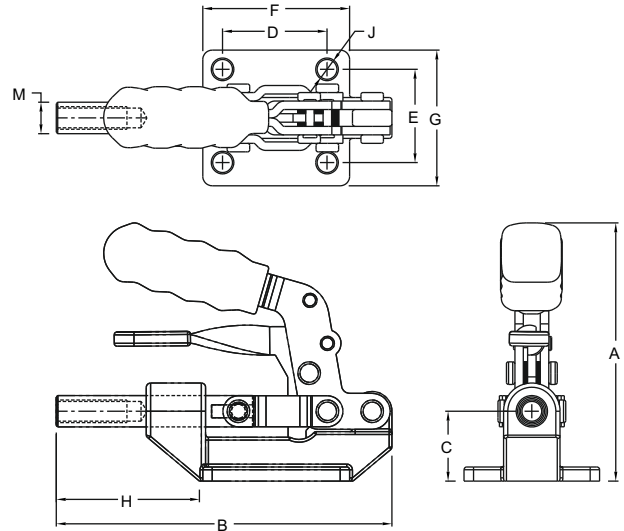

Model No.	Holding Capacity	Weight Kg	Plunger Travel	Plunger Thread	Dimensions									
					A	B	C	D	E	F	G	H	J	M
HTC - 603 - TRIG	300 Kgs	0.380	31.75	M8 x 1.25	87	121	24	36.5	33.0	52	48	52	6.7	11
HTC - 608 - TRIG	400 Kgs	0.570	41.40	M10 x 1.50	106	153	32	41.4	41.4	57	57	76.8	8.5	15.7

**HTC Series Clamps - LH Series
With Additional Locking Mechanism**

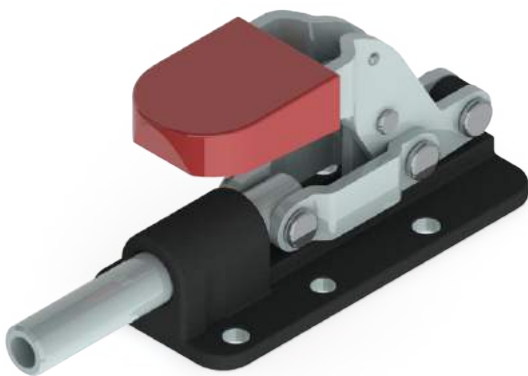

Model No. HTC-630-TRIG

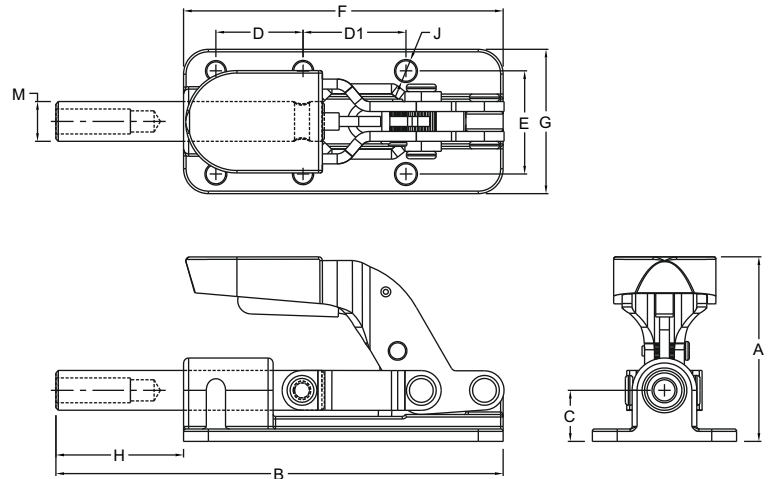

Model No.	Holding Capacity	Weight Kg	Plunger Travel	Plunger Thread	Dimensions										
					A	B	C	D	D1	E	F	G	H	J	M
HTC - 607 - TRIG	600 Kgs	0.740	41.40	M8 x 1.25	91	153	17.5	35	41.4	41.4	108	56	60	7.0	12.7
HTC - 630 - TRIG	800 Kgs	0.890	50.80	M10 x 1.50	82	179	20.5	35	41.4	41.4	128.5	58	51	8.5	15.7

Additional Locking Mechanism

Horizontal Hold Down Action With Additional Locking Mechanism

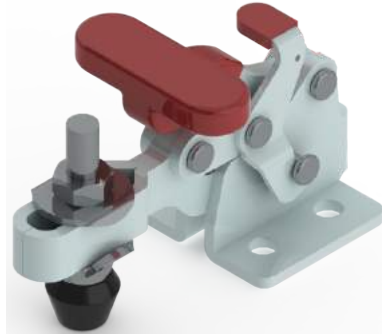

Model No. H - 305 - U - TRIG

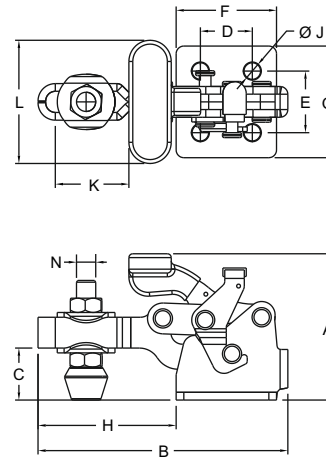

Also Available in Stainless Steel
H-305-U-TRIG-SS
H-307-U-TRIG-SS
H-309-U-TRIG-SS

Model No.	Holding Capacity	Weight Kg	Handle Moves	Bar Opens	Dimensions												
					A	B	C	D	E	F	G	H	J	K	L	N	
H-305-U-TRIG	50 Kgs	0.070	175°	92°	38.0	59.0	13.5	13.5	16.0	26.1	25.4	30.0	4.5	8.0	32.0	M5 Bolt	
H-307-U-TRIG	150 Kgs	0.250	175°	92°	62.0	93.0	23.5	23.0	29.4	43.6	46.6	46.0	7.0	17.0	51.0	M8 Bolt	
H-309-U-TRIG	350 Kgs	0.600	160°	88°	91.2	131.8	33.3	35.1	38.1	64.0	62.7	67.6	8.4	26.9	78.0	M10 Bolt	

Pull Action Clamps With Additional Locking Mechanism

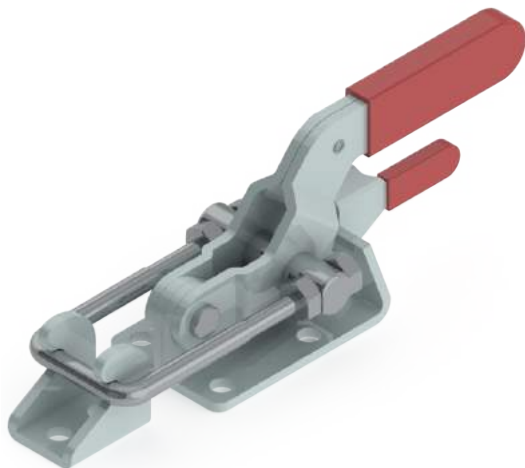

Model No. PAH-341-TRIG

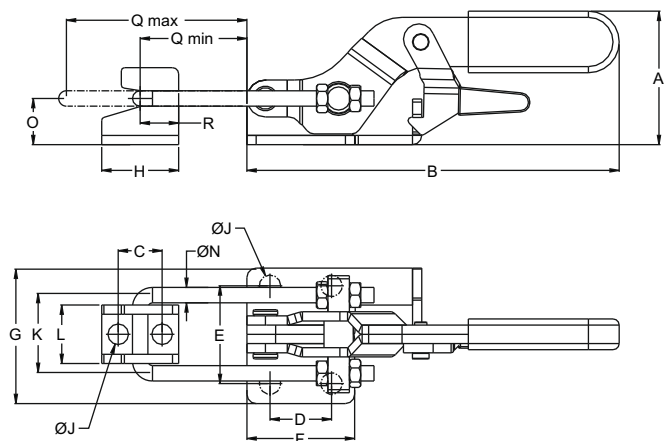

Also Available in Stainless Steel
PAH-331-TRIG-SS
PAH-341-TRIG-SS

Model No.	Holding Capacity	Weight	Drawing Movement	Dimensions															
				A	B	C	D	E	F	G	H	ØJ	K	L	ØN	O	Q Min	Q Max	R
PAH-331-TRIG	325 Kgs	0.250	44.0	45	123	14.6	19.1	31.8	35.1	45	25.4	6.7	28	17.5	5.0	16	15.5	45	13
PAH-341-TRIG	900 Kgs	0.710	63.0	74	168.5	19.1	41.4	38.1	60.6	54.1	38	8.5	44.5	31.2	8.0	23.7	22	42	19

Additional Locking Mechanism

Model No: PAH-5271-TRIG

Holding Capacity - 350 kgs
Weight - 0.370 kgs

Also Available
in Stainless Steel
PAH - 5271 - TRIG - SS

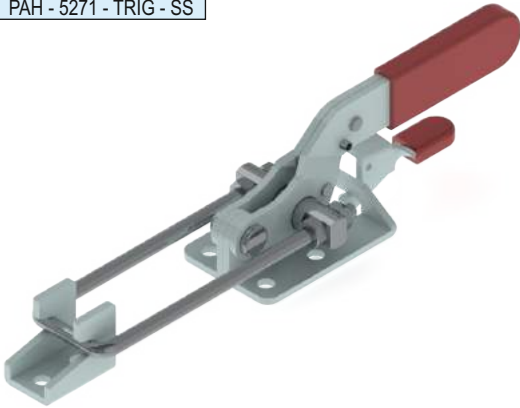

Model No. PAH-5271-TRIG-SS

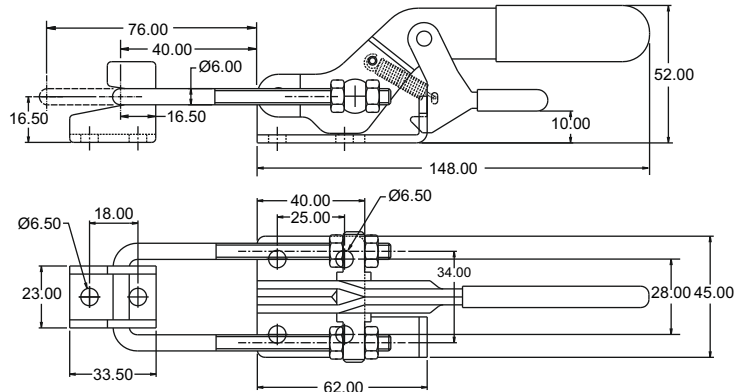

Model No: PAH-5442-TRIG

Holding Capacity - 950 kgs
Weight - 0.920 kgs

Also Available
in Stainless Steel
PAH - 5442 - TRIG - SS

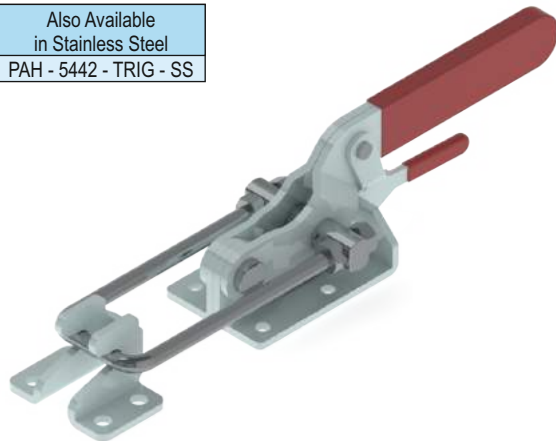

Model No. PAH-5442-TRIG-SS

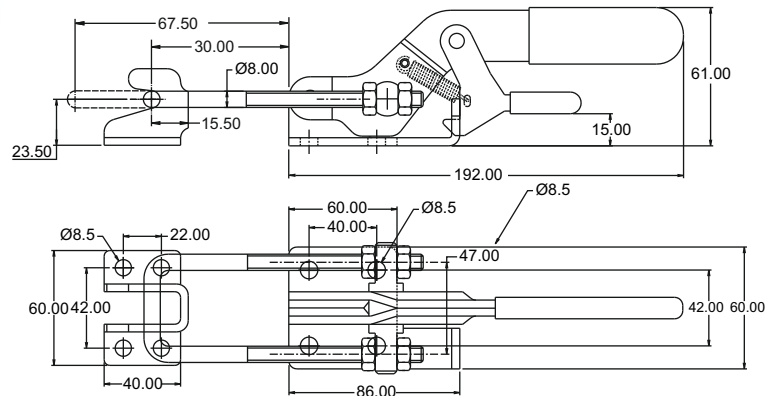

Model No: PAH-2603-TRIG

Holding Capacity - 1800 kgs
Weight - 2.270 kgs

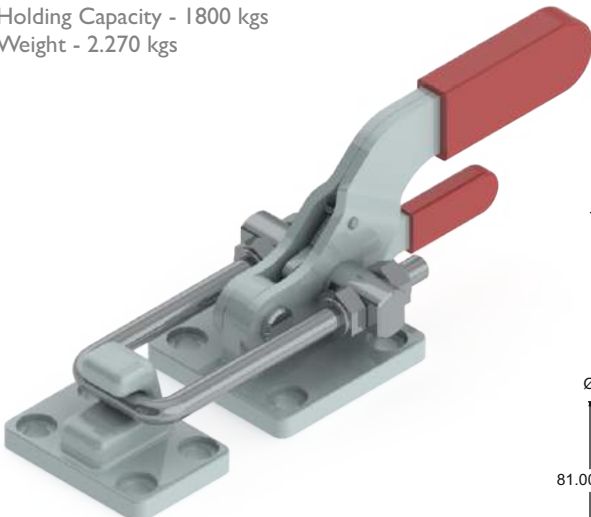

Model No. PAH-2603-TRIG

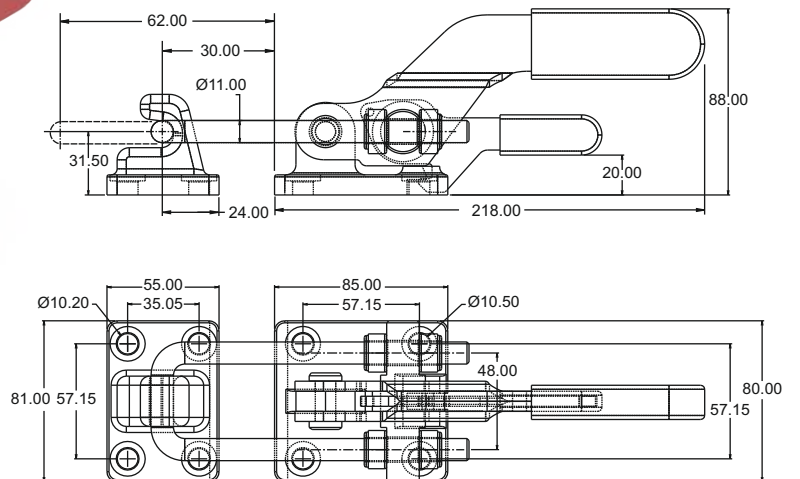

Additional Locking Mechanism

Model No: PAH-385-TRIG

Holding Capacity - 3500 kgs
Weight - 2.500 kgs



Model No. PAH - 385 - TRIG

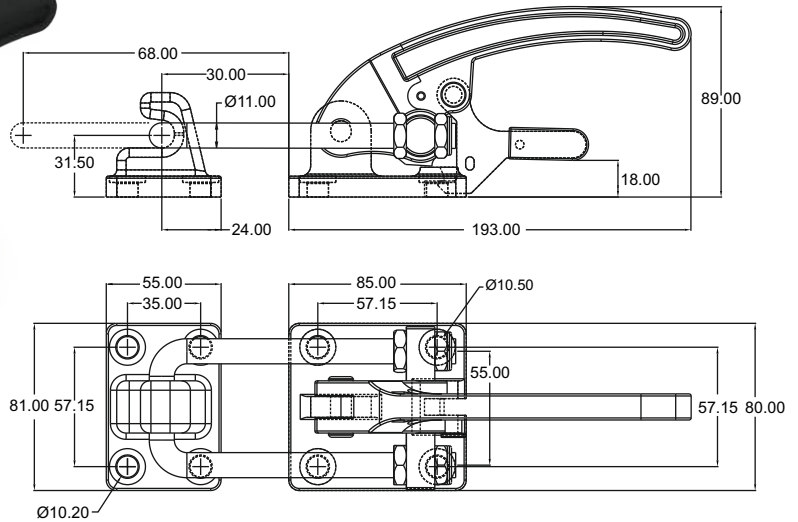

Model No: PA-351-TRIG

Holding Capacity - 200 kgs
Weight - 0.400 kgs

Also Available
in Stainless Steel
PA - 351 - TRIG - SS

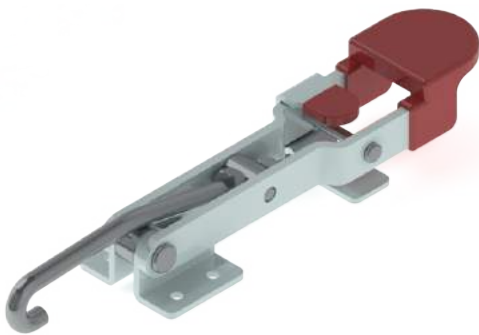

Model No. PA - 351 - TRIG

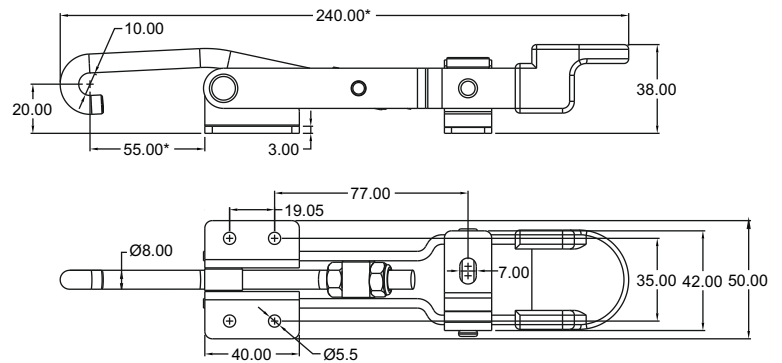

Optional U-Bolt Configuration

Use the below number for additional long U-Bolts

Model No	U Bolt Part Number	SS - U Bolt Part Number	U	T1	G1	K
PAH - 5271-TRIG	M613055	M613055 - SS	130	55	M6	34
PAH - 5271-TRIG - M25	M615555	M615555 - SS	155			
PAH - 5271-TRIG - M50	M618055	M618055 - SS	180			
PAH - 5442-TRIG	M814570	M814570 - SS	145	70	M8	47
PAH - 5442-TRIG - M25	M817070	M817070 - SS	170			
PAH - 5442-TRIG - M50	M819570	M819570 - SS	195			
PAH - 2603-TRIG	M1216585	M1216585 - SS	165	85	M12	48
PAH - 2603-TRIG - M25	M1219085	M1219085 - SS	190			
PAH - 2603-TRIG - M50	M1221585	M1221585 - SS	215			
PAH - 385 - TRIG	M1216585-55	--	165	85	M12	55
PAH - 385 - TRIG - M50	M1221585-55	--	215			

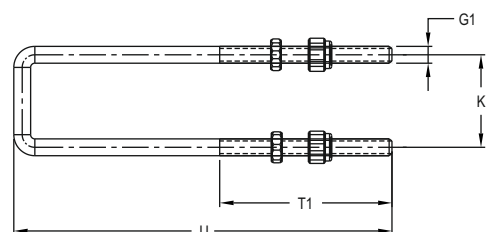

RUBBER TIP SPINDLES - RT

Model No.	A	B	C	D
RT-420	9	24	19	M 4
RT-529	11	29	24	M 5
RT-533	12	33	24	M 5
RT-539	12	39	30	M 5
RT-645	15	46	33	M 6
RT-655	15	55	42	M 6
RT-865	18	66	50	M 8
RT-1085	23	86	66	M 10
RT-12115	23	116	97	M 12
RT-12155	23	163	144	M 12
RT-16170	32	173	147	M 16

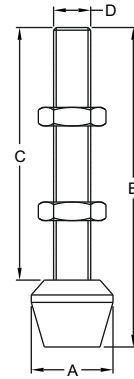

NYLON TIP SPINDLES - NT

Model No.	A	B	C	D
NT-645	15	48	35	M 6
NT-865	18	72	55	M 8
NT-1085	24	90	70	M 10
NT-12115	24	120	102	M 12
NT-12155	24	160	142	M 12
NT-16170	32	173	147	M 16

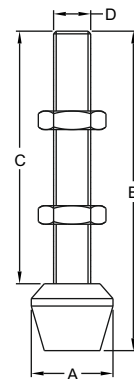

SWIVEL FOOT SPINDLES - SW

Model No.	A	B	C	D
SW-645	12.5	60	36	M 6
SW-865	16	85	63	M 8
SW-1085	19	102	75	M 10
SW-12115	19	133	105	M 12
SW-12155	19	173	144	M 12
SW-16170	50	190	155	M 16

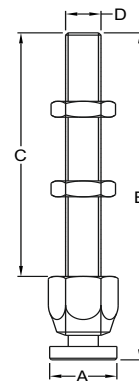

LARGE DIAMETER SWIVEL FOOT SPINDLES - SW

Model No.	A	B	C	D
LDSW-645	25	60	36	M 6
LDSW-865	32	85	63	M 8
LDSW-1085	38	102	75	M 10
LDSW-12115	38	133	105	M 12
LDSW-12155	38	173	144	M 12
LDSW-16170	100	190	155	M 16

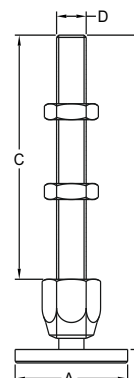

Accessories

STANDARD HEX SPINDLES - SH

Model No.	B	C	D
SH-645	49	45	M 6
SH-865	70	64	M 8
SH-1085	97	90	M 10
SH-12115	132	124	M 12
SH-12155	150	142	M 12
SH-16170	192	181	M 16

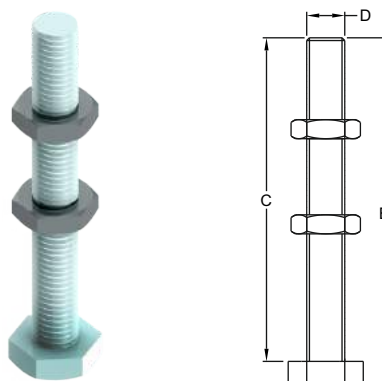

PLAIN SPINDLES - PS

Model No.	C	D
PS-645	46	M 6
PS-865	69	M 8
PS-1085	85	M 10
PS-12115	116	M 12
PS-16170	172	M 16

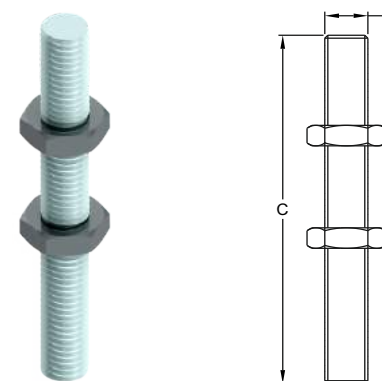

WASHERS

Model No.	A	B	C
M4-WSHR	9	4.2	-
M5-WSHR	15	5.2	9.5
M6-WSHR	19.5	6.2	13.5
M8-WSHR	22.5	8.2	16.5
M10-WSHR	25	10.2	19.5
M12-WSHR	27.5	12.2	21.5
M16-WSHR	31	16.2	29.5

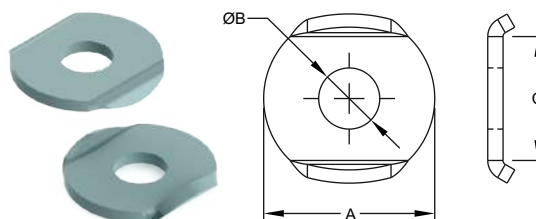

BOLT RETAINER - BR

Model No.	A	B	TØ
BR-1	10	20	6
BR-2	20	27	10
BR-3	20	30	12
BR-4	25	32	16
BR-5	12	23	8
BR-6	20	27	10
BR-7	25	30	12

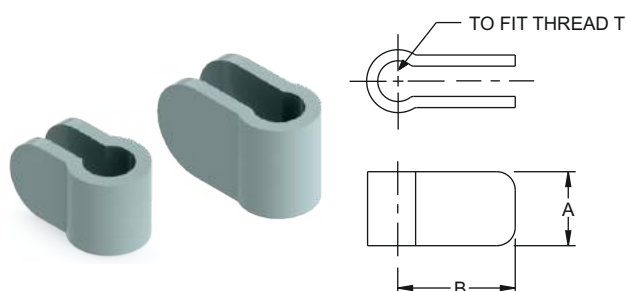

RUBBER CAPS - RC

Model No.	A	B	C	D	For Hex Bolt Size
RC - 512	12.5	10	5	8	M 5
RC - 615	15	12	6	10	M 6
RC - 819	19	15	7.5	13	M 8
RC - 1022	22	17.5	8.5	15	M 10

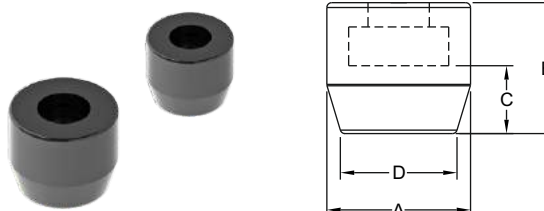

SHIMPACKS SERIES 4015-TML

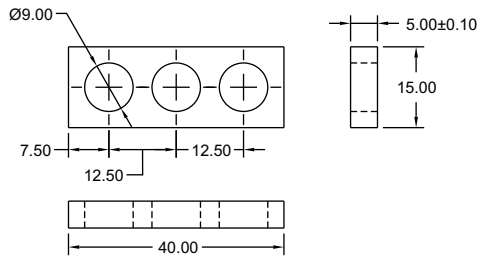
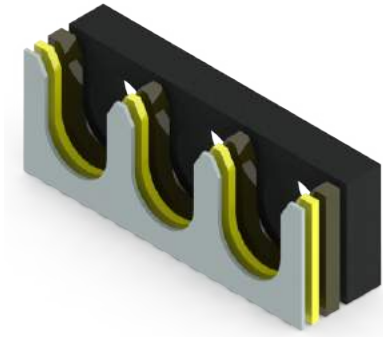

Model No.	NX4015-TML-4
-----------	--------------

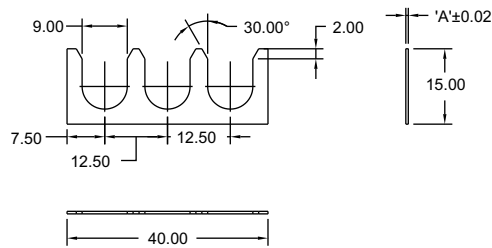
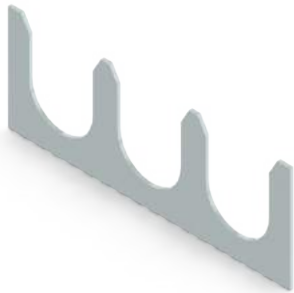

Model No.	Dim 'A'
NX4015-TML-1	0.50 ±0.02
NX4015-TML-2	1.00 ±0.02
NX4015-TML-3	2.00 ±0.02

SHIMPACKS SERIES 4820-TML

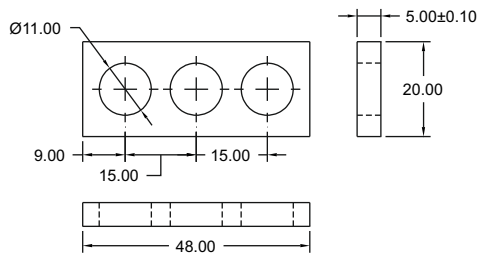
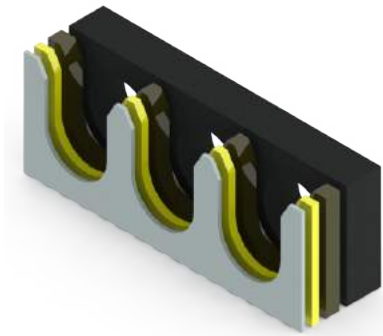

Model No.	NX4820-TML-4
-----------	--------------

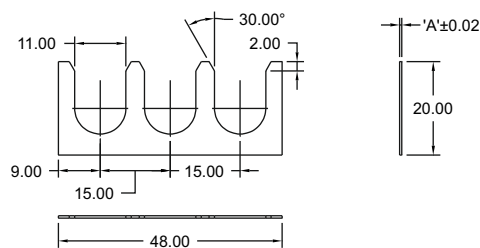
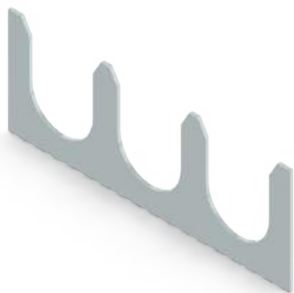

Model No.	Dim 'A'
NX4820-TML-1	0.50 ±0.02
NX4820-TML-2	1.00 ±0.02
NX4820-TML-3	2.00 ±0.02

Shimpacks

SHIMPACKS SERIES 6020-TML

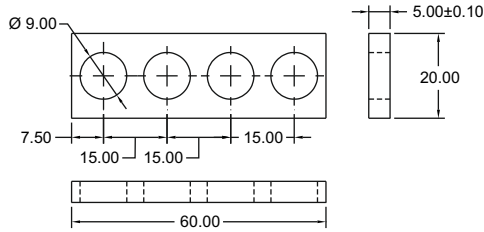
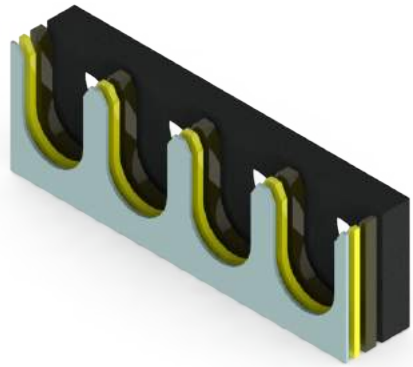

Model No.	NX6020-TML-4
-----------	--------------

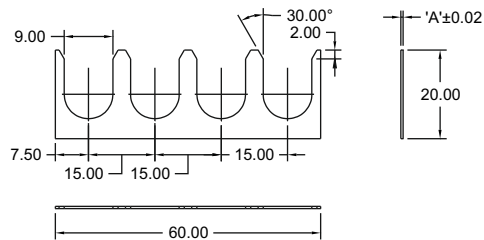
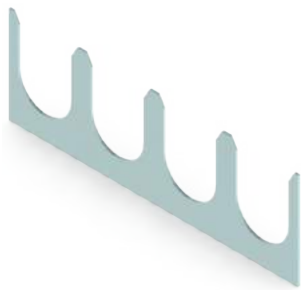

Model No.	Dim 'A'
NX6020-TML-1	0.50 ±0.02
NX6020-TML-2	1.00 ±0.02
NX6020-TML-3	2.00 ±0.02

SHIMPACKS SERIES 8020-TML

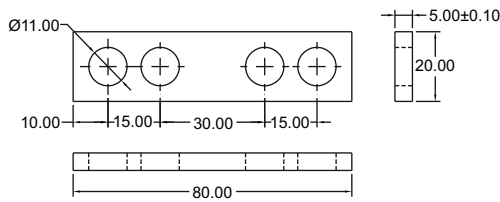
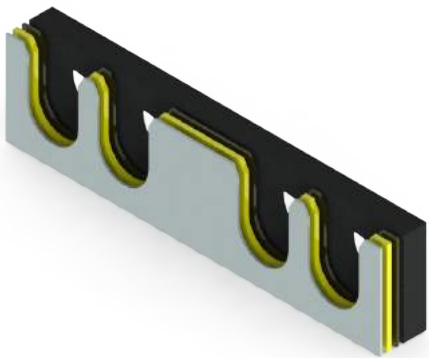

Model No.	NX8020-TML-4
-----------	--------------

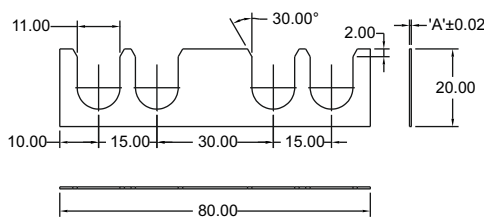
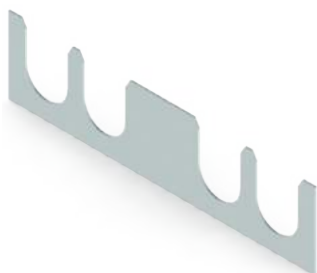

Model No.	Dim 'A'
NX8020-TML-1	0.50 ±0.02
NX8020-TML-2	1.00 ±0.02
NX8020-TML-3	2.00 ±0.02



PLASTIC BASE LEVELING PADS

LEVELING PADS - FEMALE

LEVELING PADS - MALE

FIXTURE HEX NUTS

EXTENSION FIXTURE HEX NUTS

PLAIN WASHERS

SPHERICAL WASHERS - CONICAL SEATS

STUDS FOR T - NUTS

COLLAR NUTS

UNIVERSAL STEP BLOCKS

SPRING PLUNGERS

T - NUTS

T - BOLTS

STRAP CLAMPS

Fixture Elements

TECHNOPOLYMER PLASTIC BASE LEVELING PADS With Rubber Bottom for Anti-Skid (60mm Base)

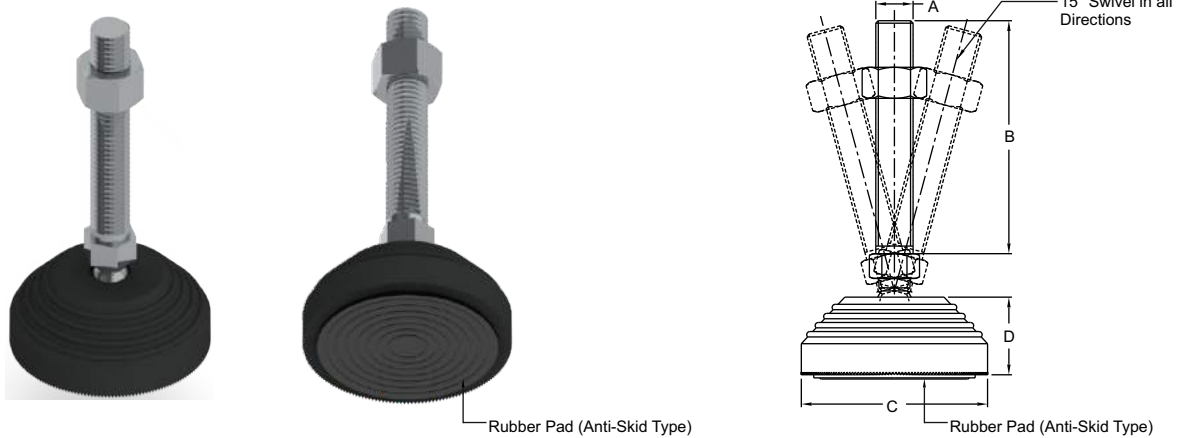

Model No.	A	B	C	D	Max. Load Capacity
TPLP - 1075 - 60	M 10	75	60	24	100 Kgs
TPLP - 10100 - 60	M 10	100	60	24	100 Kgs
TPLP - 10125 - 60	M 10	125	60	24	100 Kgs
TPLP - 1275 - 60	M 12	75	60	24	100 Kgs
TPLP - 12100 - 60	M 12	100	60	24	100 Kgs
TPLP - 12125 - 60	M 12	125	60	24	100 Kgs

Model No.	A	B	C	D	Max. Load Capacity
TPLP - 1675 - 60	M 16	75	60	24	100 Kgs
TPLP - 16100 - 60	M 16	100	60	24	100 Kgs
TPLP - 16125 - 60	M 16	125	60	24	100 Kgs

TECHNOPOLYMER PLASTIC BASE LEVELING PADS With Rubber Bottom for Anti-Skid (80mm Base)

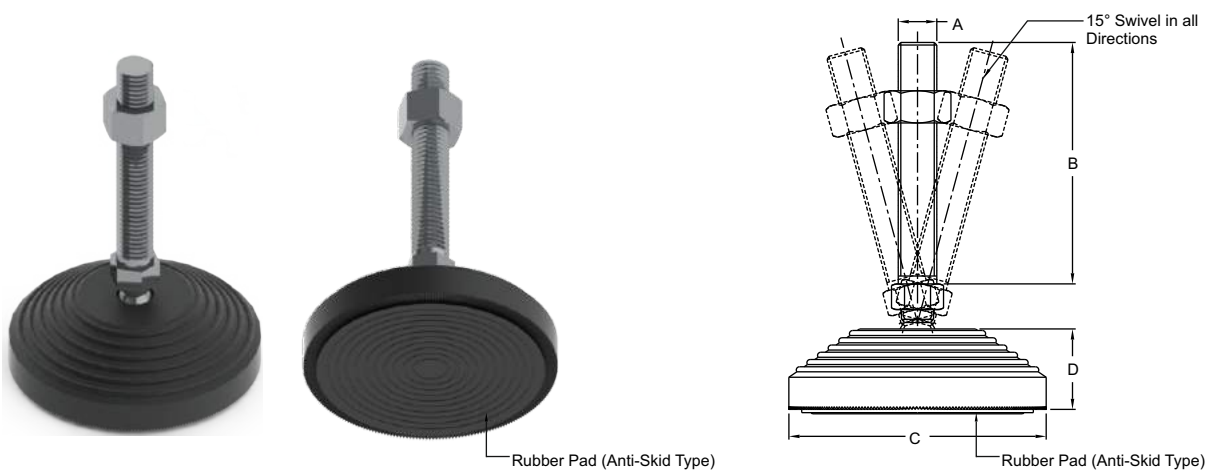

Model No.	A	B	C	D	Max. Load Capacity
TPLP - 1075 - 80	M 10	75	80	22	140 Kgs
TPLP - 10100 - 80	M 10	100	80	22	140 Kgs
TPLP - 10125 - 80	M 10	125	80	22	140 Kgs
TPLP - 1275 - 80	M 12	75	80	22	140 Kgs
TPLP - 12100 - 80	M 12	100	80	22	140 Kgs
TPLP - 12125 - 80	M 12	125	80	22	140 Kgs

Model No.	A	B	C	D	Max. Load Capacity
TPLP - 1675 - 80	M 16	75	80	22	140 Kgs
TPLP - 16100 - 80	M 16	100	80	22	140 Kgs
TPLP - 16125 - 80	M 16	125	80	22	140 Kgs

LEVELING PADS - FEMALE

Model No.	A	B	C	D	E	F	Wt. in Kgs	Max. load capacity for static load kN max.
SLPF-624	M 6	20	14	2.5	5	10	0.017	10
SLPF-825	M 8	25	18	4.0	7.0	13	0.036	18
SLPF-1032	M 10	32	22	5.0	9.0	17	0.077	20
SLPF-1240	M 12	40	26	6.0	11.0	19	0.125	35
SLPF-1650	M 16	50	32	7.0	13.5	24	0.250	45
SLPF-2060	M 20	60	42	8.0	17.0	30	0.480	55
SLPF-2460	M 24	60	45	9.5	19.0	36	0.665	65

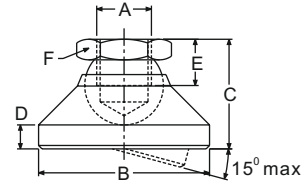

FEATURES:

Material: Steel Quality - Heat Treated
Finish: Black Oxide

LEVELING PADS - MALE

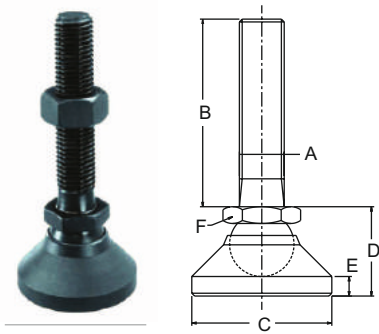

FEATURES:

Material: Steel Quality - Heat Treated
Finish: Black Oxide

Model No.	A	B	C	D	E	F	Wt. in Kgs	Max. load capacity for static load kN max.
SLPM-660	M 6	60	20	14	2.5	10	0.032	10
SLPM-880	M 8	80	25	18	4.0	13	0.064	18
SLPM-10100	M 10	100	32	22	5.0	17	0.130	20
SLPM-10150	M 10	150	32	22	5.0	17	0.155	20
SLPM-12100	M 12	100	40	26	6.0	19	0.210	35
SLPM-12150	M 12	150	40	26	6.0	19	0.255	35
SLPM-16100	M 16	100	50	32	7.0	24	0.400	45
SLPM-16200	M 16	200	50	32	7.0	24	0.540	45
SLPM-20100	M 20	100	60	42	8.0	30	0.740	55
SLPM-20200	M 20	200	60	42	8.0	30	0.950	55
SLPM-24100	M 24	100	60	45	9.5	36	0.850	65
SLPM-24200	M 24	200	60	45	9.5	36	1.145	65

COLLAR NUTS DIN - 633 I

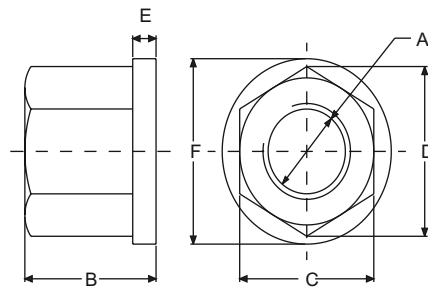

Model No.	A	B	C	D	E	F	Wt. in Kgs
DCCN-812	M 8	12	13	15.0	3.5	18	0.012
DCCN-1015	M 10	15	16	18.5	4.0	22	0.022
DCCN-1218	M 12	18	18	20.8	4.0	25	0.031
DCCN-1624	M 16	24	24	27.7	5.0	31	0.069
DCCN-2030	M 20	30	30	34.6	6.0	37	0.127
DCCN-2436	M 24	36	36	41.6	6.0	45	0.215

Clamping Devices

FIXTURE HEX NUTS

Model No.	A	B	C	D	E	R	Wt. in Kgs
FXN-8120	M 8	9	15	12	13	11	0.010
FXN-10150	M 10	11.5	19.6	15	17	15	0.020
FXN-12180	M 12	14	21.9	18	19	17	0.032
FXN-16240	M 16	18	27.7	24	24	22	0.060
FXN-20300	M 20	22	34.6	30	30	27	0.120
FXN-24360	M 24	26	41.6	36	45	30	0.195
FXN-30450	M 30	32	53.1	45	46	34	0.405

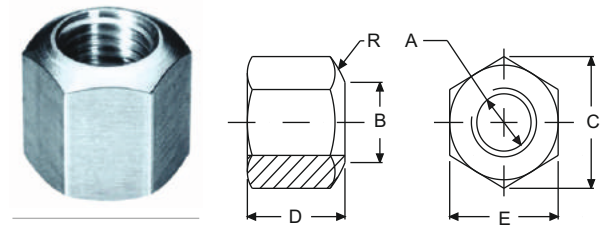

FEATURES:
Material: Steel Quality
Finish: Black Oxide

EXTENSION FIXTURE HEX NUTS

Model No.	A	B	C	D	Wt. in Kgs
EFXN-824	M 8	13	15	24	0.190
EFXN-1030	M 10	17	19.6	30	0.420
EFXN-1236	M 12	19	21.9	36	0.640
EFXN-1648	M 16	24	27.7	48	0.120
EFXN-2060	M 20	30	34.5	60	0.240
EFXN-2472	M 24	36	41.6	72	0.400
EFXN-3090	M 30	45	53.1	90	0.850

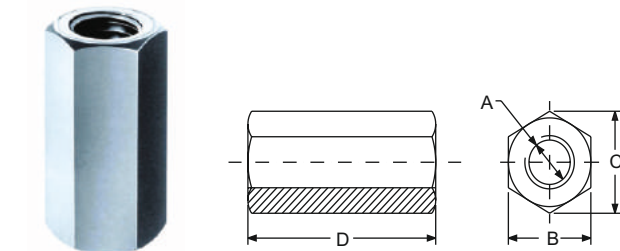

FEATURES:
Material: Steel Quality
Finish: Black Oxide

PLAIN WASHERS - DIN-6340

Model No.	A	B	C	For Bolt	Wt. in Kgs
SPW-84	8.4	23	4	M 8	0.010
SPW-104	10.5	28	4	M 10	0.016
SPW-125	13	35	5	M 12	0.035
SPW-166	17	45	6	M 16	0.060
SPW-206	21	50	6	M 20	0.100
SPW-248	25	60	8	M 24	0.170
SPW-3010	31	68	10	M 30	0.230

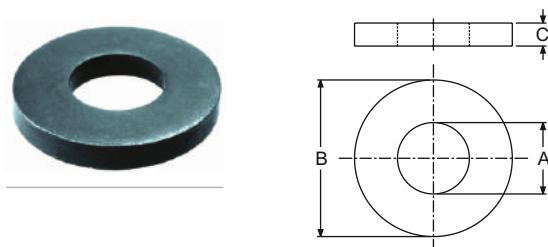

FEATURES:
Material: Heat Treated Steel
Finish: Black Oxide

SPHERICAL WASHERS - CONICAL SEATS DIN - 6319

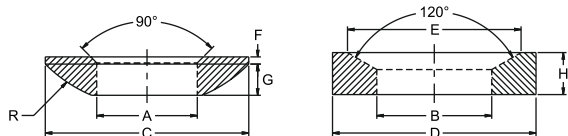

FEATURES:
Material: Heat Treated Steel
Finish: Black Oxide

Model No.	For Bolt	A	B	C	D	E	F	G	H	R	Wt. in Kgs
DSWCS-812	M 8	8.4	9.6	17	17	14.5	0.6	3.2	3.5	12	0.006
DSWCS-1015	M 10	10.5	12	21	21	18.5	0.8	4.0	4.2	15	0.012
DSWCS-1217	M 12	13	14.2	24	24	20.0	1.1	4.6	5.0	17	0.012
DSWCS-1622	M 16	17	19	30	30	26.0	1.3	5.3	6.2	22	0.031
DSWCS-2027	M 20	21	23.2	36	36	31.0	2.0	6.3	7.5	27	0.055
DSWCS-2432	M 24	25	28	44	44	37.0	2.4	8.2	9.5	32	0.100

STUDS FOR T-NUTS DIN-6379



Finish: Black Oxide

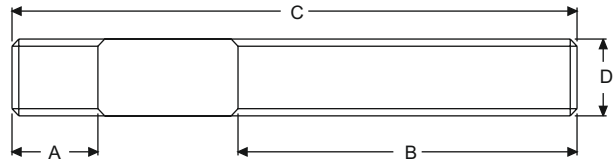

FEATURES:

Material: Heat Treated Steel

Special: Longer or special studs are available on request.

Model No.	A	B	C	D	Wt. in Kgs.
DCS-632	9	16	32	M 6	0.008
DCS-650	9	30	50	M 6	0.011
DCS-663	9	40	63	M 6	0.014
DCS-680	9	50	80	M 6	0.018
DCS-840	11	20	40	M 8	0.010
DCS-863	11	40	63	M 8	0.020
DCS-8100	11	63	100	M 8	0.030
DCS-8160	11	100	160	M 8	0.045
DCS-1080	13	50	80	M 10	0.040
DCS-10100	13	75	100	M 10	0.050
DCS-10125	13	75	125	M 10	0.065
DCS-10160	13	100	160	M 10	0.080
DCS-10200	13	125	200	M 10	0.100
DCS-1280	15	50	80	M 12	0.060
DCS-12100	15	63	100	M 12	0.070
DCS-12125	15	75	125	M 12	0.090
DCS-12200	15	125	200	M 12	0.140
DCS-16100	19	63	100	M 16	0.130
DCS-16125	19	75	125	M 16	0.160
DCS-16160	19	100	160	M 16	0.210

Model No.	A	B	C	D	Wt. in Kgs.
DCS-16200	19	125	200	M 16	0.280
DCS-16250	19	160	250	M 16	0.325
DCS-16315	19	180	315	M 16	0.425
DCS-16500	19	180	500	M 16	0.650
DCS-20125	27	70	125	M 20	0.255
DCS-20160	27	100	160	M 20	0.330
DCS-20200	27	125	200	M 20	0.410
DCS-20250	27	160	250	M 20	0.510
DCS-20315	27	190	315	M 20	0.640
DCS-20400	27	250	400	M 20	0.815
DCS-20500	27	315	500	M 20	1.020
DCS-24100	35	45	100	M 24	0.290
DCS-24125	35	63	125	M 24	0.380
DCS-24160	35	100	160	M 24	0.470
DCS-24200	35	125	200	M 24	0.580
DCS-24250	35	160	250	M 24	0.725
DCS-24315	35	200	315	M 24	0.920
DCS-24400	35	250	400	M 24	1.160
DCS-24630	35	315	630	M 24	1.850

UNIVERSAL STEP BLOCKS



FEATURES:

Material: Heat Treated Steel

Finish: Black Oxide

Note: All three sizes can be combined with one another

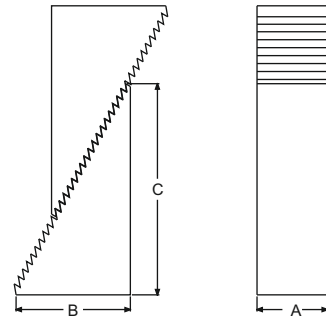

Model No.	A	B	C	Adjustable Height		Wt. in Kgs.
				Min.	Max.	
SSB-5033	24	30	33	22	50	0.110
SSB-10766	40	30	66	38	107	0.220
SSB-210131	73	30	131	69	208	0.490

Clamping Devices

T-NUTS DIN-508

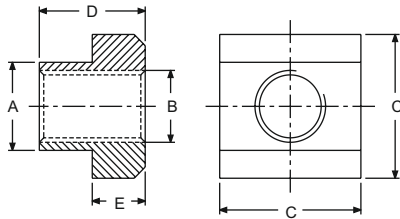

Model No.	T-Slot Size	A	B	C	D	E	Wt. in Kgs
TNSS-108	10	9.6	M 8	15	12	6	0.014
TNSS-128	12	11.6	M 8*	18	14	7	0.022
TNSS-1210	12	11.6	M 10	18	14	7	0.022
TNSS-1410	14	13.6	M 10*	22	16	8	0.034
TNSS-1412	14	13.6	M 12	22	16	8	0.034
TNSS-1612	16	15.6	M 12*	25	18	9	0.050
TNSS-1816	18	17.6	M 16	28	20	10	0.068
TNSS-2016	20	19.6	M 16*	32	24	12	0.107
TNSS-2220	22	21.6	M 20	35	28	14	0.155
TNSS-2420	24	23.6	M 20*	40	32	16	0.220
TNSS-2824	28	27.6	M 24	44	36	18	0.330

T-BOLTS DIN-787

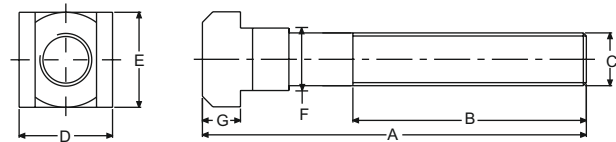

Model No.	T-Slot	A	B	C	D	E	F	G	Wt. in Kgs
TBSS - 850	8	50	35	M 8	13	13	7.6	6	0.025
TBSS - 865	8	65	35	M 8	13	13	7.6	6	0.035
TBSS - 880	8	80	50	M 8	13	13	7.6	6	0.040
TBSS - 1050	10	50	30	M 10	15	15	9.6	6	0.040
TBSS - 1065	10	65	45	M 10	15	15	9.6	6	0.050
TBSS - 1080	10	80	50	M 10	15	15	9.6	6	0.060
TBSS - 10100	10	100	60	M 10	15	15	9.6	6	0.070
TBSS - 1250	12	50	35	M 12	18	18	11.6	7	0.060
TBSS - 1265	12	65	40	M 12	18	18	11.6	7	0.065
TBSS - 1280	12	80	55	M 12	18	18	11.6	7	0.075
TBSS - 12100	12	100	65	M 12	18	18	11.6	7	0.090
TBSS - 12125	12	125	75	M 12	18	18	11.6	7	0.120
TBSS - 12160	12	160	80	M 12	18	18	11.6	7	0.145
TBSS - 12200	12	200	120	M 12	18	18	11.6	7	0.165
TBSS - 12250	12	250	150	M 12	18	18	11.6	7	0.185
TBSS - 1450	14	50	35	M 12	22	22	13.6	8	0.070
TBSS - 1465	14	65	40	M 12	22	22	13.6	8	0.080
TBSS - 1480	14	80	55	M 12	22	22	13.6	8	0.100
TBSS - 14100	14	100	65	M 12	22	22	13.6	8	0.110
TBSS - 14125	14	125	75	M 12	22	22	13.6	8	0.120
TBSS - 14160	14	160	80	M 12	22	22	13.6	8	0.150
TBSS - 14200	14	200	120	M 12	22	22	13.6	8	0.180
TBSS - 14250	14	250	150	M 12	22	22	13.6	8	0.220
TBSS - 1665	16	65	45	M 16	25	25	15.6	9	0.140
TBSS - 1680	16	80	55	M 16	25	25	15.6	9	0.160
TBSS - 16100	16	100	65	M 16	25	25	15.6	9	0.186
TBSS - 16125	16	125	80	M 16	25	25	15.6	9	0.205
TBSS - 16160	16	160	100	M 16	25	25	15.6	9	0.264
TBSS - 16200	16	200	100	M 16	25	25	15.6	9	0.315
TBSS - 16250	16	250	150	M 16	25	25	15.6	9	0.380
TBSS - 16315	16	315	180	M 16	25	25	15.6	9	0.440
TBSS - 1865	18	65	45	M 16	28	28	17.6	10	0.160
TBSS - 1880	18	80	55	M 16	28	28	17.6	10	0.185

Model No.	T-Slot	A	B	C	D	E	F	G	Wt. in Kgs
TBSS - 18100	18	100	65	M 16	28	28	17.6	10	0.203
TBSS - 18125	18	125	65	M 16	28	28	17.6	10	0.235
TBSS - 18160	18	160	100	M 16	28	28	17.6	10	0.280
TBSS - 18200	18	200	125	M 16	28	28	17.6	10	0.330
TBSS - 18250	18	250	150	M 16	28	28	17.6	10	0.430
TBSS - 18315	18	315	180	M 16	28	28	17.6	10	0.530
TBSS - 2080	20	80	55	M 20	32	32	19.6	12	0.290
TBSS - 20100	20	100	65	M 20	32	32	19.6	12	0.340
TBSS - 20125	20	125	85	M 20	32	32	19.6	12	0.390
TBSS - 20160	20	160	110	M 20	32	32	19.6	12	0.470
TBSS - 20200	20	200	125	M 20	32	32	19.6	12	0.550
TBSS - 20250	20	250	150	M 20	32	32	19.6	12	0.670
TBSS - 20315	20	315	190	M 20	32	32	19.6	12	0.800
TBSS - 2280	22	80	55	M 20	35	35	21.6	14	0.330
TBSS - 22100	22	100	60	M 20	35	35	21.6	14	0.400
TBSS - 22125	22	125	85	M 20	35	35	21.6	14	0.428
TBSS - 22125	22	160	100	M 20	35	35	21.6	14	0.500
TBSS - 22200	22	200	125	M 20	35	35	21.6	14	0.570
TBSS - 22250	22	250	150	M 20	35	35	21.6	14	0.680
TBSS - 22315	22	315	190	M 20	35	35	21.6	14	0.820
TBSS - 24100	24	100	70	M 24	40	40	23.6	16	0.540
TBSS - 24125	24	125	85	M 24	40	40	23.6	16	0.640
TBSS - 24160	24	160	110	M 24	40	40	23.6	16	0.770
TBSS - 24200	24	200	125	M 24	40	40	23.6	16	0.900
TBSS - 24250	24	250	150	M 24	40	40	23.6	16	1.040
TBSS - 24315	24	315	190	M 24	40	40	23.6	16	1.270
TBSS - 28100	28	100	70	M 24	44	44	27.6	18	0.650
TBSS - 28125	28	125	75	M 24	44	44	27.6	18	0.720
TBSS - 28160	28	160	110	M 24	44	44	27.6	18	0.800
TBSS - 28200	28	200	125	M 24	44	44	27.6	18	0.950
TBSS - 28250	28	250	150	M 24	44	44	27.6	18	1.120
TBSS - 28315	28	315	160	M 24	44	44	27.6	18	1.350
TBSS - 28400	28	400	250	M 24	44	44	27.6	18	1.500

STRAP CLAMP FLAT DIN-6134

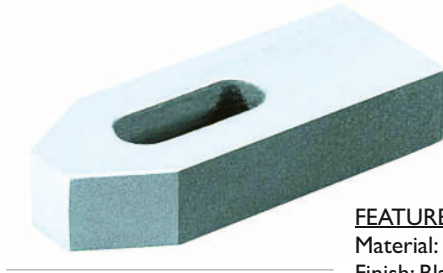

FEATURES:
Material: Heat Treated Steel
Finish: Black Oxide

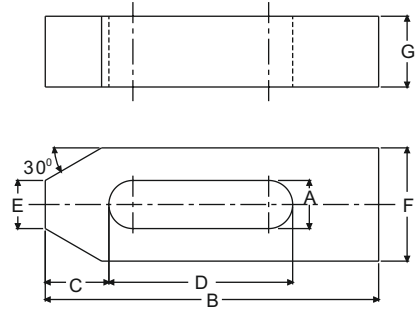

Model No.	A	B	C	D	E	F	G	For Bolt	Wt. in Kgs
SCF-860	9	60	13	22	10	25	12	M 8	0.110
SCF-1080	11	80	15	30	12	30	16	M 10	0.220
SCF-12100	14	100	21	40	14	40	20	M 12	0.490
SCF-12125	14	125	21	50	14	40	20	M 12	0.600
SCF-16125	18	125	26	45	18	50	25	M 16	1.000
SCF-16160	18	160	26	65	18	50	25	M 16	1.200
SCF-20160	22	160	30	60	22	60	30	M 20	1.830
SCF-20200	22	200	30	80	22	60	30	M 20	2.290
SCF-24200	26	200	30	80	26	70	40	M 24	3.400
SCF-24250	26	250	35	105	26	70	40	M 24	3.850

OPEN-ENDED STRAP CLAMP FLAT DIN -6135-B

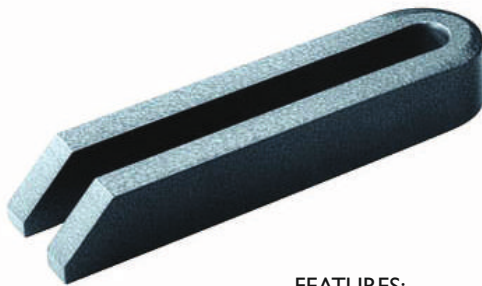

FEATURES:
Material: Heat Treated Steel
Finish: Black Oxide

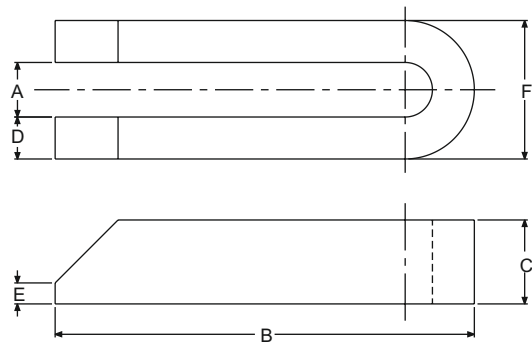

Model No.	A	B	C	D	E	F	For Bolt	Wt. in Kgs
UFS-880	9	80	15	8	4	25	M 8	0.150
UFS-10100	11	100	20	10	5	31	M 10	0.300
UFS-12125	14	125	25	12	6	38	M 12	0.570
UFS-12160	14	160	25	12	6	38	M 12	0.730
UFS-12200	14	220	25	12	6	38	M 12	0.910
UFS-16160	18	160	30	16	8	50	M 16	1.080
UFS-16200	18	200	30	16	8	50	M 16	1.360
UFS-16250	18	250	30	16	8	50	M 16	1.700
UFS-20200	22	200	40	20	10	62	M 20	1.800
UFS-20250	22	250	40	20	10	62	M 20	3.020
UFS-20315	22	315	40	20	10	62	M 20	3.830
UFS-24200	26	200	40	20	10	66	M 24	2.400
UFS-24250	26	250	40	20	10	66	M 24	3.050
UFS-24315	26	315	40	20	10	66	M 24	3.830

Pneumatic Clamps

The sheer power of air clamping at your command

Steel-Smith Pneumatic Toggle Clamps combine the unfaltering Steel-smith toggle action with the speed and efficiency of pneumatic actuators.

These clamps yield high-speed operations with secure and finely controlled clamping pressures. Any number of these clamps can be operated instantly at the touch of a switch and where required they can be arranged to operate in any desired clamping sequence. Pneumatic Toggle Clamps are available in a variety of actions and models to meet the various clamping requirements.

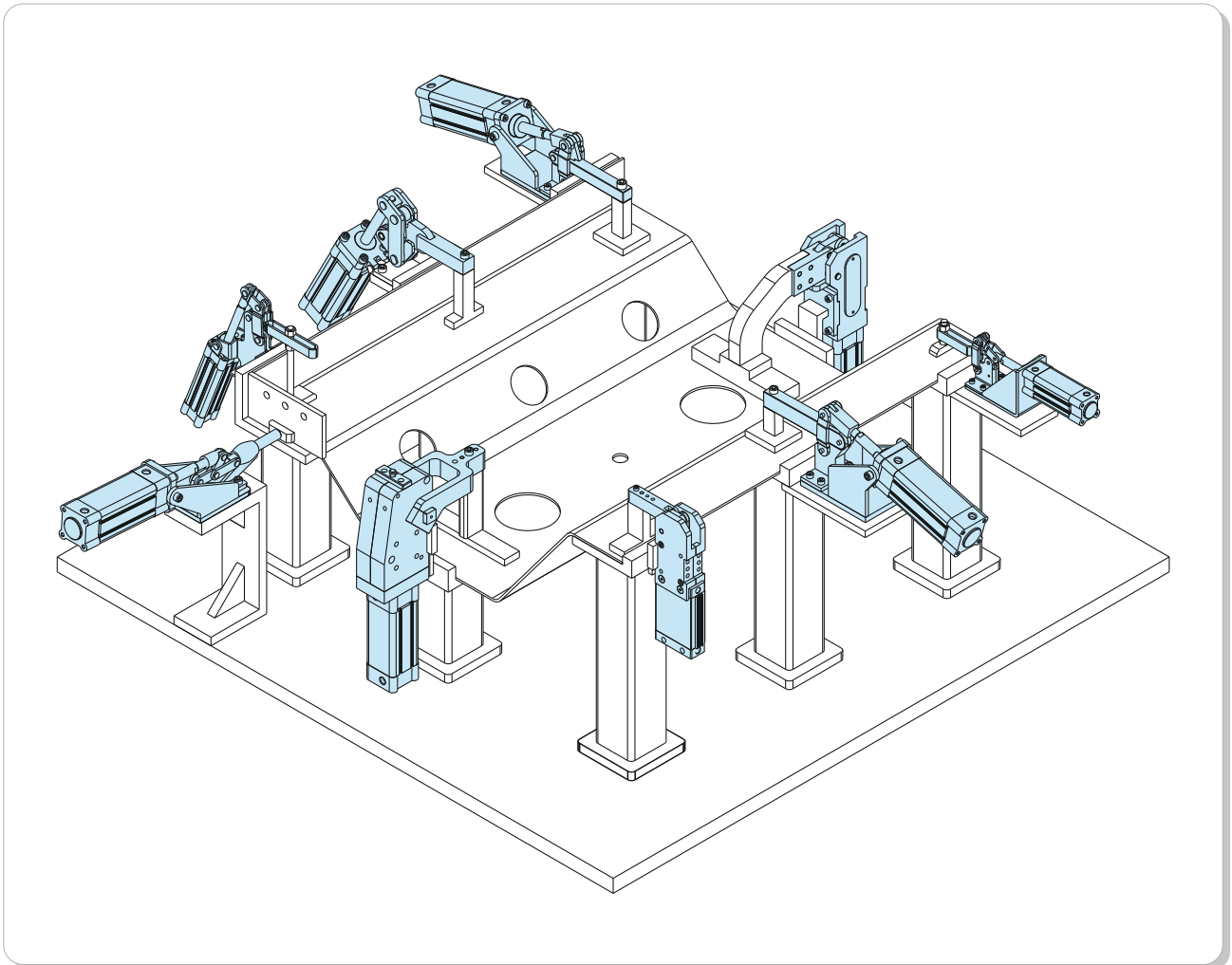

Advantages:

- Pneumatic Toggle Clamps relieve operator of strenuous clamping movement
- A number of clamps can be used simultaneously
- A number of clamps with different sequences can be simultaneously operated
- One or more clamps can be controlled from the machine panel
- One or more clamps can be operated from different positions
- Clamps stay locked in the event of air failure
- Low air consumption with maximum leverage
- Large opening angle ensures easy component removal
- Assurance of a maximum power-to movement ratio
- Production time is reduced by 40%

Introduction

What is a Pneumatic Toggle Clamp?

A Pneumatic Toggle clamp is a basically a Toggle Clamp actuated with a double acting pneumatic cylinder.

The Clamps consists of a double acting cylinder, a clamping arm, linkages for multiplying the applied force, and a base for mounting at the workplace on its base.

Air pressure is applied in the clamping port, which thereby moves the clamping arm to hold the work piece. A required clamping force is achieved and exerted on the work piece. Under this action the Toggle Clamp Holds the work piece firmly and positively. To unlock the clamp the air pressure is applied in the unclamping port.

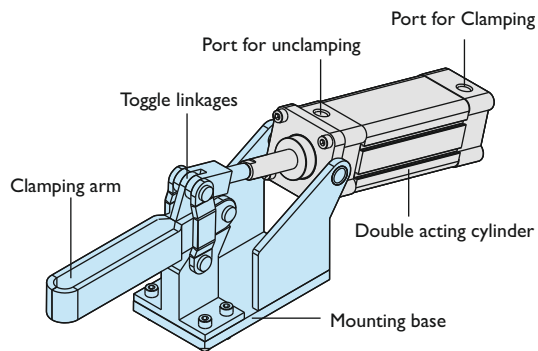

Pneumatic Toggle Action Force Factors

Holding Capacity:

The holding capacity mentioned for each clamp refers to the maximum force, which the clamp can withstand after being over-centered without damage to the clamp and without the toggle unlocking due to distortion of the clamp.

The over-center dimension is carefully chosen in relation to the elasticity of the clamp to maximize clamping force while ensuring that the clamp locks closed even under vibration or intermittent loading.

For Hold Down Clamps, holding capacity is measured with the spindle at the nearest end of the clamping arm and will decrease as the spindle goes farther away from the clamping arm. In cases of DCTC & SSC series the holding capacity is measured considering the specified arm length and if the arm length is increased the holding capacity will decrease accordingly.

Clamping Force:

Clamping Force, the amount of force actually applied to the work piece by closing and locking the clamp, is generally less than the stated holding capacity. Actual clamping force depends on many factors including; spindle position (clamping arm length), cylinder bore, cylinder area, available air pressure and the clamps mechanical advantage. In most cases, the Clamping force is roughly 2 to 3 times the force exerted by the pneumatic cylinder.

Clamping Arm Lengths:

Steel Smith strongly recommends using of clamping arms as per its specified data. Using heavier and longer clamping arms on smaller clamps may disturb the smooth movement of the clamp linkages and also a higher wear and tear in its pins & bushes. Please ask for data sheets on each clamp to know the maximum permissible clamp arm usage for that particular clamp.

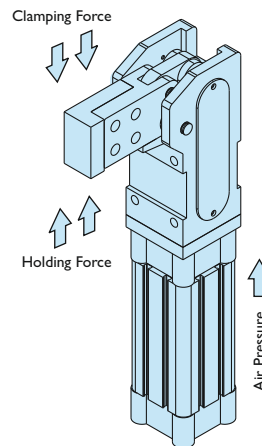

Toggle Principle:

Toggle action clamps operate through a linkage system of levers and pivots. The fixed length levers, connected by pivot pins supply the action and clamping force. Toggle action has an over center lock point which is a fixed stop and linkage. Once in the over center position, the clamp cannot move or unlock unless the linkage is moved. All types of toggle clamps have same action, just oriented differently.

The Toggle Mechanism in a clamp has three functions:

- 1) To multiply applied load at the handle into a high clamping force to hold the work piece.
- 2) To create an over - center lock to prevent the clamp from opening & releasing the work piece until opened by the operator.
- 3) To rapidly open & close the clamp giving a maximum clearance in which to load & unload the work piece.

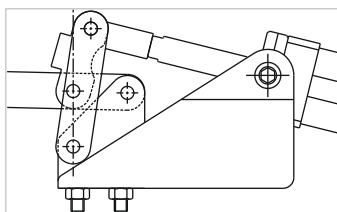

Unclamped

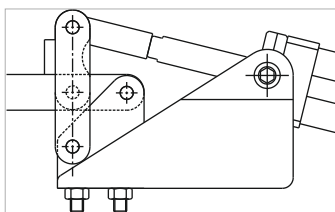

Center position

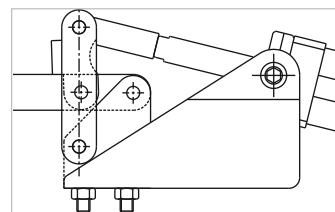

Over-center, clamped position

Pneumatic Clamps

Types of Pneumatic Clamps

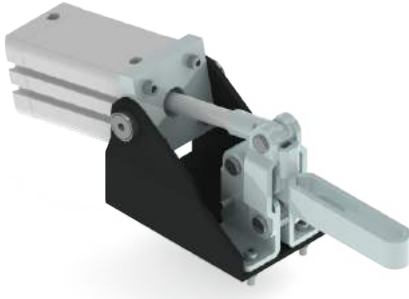

Hold Down Action - Pneumatic Clamps

These clamps utilize the same basic design and operation as manual hold down, only they are operated pneumatically. As the clamp uses the toggle action principle it ensures that the clamp stays locked in the event of air failure. These clamps are extremely compact in design and feature a very low height, allowing free movement of operating tools in drilling, tapping, milling etc. The clamp units are completely self contained with a double acting cylinder and require only to be connected to the air line. The clamping arm exhibits a minimum 95° opening angle for easy unloading of workpiece and is available in two different options.

Hold Down Action - Pneumatic Clamps Fixed Cylinder

These Fixed Cylinder clamps are identical to the Hold Down Action Pneumatic clamps with the exception of Cylinder Mounting design. The outstanding characteristic of the clamp is that the cylinder does not move at all while the clamp is in operation. As there is no movement in the cylinder, fixed solid tubing can be used instead of flexible tubing in welding applications. The clamping arm exhibits a minimum 80° opening angle for easy unloading of workpiece and is available in two different options.

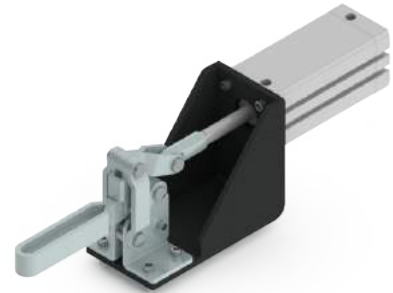

Right Angle Hold Down Clamps

Primarily these clamps belong to the same family of pneumatical hold down clamps with a exception of mounting flexibility. These clamps utilize the same basic design and operation as the pneumatic hold down clamps. In addition these clamps have a flexibility of mounting themselves on the side of the fixture and can also be mounted on top of the fixture. The clamps are used where a right angle model is desirable due to the space constraint. These clamps are nomenclatured as Right Angle Hold Down Clamps as the position of the cylinder is in the downwards perpendicular direction to the clamping unit. Due to these features these clamps can be accommodated in lesser area than the hold down clamps. The clamping arm exhibits a maximum 95° opening and is available in two different options. The typical applications of these clamps are on rotary indexing tables, wood working, injection moulding, PU mould closures, etc.

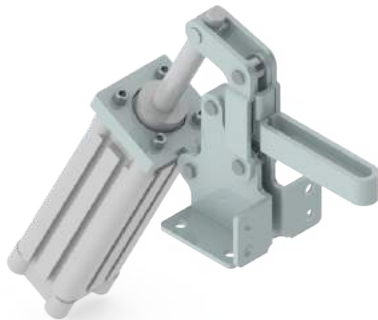

H.V. Series Pneumatic Clamps

These clamps are the air powered version of the manual H.V. Series. They comprise of a very strong and rugged toggle mechanism actuated by a double acting cylinder. The clamping arm is provided with the clamp and can be welded at any desired angle to suit the individual requirement of work pieces. These clamps carry the 'Over Centre Toggle Lock' principle for maximum safety as they remain in locked condition even in case of air failure. The clamps have almost all the features of the manual H.V. Series clamps. These clamps are available in three sizes off the shelf.



Straight Line Action Clamps

These clamps utilize the same basic design as manual straight line action clamps with an exception of pneumatic actuation. They are completely self contained with a double acting cylinder suitable to the clamp design and only need pressurised air connection. These cylinders are mounted in line with the plunger of the clamp. The to-and-fro motion of the cylinder operates the clamp. The cylinder piston extends the plunger of the clamp to achieve the lock position and vice versa for unlocking the clamp. The clamp plunger is drilled and tapped for easy loading of suitable adaptors. Plungers are hardened and ground which run in closed toleranced holes for smooth and accurate functioning of clamps. These clamps are widely used in fixtures where locating of components or holes is required and also in mini-automized presses.

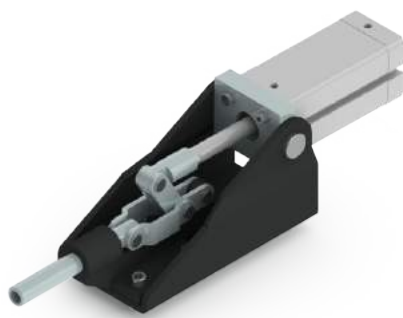

SSC-Series Pneumatic Clamps

SSC Series Pneumatic Clamps are the solution to applications, which demands 'Precision', 'Performance' and the most important factor as far as fixturing is concerned 'Compactness'. These clamps have been specially designed by gathering information and suggestions from customers presently using Steel-Smith pneumatic clamps. The design helps a fixture manufacturer as far as space constrains is concerned.

These clamps are flexible from the maintenance point of view, with features like compatible to all standards, brands and types of pneumatic cylinders. The linkages, connector to piston rod, and the clamping device consists hardened bushings and pivot pins which are easily replaceable in case of wear outs. The clamping device comes with mounting holes, which can be according to the customer's requirement helping them to standardize on their clamping adaptors. The Mounting of the clamp can also be customized in case of substitutes. SSC - Series pneumatic clamps are available in cylinder size from 16mm bore to 63mm bore size.



Hold Down Action

Model No: AOT - 2535 UB

Operating Pressure: 2 - 6 Bar
 Holding Capacity: 100 Kgs.
 Cylinder Stroke: 40mm
 Cylinder Bore: 16mm
 Port Size: M5

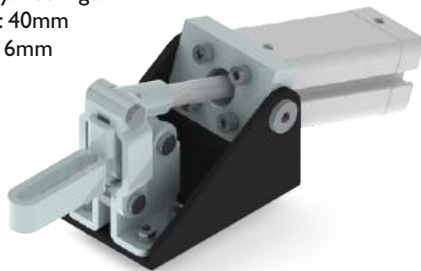

Clamp Arm Opening: 92°

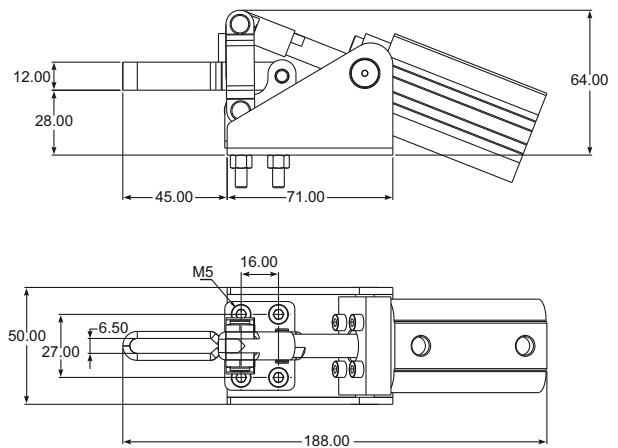

Pneumatic Clamps

Hold Down Action

Model No: AOT - 3586 UB

Operating Pressure: 2 - 6 Bar
 Holding Capacity: 250 Kgs.
 Cylinder Stroke: 50mm
 Cylinder Bore: 25mm
 Port Size: M5

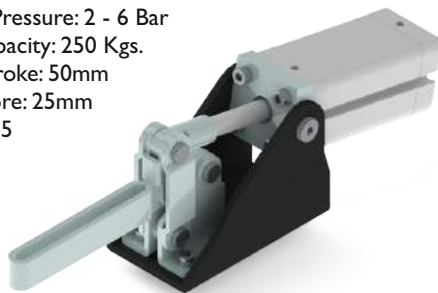

Clamp Arm Opening: 95°

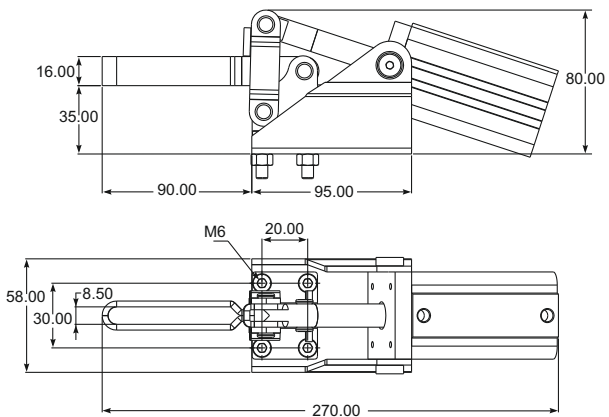

Model No: AOT - 3586 SB

Operating Pressure: 2 - 6 Bar
 Holding Capacity: 250 Kgs.
 Cylinder Stroke: 50mm
 Cylinder Bore: 25mm
 Port Size: M5

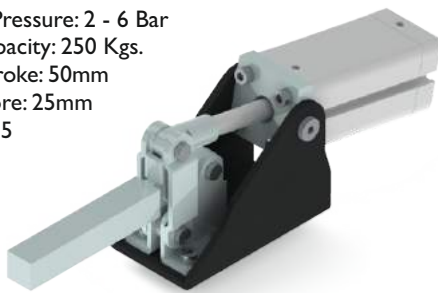

Clamp Arm Opening: 95°

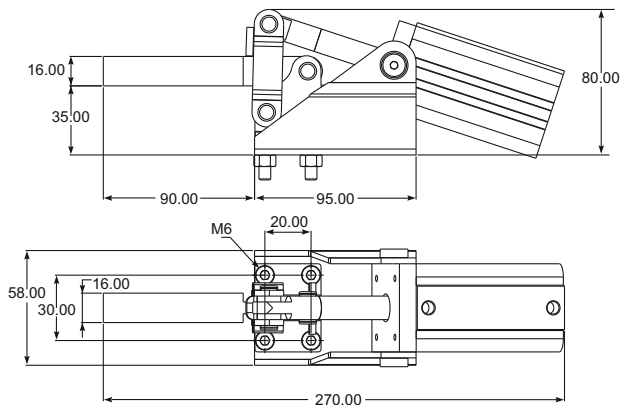

Model No: AOT - 4690 UB

Operating Pressure: 2 - 6 Bar
 Holding Capacity: 500 Kgs.
 Cylinder Stroke: 60mm
 Cylinder Bore: 40mm
 Port Size: G1/8

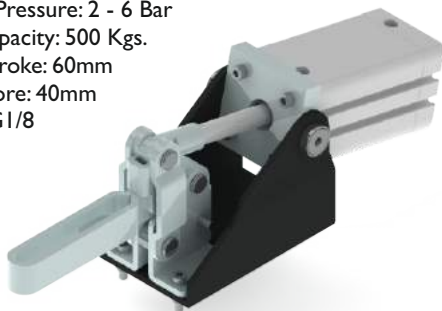

Clamp Arm Opening: 95°

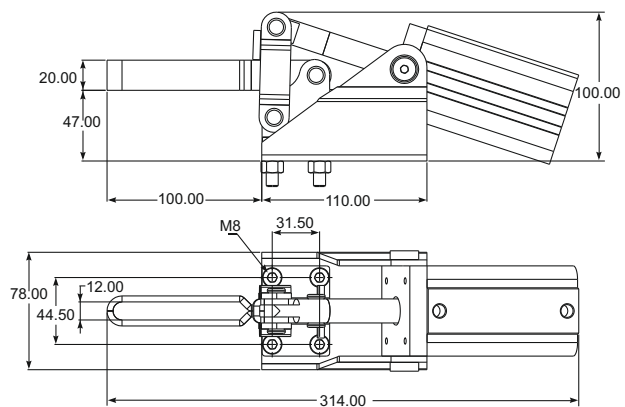

Model No: AOT - 4690 SB

Operating Pressure: 2 - 6 Bar
 Holding Capacity: 500 Kgs.
 Cylinder Stroke: 60mm
 Cylinder Bore: 40mm
 Port Size: G1/8

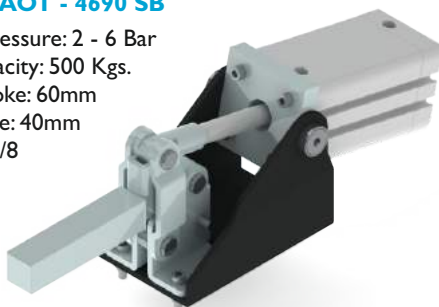

Clamp Arm Opening: 95°

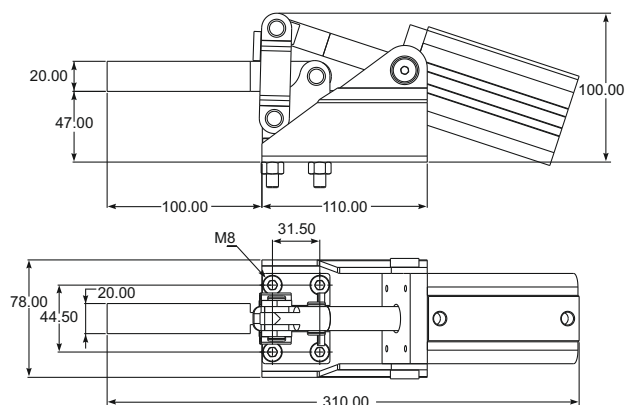

Pneumatic Clamps

Hold Down Action

Model No: AOT - 57124 UB

Operating Pressure: 2 - 6 Bar
 Holding Capacity: 750 Kgs.
 Cylinder Stroke: 100mm
 Cylinder Bore: 63mm
 Port Size: G 3/8



Clamp Arm Opening: 100°

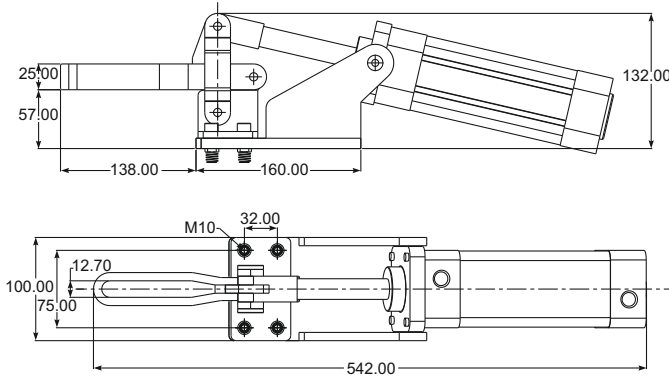

Model No: AOT - 57124 SB

Operating Pressure: 2 - 6 Bar
 Holding Capacity: 750 Kgs.
 Cylinder Stroke: 100mm
 Cylinder Bore: 63mm
 Port Size: G 3/8



Clamp Arm Opening: 100°

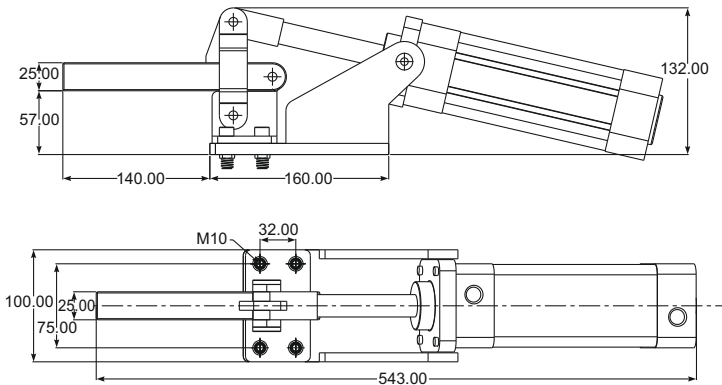

Model No: AOT - 98125 UB

Operating Pressure: 2 - 6 Bar
 Holding Capacity: 1000 Kgs.
 Cylinder Stroke: 100mm
 Cylinder Bore: 63mm
 Port Size: G 3/8



Clamp Arm Opening: 100°

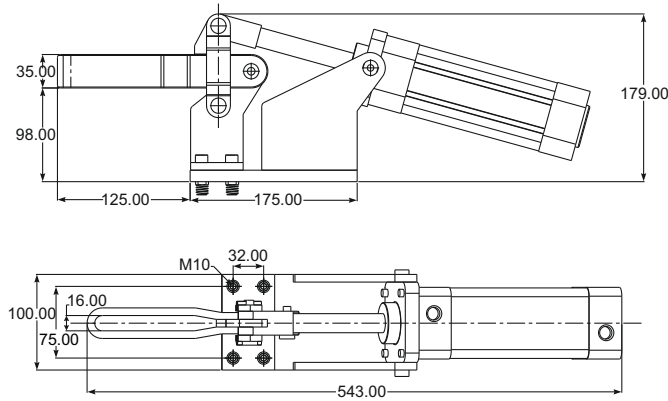

Model No: AOT - 98125 SB

Operating Pressure: 2 - 6 Bar
 Holding Capacity: 1000 Kgs.
 Cylinder Stroke: 100mm
 Cylinder Bore: 63mm
 Port Size: G 3/8

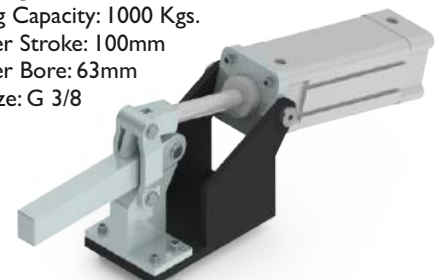

Clamp Arm Opening: 100°

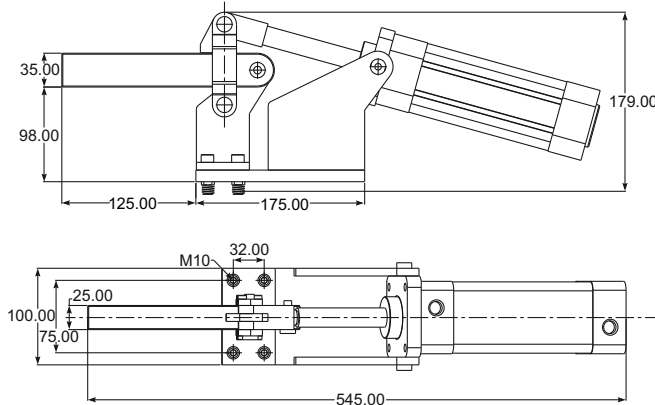

Pneumatic Clamps

Hold Down Action - Fixed Cylinder

Model No: AOT - 3565 UB/FC

Operating Pressure: 2 - 6 Bar
 Holding Capacity: 250 Kgs.
 Cylinder Stroke: 50mm
 Cylinder Bore: 25mm
 Port Size: M5

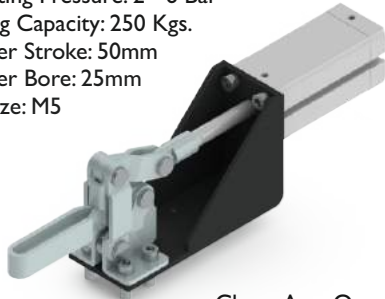

Clamp Arm Opening: 90°

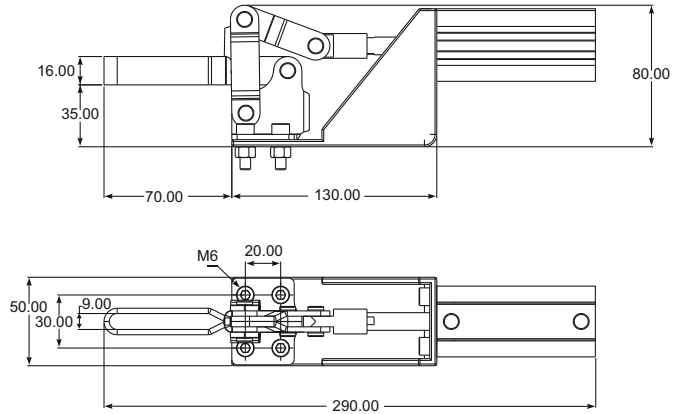

Model No: AOT - 3565 SB/FC

Operating Pressure: 2 - 6 Bar
 Holding Capacity: 250 Kgs.
 Cylinder Stroke: 50mm
 Cylinder Bore: 25mm
 Port Size: M5

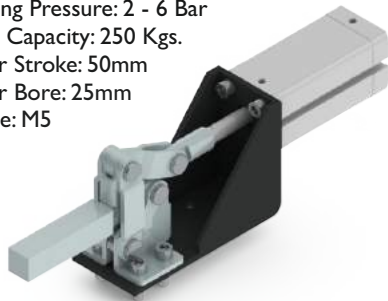

Clamp Arm Opening: 90°

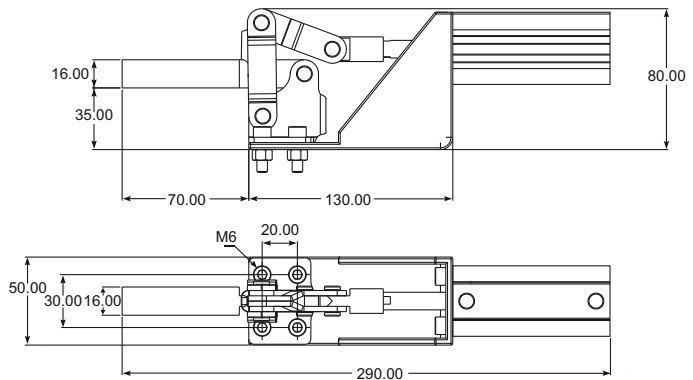

Model No: AOT - 5095 UB/FC

Operating Pressure: 2 - 6 Bar
 Holding Capacity: 500 Kgs.
 Cylinder Stroke: 80mm
 Cylinder Bore: 40mm
 Port Size: G 1/8

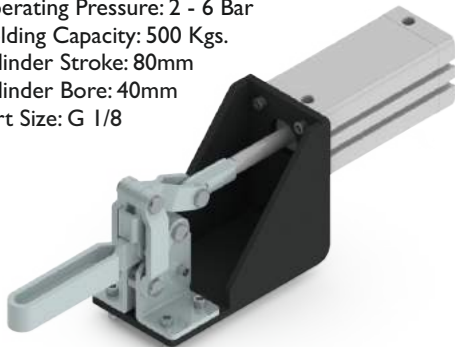

Clamp Arm Opening: 90°

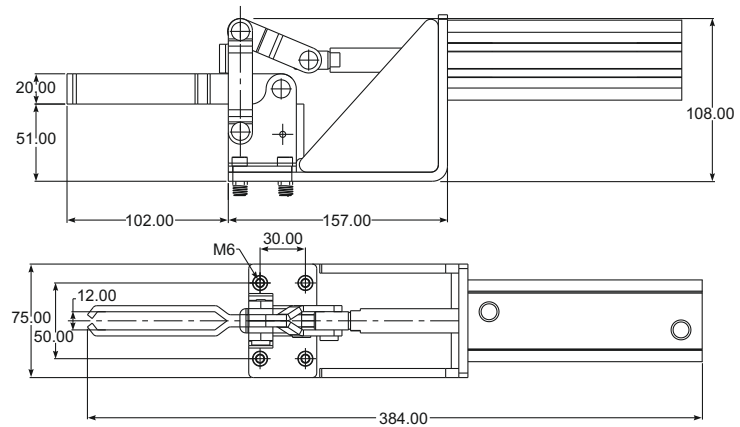

Model No: AOT - 5095 SB/FC

Operating Pressure: 2 - 6 Bar
 Holding Capacity: 500 Kgs.
 Cylinder Stroke: 80mm
 Cylinder Bore: 40mm
 Port Size: G 1/8

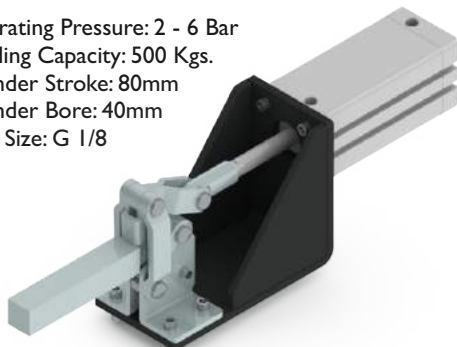

Clamp Arm Opening: 90°

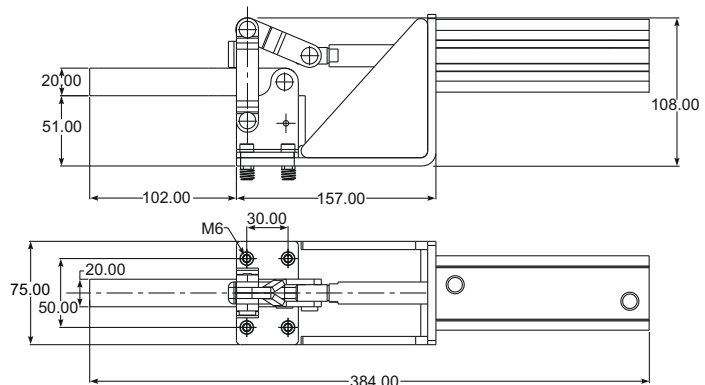

Pneumatic Clamps

Hold Down Action - Right Angle

Model No: AOT - 4085 UB / AOT - 4085 SB

Operating Pressure: 2 - 6 Bar
 Holding Capacity: 400 Kgs.
 Cylinder Stroke: 80mm
 Cylinder Bore: 40mm
 Port Size: G 1/4

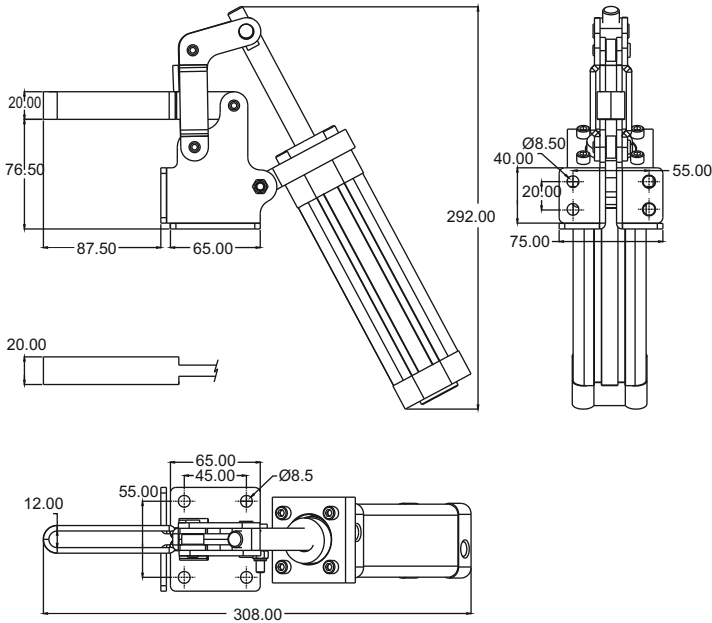

AOT - 4085 UB



AOT - 4085 SB

Clamp Arm Opening: 100°

Model No: AOT - 40125 UB / AOT - 40125 SB

Operating Pressure: 2 - 6 Bar
 Holding Capacity: 650 Kgs.
 Cylinder Stroke: 80mm
 Cylinder Bore: 40mm
 Port Size: G 1/4

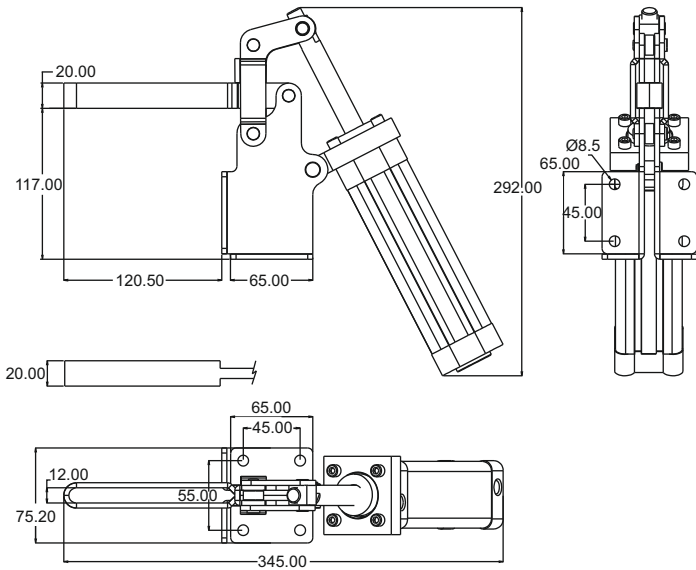

AOT - 40125 UB

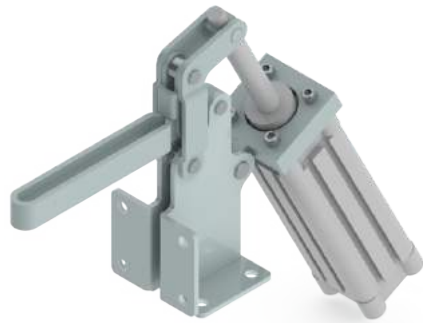

AOT - 40125 SB

Clamp Arm Opening: 100°

Pneumatic Clamps

Straight Line Action

Model No: AOT - 2530 HTC

Operating Pressure: 2 - 6 Bar
 Holding Capacity: 300 Kgs.
 Cylinder Stroke: 50mm
 Cylinder Bore: 25mm
 Port Size: M5

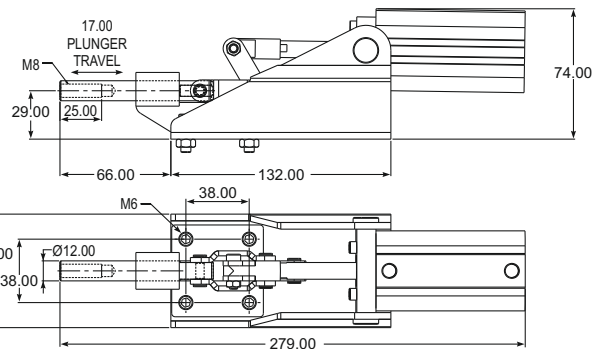

Model No: AOT - 3231 HTC

Operating Pressure: 2 - 6 Bar
 Holding Capacity: 1200 Kgs.
 Cylinder Stroke: 80mm
 Cylinder Bore: 40mm
 Port Size: G 1/4

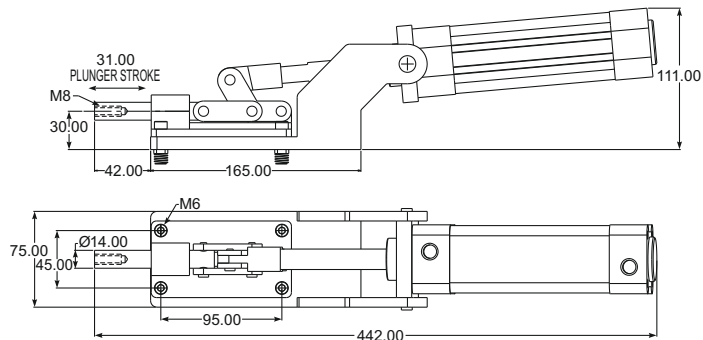

Model No: AOT - 3550 HTC

Operating Pressure: 2 - 6 Bar
 Holding Capacity: 1600 Kgs.
 Cylinder Stroke: 80mm
 Cylinder Bore: 40mm
 Port Size: G 1/4

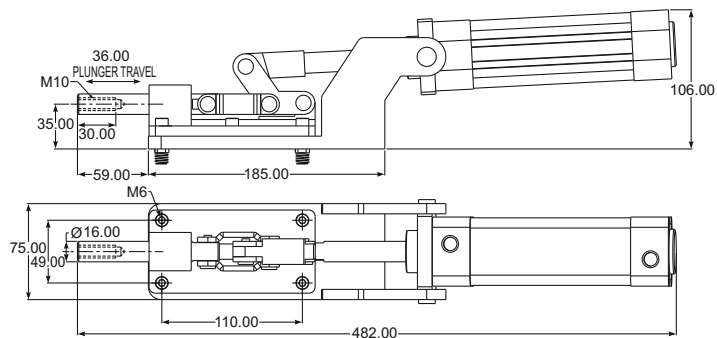

Model No: AOT - 5560 HTC

Operating Pressure: 2 - 6 Bar
 Holding Capacity: 2500 Kgs.
 Cylinder Stroke: 100mm
 Cylinder Bore: 63mm
 Port Size: G 3/8

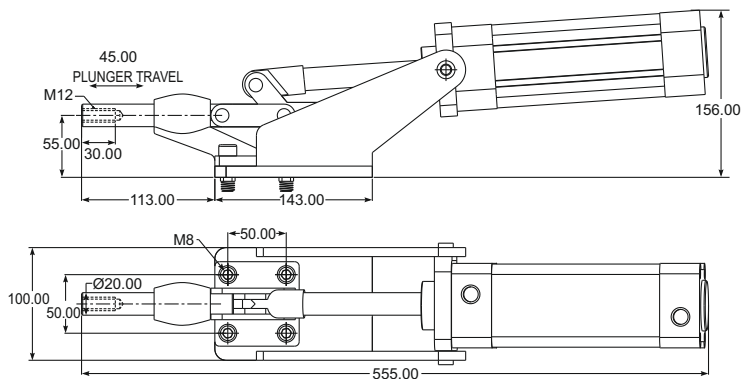

Model No: AOT - 6750 HTC

Operating Pressure: 2 - 6 Bar
 Holding Capacity: 7500 Kgs.
 Cylinder Stroke: 100mm
 Cylinder Bore: 63mm
 Port Size: G 3/8

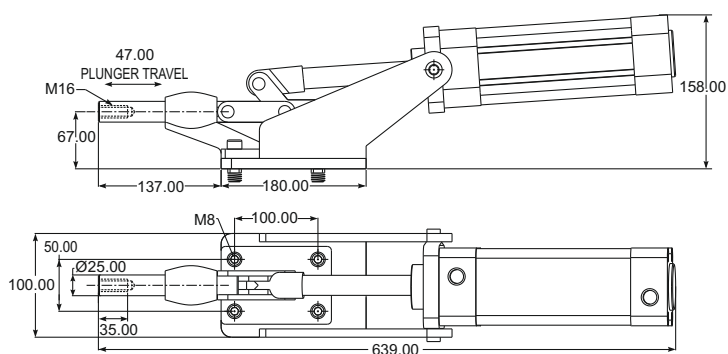

SSC Series

Model No: SSC - 1640

Operating Pressure: 2 - 6 Bar
 Holding Capacity: 250 Kgs.
 Cylinder Stroke: 40mm
 Cylinder Bore: 16mm
 Port Size: M5

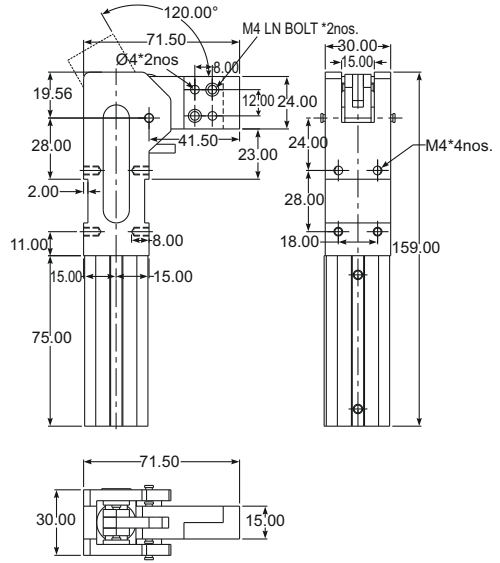
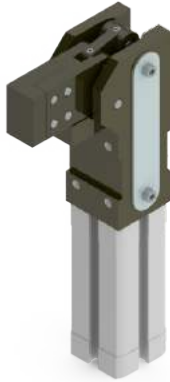

Model No: SSC - 2550

Operating Pressure: 2 - 6 Bar
 Holding Capacity: 500 Kgs.
 Cylinder Stroke: 50mm
 Cylinder Bore: 25mm
 Port Size: M5

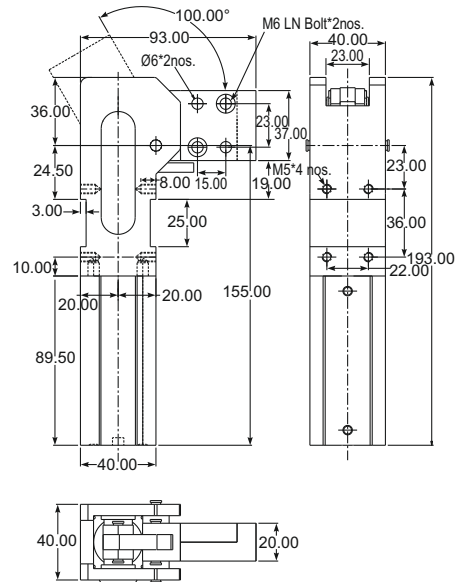
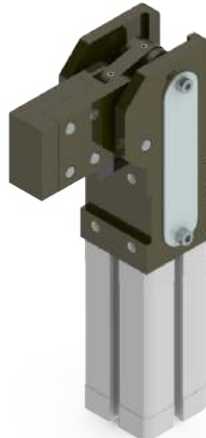

Model No: SSC - 4065

Operating Pressure: 2 - 6 Bar
 Holding Capacity: 800 Kgs.
 Cylinder Stroke: 80mm
 Cylinder Bore: 40mm
 Port Size: G 1/4

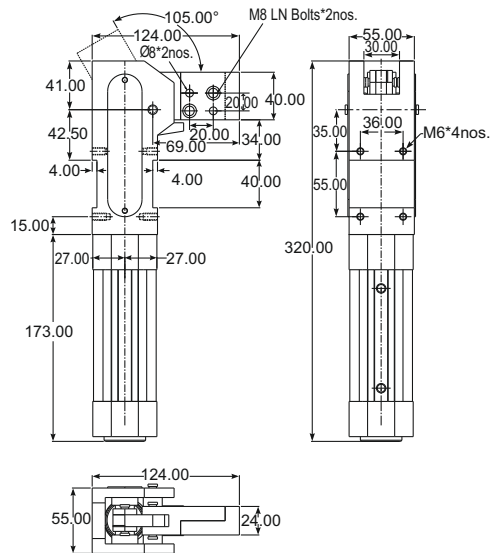
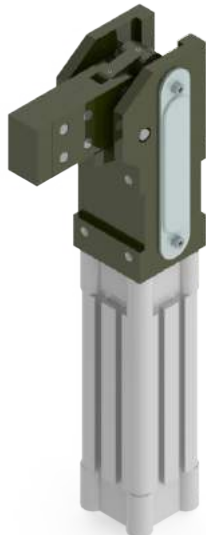

Pneumatic Clamps

SSC Series

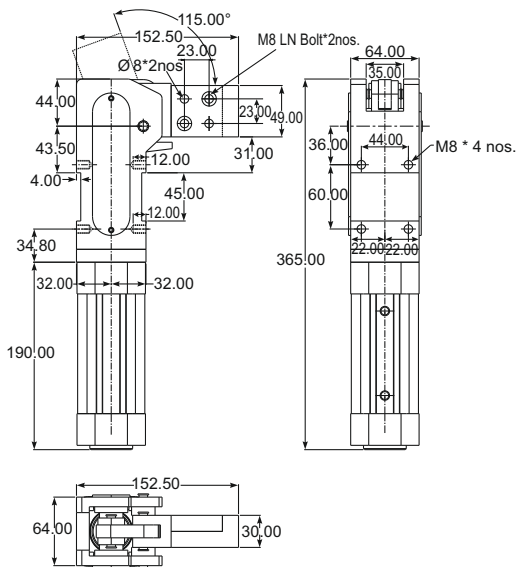

Model No: SSC - 5065

Operating Pressure: 2 - 6 Bar
 Holding Capacity: 1500 Kgs.
 Cylinder Stroke: 80mm
 Cylinder Bore: 50mm
 Port Size: G 1/4

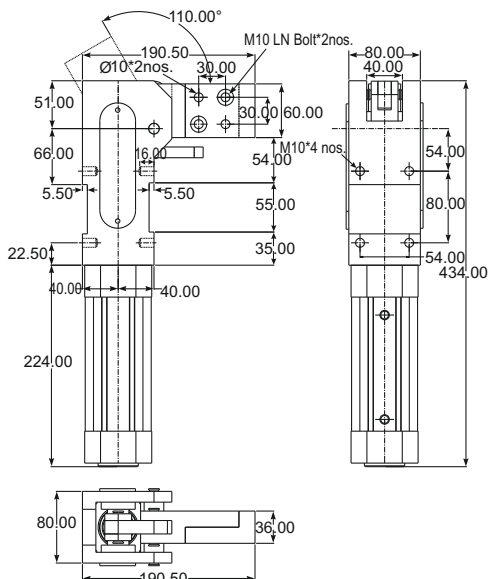

Model No: SSC - 63100

Operating Pressure: 2 - 6 Bar
 Holding Capacity: 2500 Kgs.
 Cylinder Stroke: 100mm
 Cylinder Bore: 63mm
 Port Size: G 3/8



H.V. Series

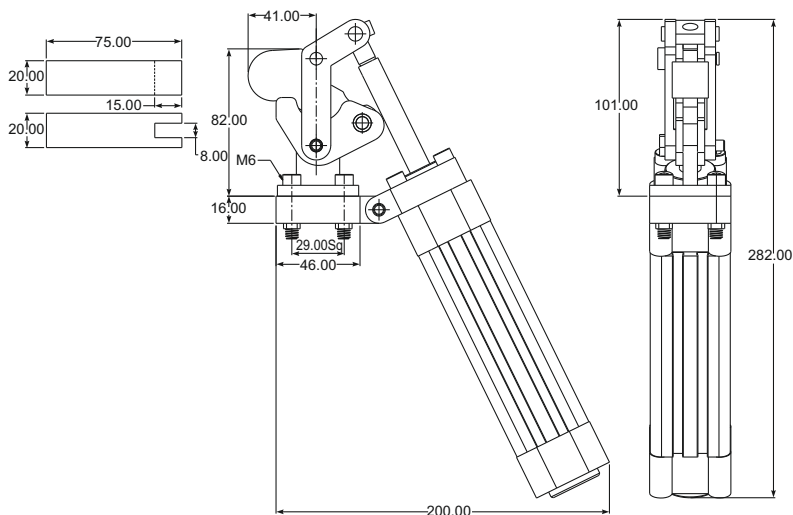

Model No: AOT - BII - 200

Operating Pressure: 2 - 6 Bar
 Holding Capacity: 200 Kgs.
 Cylinder Stroke: 80mm
 Cylinder Bore: 32mm
 Port Size: G 1/8



Clamp Arm Opening: 100°

H.V. Series

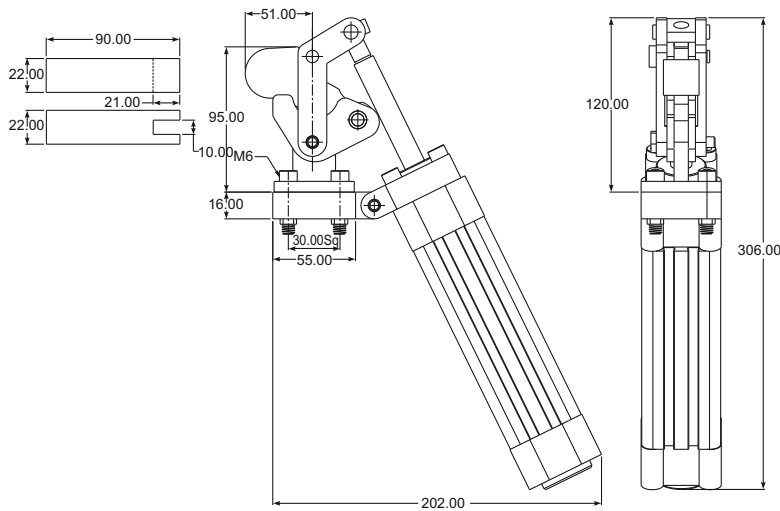

Model No: AOT - BII - 300

Operating Pressure: 2 - 6 Bar
 Holding Capacity: 300 Kgs.
 Cylinder Stroke: 80mm
 Cylinder Bore: 32mm
 Port Size: G 1/8



Clamp Arm Opening: 115°

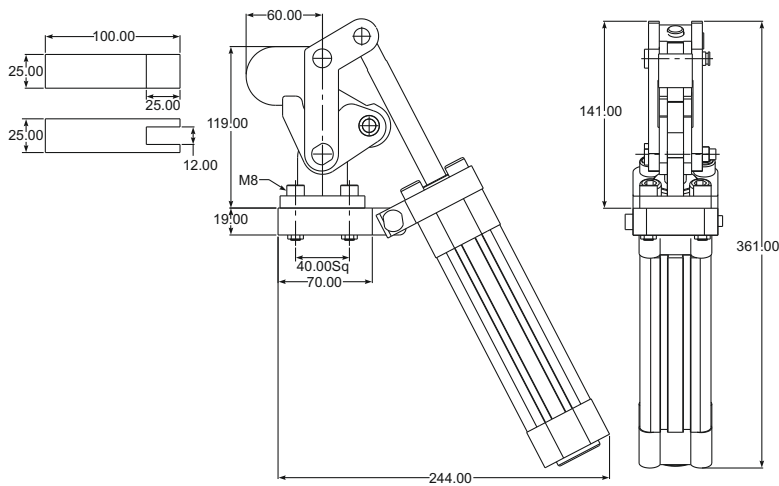

Model No: AOT - BII - 500

Operating Pressure: 2 - 6 Bar
 Holding Capacity: 750 Kgs.
 Cylinder Stroke: 100mm
 Cylinder Bore: 40mm
 Port Size: G 1/4

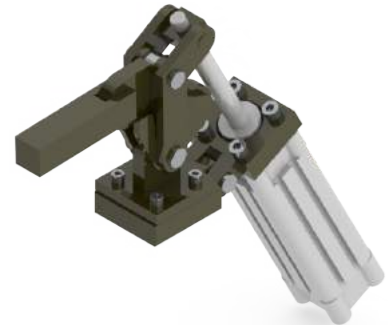

Clamp Arm Opening: 100°

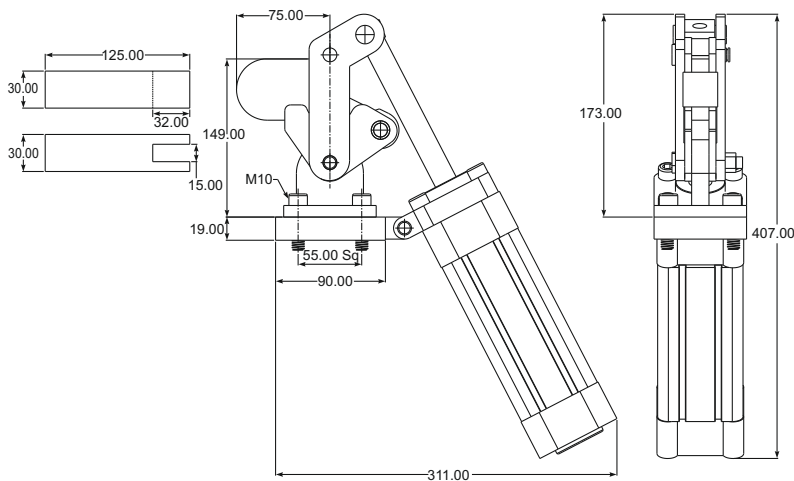

Model No: AOT - BII - 1000

Operating Pressure: 2 - 6 Bar
 Holding Capacity: 1000 Kgs.
 Cylinder Stroke: 100mm
 Cylinder Bore: 63mm
 Port Size: G 3/8

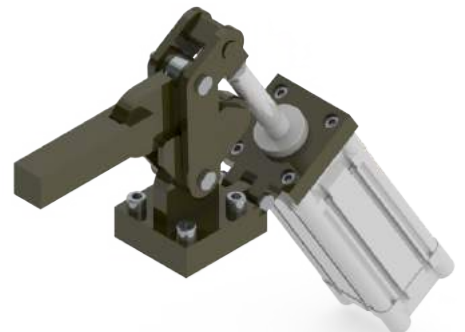

Clamp Arm Opening: 95°

Swing Clamps

Introduction

Steel-Smith introduces India's biggest range of Swing Clamps having clamping capacity range from 20 kgs. to 1600 kgs. The unique single cylinder design powers both the swing & force cycles eliminating the bulkier, two-cylinder concept that requires one cylinder for the swing motion and another cylinder for the force cycles. Gives you more force in less space with less parts. Loading and unloading of the job is very easy due to the swing action.

There are two types of Clamping Cylinders.

- Swing Action Clamps
- Link Clamps (Vertical Swing Clamps)

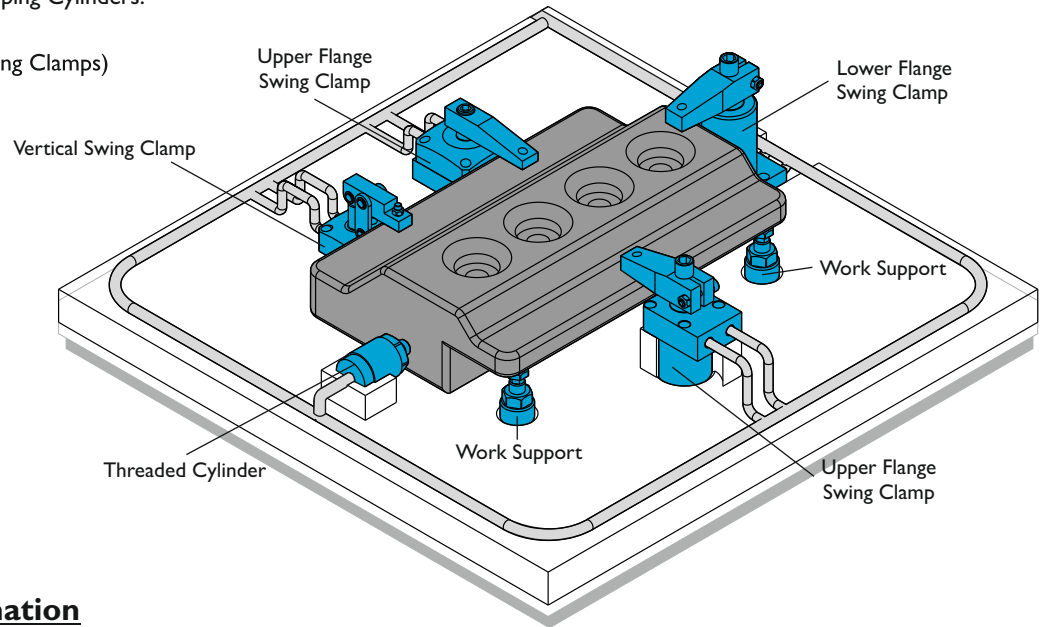

Anatomy & Information

Swing Clamps

Cross Section View of Swing Clamp

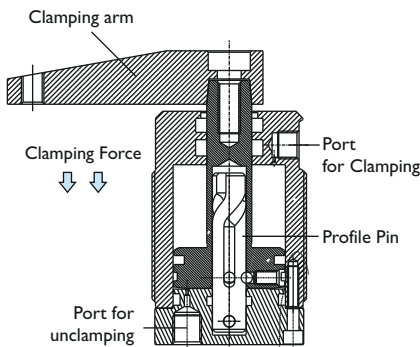

Swing Stroke / Clamp Stroke

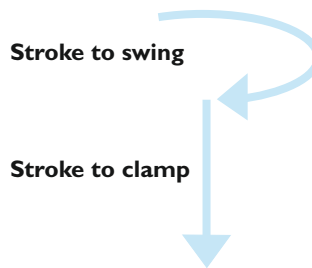

Direction of Rotation

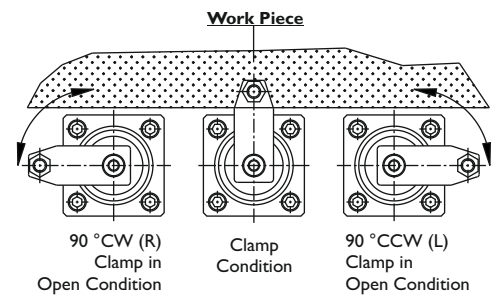

Link Clamps

Cross Section View of Link Clamp

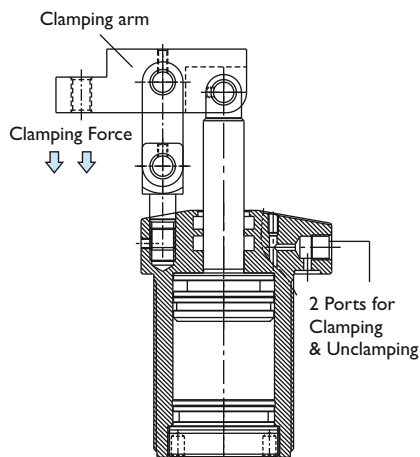

Features

In Vertical Swing clamping cylinders the clamping arm swings vertically to give the required clamping and unclamping action.

Can be used to clamp low profile work pieces.

Can produce larger clamp force than Swing Clamps in the same bore size.

Opening of Link Clamp

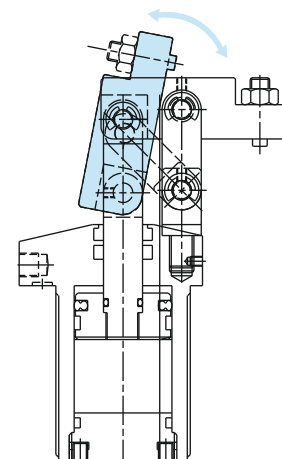

Pneumatic Swing Clamps

Pneumatic Swing Clamp - PST Series Threaded Body Model

- Body Thread for precise cylinder height positioning
- Threaded port connection
- Easy installation and removal
- Greatest flexibility in fixture design
- Available with two Flange Nuts

Material	Aluminum Alloy Body
Acting Type	Double Acting
Force	16 - 140 kgs
Stroke	28 - 30 mm
Pressure	4 - 7 Bar
Swivel Angle	90° ±2°

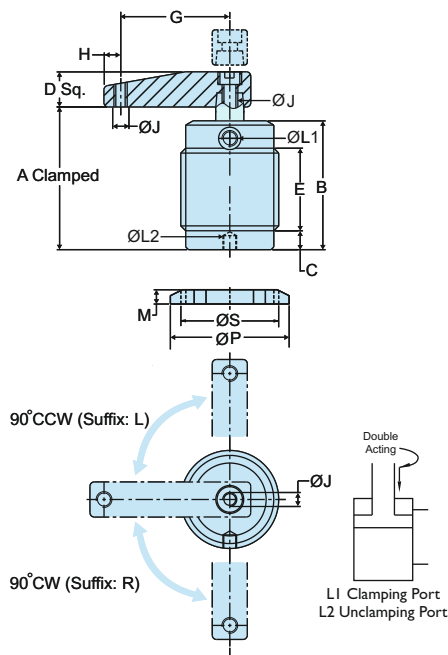

Model No.	A Clamped	B	C	D Sq.	E	G	H	J	L	M	P	S	Weight	Piston Dia.	Bore Dia.	Swing Stroke	Clamping Stroke	Force in Kgs (5 kg/cm ²)
PST-25-R/L	76	70	10	16	35	50	6	M8x1.25	M5x0.8	9	58	M40 x 1.5	0.800	14	25	14	14	16
PST-32-R/L	83	79	13	19	40	60	9	M8x1.25	G1/8	11	70	M50 x 1.5	1.100	16	32	14	16	30
PST-40-R/L	87	83	13	19	45	70	9	M8x1.25	G1/8	11	75	M55 x 1.5	1.250	16	40	14	15	50
PST-50-R/L	92	87	13	25	50	80	10	M12x1.5	G1/8	12	85	M65 x 1.5	1.700	20	50	14	14	85
PST-63-R/L	97	92	13	25	56	90	10	M12x1.5	G1/8	15	105	M80 x 1.5	2.200	20	63	15	15	140

Pneumatic Swing Clamp - PSF Series Lower Flange Version

- No Fixture hole required
- Cylinder can be bolted directly to the fixture
- Easiest mounting preparation in the swing clamp line
- Square flange design enables clamping at all four sides of the clamp
- Allows extra large parts to be clamped

Material	Aluminum Alloy Body
Acting Type	Double Acting
Force	16 - 140 kgs
Stroke	26 - 29 mm
Pressure	4 - 7 Bar
Swivel Angle	90° ±2°

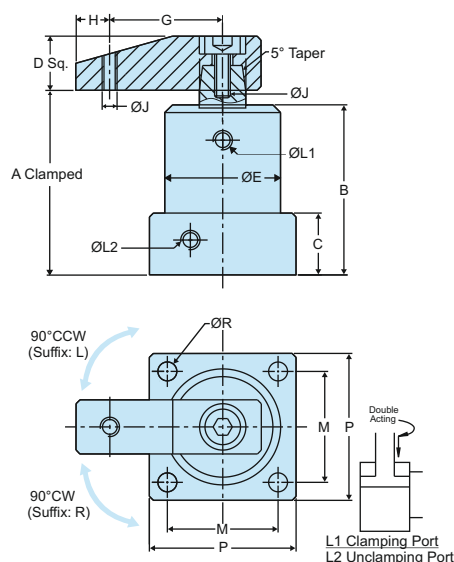

Model No.	A Clamped	B	C	D Sq.	E	G	H	J	L	M	P	R	Weight	Piston Dia.	Bore Dia.	Swing Stroke	Clamping Stroke	Force in Kgs (5 kg/cm ²)
PSF-25-R/L	69.5	65.5	23	16	35	30	8	M8 x 1.25	M5 x 0.8	30	40	4.5	0.400	14	25	12	14	16
PSF-32-R/L	76.5	71	23	19	50	50	9	M8 x 1.25	1/8 PT	44	54	6.5	0.700	16	32	12	14	30
PSF-40-R/L	79	75	26	19	55	50	9	M8 x 1.25	1/8 PT	48	58	6.5	0.850	16	40	12	15	50
PSF-50-R/L	84	80	26	25.4	65	70	10	M10 x 1.5	1/8 PT	55	68	8.5	1.300	20	50	14	15	85
PSF-63-R/L	90	86	30	25.4	75	70	10	M10 x 1.5	1/8 PT	64	80	8.5	1.800	20	63	14	15	140

Pneumatic Swing Clamps

Pneumatic Swing Clamp - NPSU Series Upper Flange Version

- No Fixture hole required
- Cylinder can be bolted directly to the fixture
- Easiest mounting preparation in the swing clamp line
- Square flange design enables clamping at all four sides of the clamp
- Allows extra large parts to be clamped

Material	Aluminum Alloy Body
Acting Type	Double Acting
Force	16 - 140 kgs
Stroke	27 - 32 mm
Pressure	4 - 7 Bar
Swivel Angle	90° ±2°

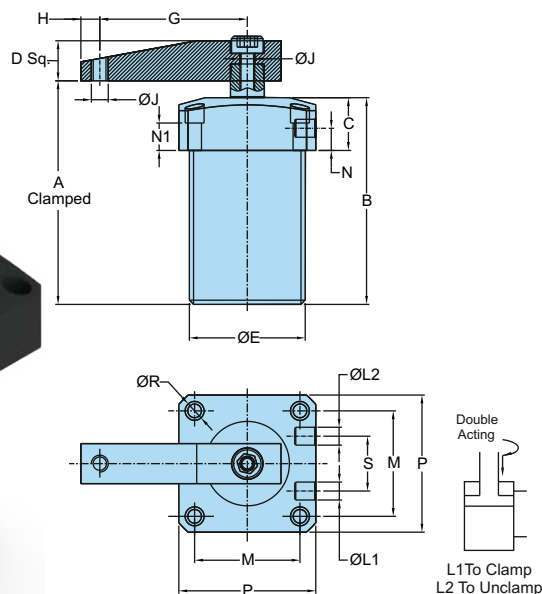

Model No.	A Unclamp	B	C	D Sq.	E	G	H	J	L	M	N	N1	P	R	S	Weight	Piston Dia.	Bore Dia.	Swing Stroke	Clamping Stroke	Force in Kgs (5 kg/cm ²)
NPSU-25-R/L	92	87	25	16	M40 x 1.5	50	6	M6	M5	37	11.5	14.5	50	5.5	23	0.700	14	25	13	14	16
NPSU-32-R/L	103	98	25	19	M50 x 1.5	60	9	M8	G1/8	45	10.5	13	60	6.5	23	0.800	16	32	16	14	30
NPSU-40-R/L	103	98	25	19	M55 x 1.5	70	9	M8	G1/8	50	10.5	13	65	6.5	26	0.850	16	40	15	15	50
NPSU-50-R/L	110	105	25	25	M65 x 1.5	80	10	M12	G1/8	58	10.5	11	75	8.5	32	1.000	20	50	17	15	80
NPSU-63-R/L	110	105	25	25	M80 x 1.5	90	10	M12	G1/8	70	10.5	11	90	8.5	35	1.200	20	63	15	15	140

Pneumatic Swing Clamp - PSB Series Block Version

- Block Design permits the clamp to be mounted from three different faces
- Grooves on one side for Reed switch mounting
- Simple mounting preparation and easy installation 2 or 4 mounting bolts

Material	Aluminum Alloy Body
Acting Type	Double Acting
Force	16 - 140 kgs
Stroke	27 - 32 mm
Pressure	4 - 7 Bar
Swivel Angle	90° ±2°

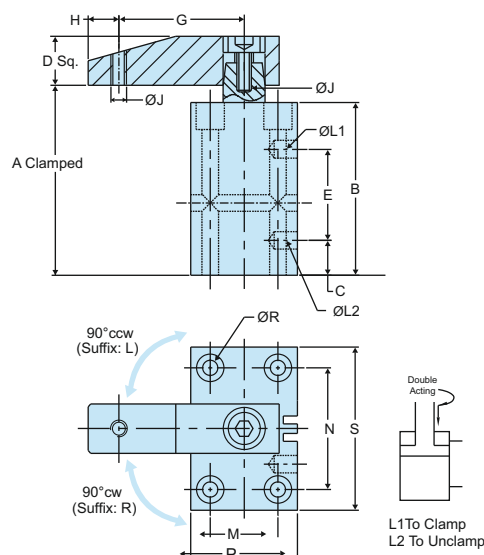

Model No.	A Clamped	B	C	D Sq.	E	G	H	J	L	M	N	P	R	S	Weight	Piston Dia.	Bore Dia.	Swing Stroke	Clamping Stroke	Force in Kgs (5 kg/cm ²)
PSB-25-R/L	82	78	21	16	34.5	50	6	M6 x 1.00	M5 x 0.8	20	40	35	6.5	55	0.700	14	25	13	14	16
PSB-32-R/L	96	90	21	19	51.5	60	9	M8 x 1.25	G 1/8"	30	45	45	6.5	60	0.900	16	32	16	14	30
PSB-40-R/L	96	90	22	19	50.5	70	9	M8 x 1.25	G 1/8"	37	52	55	8.5	70	1.100	16	40	15	15	50
PSB-50-R/L	105	100	25	25	53.5	80	10	M12 x 1.5	G 1/8"	46	66	65	8.5	85	1.200	20	50	17	15	80
PSB-63-R/L	107	100	28	25	52	90	10	M12 x 1.5	G 1/8"	60	80	80	10.5	100	1.400	20	63	15	15	140

Hydraulic Swing Clamps

Hydraulic Swing Clamp - HST Series Threaded Body

- Body Thread for precise cylinder height positioning
- Threaded port connection
- Easy installation and removal
- Greatest flexibility in fixture design
- Available with two Flange Nuts

Material	Aluminum Alloy Body
Acting Type	Double Acting
Force	59 - 400 kgs
Stroke	26 - 29 mm
Pressure	20 - 70 Bar
Swivel Angle	90° ±2°

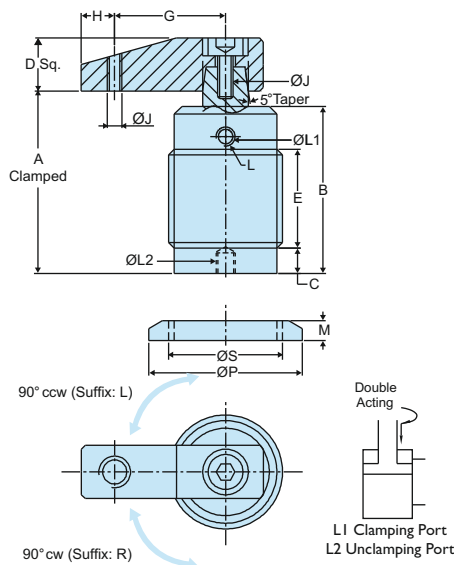

Model No.	A Clamped	B	C	D	E	G	H	J	L	M	P	S	Weight	Piston Dia.	Bore Dia.	Swing Stroke	Clamping Stroke	Force in Kgs (25 kg/cm ²)
HST-25-R/L	74	70	9	25.4	35	50	10	M10 x 1.5	1/8 PT	10	65	M45 x 1.5	0.800	18	25	12	14	59
HST-32-R/L	82	76	9	25.4	45	55	10	M10 x 1.5	1/8 PT	11	70	M50 x 1.5	1.100	20	32	14	15	125
HST-40-R/L	84.6	80	9	25.4	45	55	10	M10 x 1.5	1/8 PT	11	75	M55 x 1.5	1.250	20	40	14	15	200
HST-50-R/L	92	87	9	25.4	50	55	10	M10 x 1.5	1/8 PT	12	85	M65 x 1.5	1.700	20	50	14	14	400

Hydraulic Swing Clamp - HSF Series Lower Flange Version

- No Fixture hole required
- Cylinder can be bolted directly to the fixture
- Easiest mounting preparation in the swing clamp line
- Square flange design enables clamping at all four sides of the clamp
- Allows extra large parts to be clamped

Material	Aluminum Alloy Body
Acting Type	Double Acting
Force	59 - 600 kgs
Stroke	26 - 29 mm
Pressure	20 - 70 Bar
Swivel Angle	90° ±2°

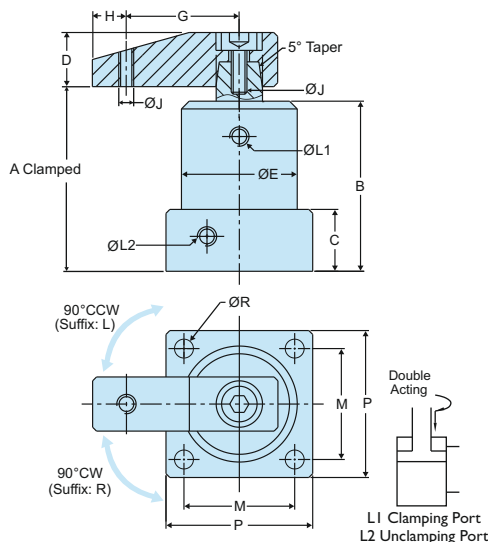

Model No.	A Clamped	B	C	D Sq.	E	G	H	J	L	M	P	R	Weight	Piston Dia.	Bore Dia.	Swing Stroke	Clamping Stroke	Force in kgs (25 kg/cm ²)
HSF-25-R/L	74	70	23	25.4	45	50	10	M10 x 1.5	1/8 PT	40	50	6.5	0.800	18	25	12	14	59
HSF-32-R/L	82	76	25	25.4	50	55	10	M10 x 1.5	1/8 PT	44	55	6.5	1.000	20	32	14	15	125
HSF-40-R/L	84.6	80	27	25.4	54	55	10	M10 x 1.5	1/8 PT	48	62	8.5	1.100	20	40	14	15	200
HSF-50-R/L	85.5	80	27	25.4	65	55	10	M10 x 1.5	1/8 PT	57	74	8.5	1.400	20	50	14	15	400
HSF-63-R/L	89	85	32	32	80	75	11	M12 x 1.75	1/8 PT	70	88	10.5	2.300	25	63	14	15	600

Hydraulic Swing Clamps

Hydraulic Swing Clamp - NFT Series Threaded Body Model

- Body Thread for precise cylinder height positioning
- Threaded port connection
- Easy installation and removal
- Greatest flexibility in fixture design
- Available with two Flange Nuts

For Single Acting clamp the Normal Condition will be Un-clamped condition.

Material	Medium Carbon Steel Body
Acting Type	Single Acting / Double Acting
Force	495 - 1600 kgs
Stroke	23 - 33 mm
Pressure	50 - 350 Bar
Swivel Angle	90° ±2°

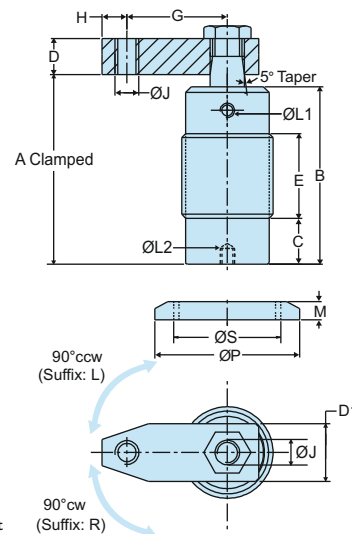

Model No.	A Clamped	B	C	D	E	G	H	J	L	M	P	S	Weight	Piston Dia.	Bore Dia.	Swing Stroke	Clamping Stroke	Force in Kgs (210 kg/cm ²)
Single Acting																		
NFT-25-A-R/L	108	102	18	19	48	45	10	M12	1/8 PT	10	65	M45 x 1.5	1.800	18	25	12	11	495
NFT-32-A-R/L	105	97	18	19	52	50	10	M12	1/8 PT	11	70	M50 x 1.5	2.100	22	32	12	11	890
NFT-40-A-R/L	105	98	18	19	54	50	10	M12	1/8 PT	11	80	M60 x 1.5	2.200	25	40	12	11	1600
Double Acting																		
NFT-25-B-R/L	103	102	18	19	48	45	10	M12	1/8 PT	10	65	M45 x 1.5	1.800	18	25	15	18	495
NFT-32-B-R/L	103	97	18	19	52	50	10	M12	1/8 PT	11	70	M50 x 1.5	2.100	22	32	15	18	890
NFT-40-B-R/L	103	98	18	19	54	50	10	M12	1/8 PT	11	80	M60 x 1.5	2.200	25	40	15	18	1600

Hydraulic Swing Clamp - NFS Series Lower Flange Version

- No Fixture hole required
- Cylinder can be bolted directly to the fixture
- Flexible design allows for manifold or threaded port connection
- Easiest mounting preparation in the swing clamp line
- Square flange design enables clamping at all four sides of the clamp
- Allows extra large parts to be clamped

For Single Acting clamp the Normal Condition will be Un-clamped condition.

Material	Medium Carbon Steel Body
Acting Type	Single Acting / Double Acting
Force	495 - 1600 kgs
Stroke	23 - 33 mm
Pressure	50 - 350 Bar
Swivel Angle	90° ±2°

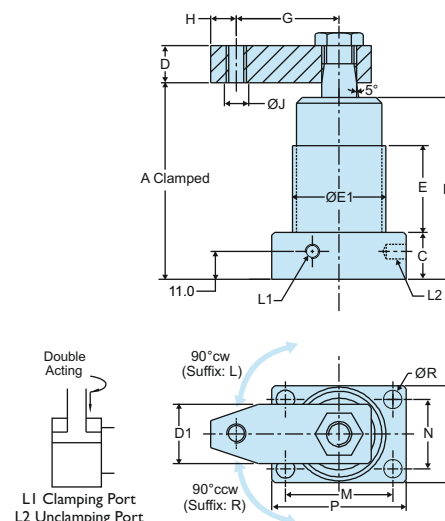

Model No.	A Clamped	B	C	D	E	E1	G	H	J	L	M	N	P	R	S	Weight	Piston Dia.	Bore Dia.	Swing Stroke	Clamping Stroke	Force in Kgs (210 kg/cm ²)
Single Acting																					
NFS-25-A-R/L	112	106	22	19	48	M45 x 1.5	45	10	M12	1/8 PT	50	30	64	6.5	46	1.600	18	25	12	11	495
NFS-32-A-R/L	109	101	22	19	52	M50 x 1.5	50	10	M12	1/8 PT	54	34	68	8.5	54	1.800	22	32	12	11	890
NFS-40-A-R/L	109	102	22	19	54	M60 x 1.5	50	10	M12	1/8 PT	66	40	84	8.5	64	2.800	25	40	12	11	1600
Double Acting																					
NFS-25-B-R/L	107	106	22	19	48	M45 x 1.5	45	10	M12	1/8 PT	50	30	64	6.5	46	1.400	18	25	15	18	495
NFS-32-B-R/L	107	101	22	19	52	M50 x 1.5	50	10	M12	1/8 PT	54	34	68	8.5	54	1.700	22	32	15	18	890
NFS-40-B-R/L	107	102	22	19	54	M60 x 1.5	50	10	M12	1/8 PT	66	40	84	8.5	64	2.700	25	40	15	18	1600

Link Clamps

Pneumatic Link Clamps - PLCU Series Upper Flanged Version

- Cylinder can be bolted directly to the fixture
- Square flange design enables clamping at all four sides of the clamp
- Allows extra large parts to be clamped

Material	Aluminum Alloy Body
Acting Type	Double Acting
Force	34 - 218 kgs
Pressure	4 - 7 Bar

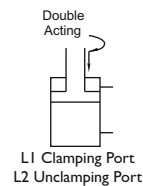
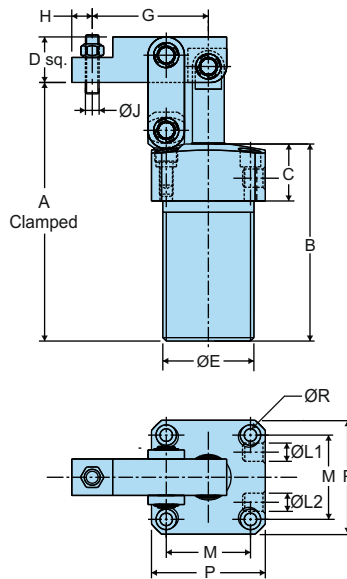

Model No.	A Clamped	B	C	D	E	G	H	J	L	M	P	R	Weight	Piston Dia.	Bore Dia.	Stroke	Force in Kgs (7 kg/cm ²)
PLCU-25	111.5	86.5	25	17	M40 x 1.5	41	7	M6x1.0	M5x0.8	37	50	5.5	0.600	14	25	22	34
PLCU-32	129.5	97.5	25	20	M50 x 1.5	52	8	M8x1.25	G1/8	45	60	6.5	1.000	16	32	28	56
PLCU-40	132.5	97.5	25	25	M55 x 1.5	56	10	M8x1.25	G1/8	50	65	6.5	1.200	16	40	30	88
PLCU-50	144	104	25	30	M65 x 1.5	63.5	14	M12x1.75	G1/8	58	75	8.5	2.000	20	50	30	137
PLCU-63	149	105	25	30	M80 x 1.5	74	14	M12x1.75	G1/8	70	90	8.5	2.700	20	63	30	218

Hydraulic Link Clamp - LHC01D Series - Upper Flange Version

- Cylinder can be bolted directly to the fixture
- Square flange design enables clamping at all four sides of the clamp
- Allows extra large parts to be clamped

Material	S45C Body
Acting Type	Double Acting
Force	122 - 780 kgs
Pressure	20 - 70 Bar

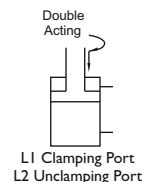
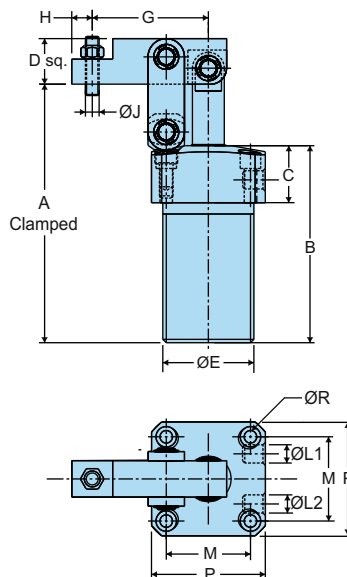

Model No.	A Clamped	B	C	D	E	G	H	J	L	M	P	R	Weight	Piston Dia.	Bore Dia.	Stroke	Force in Kgs (70 kg/cm ²)
LHC01D-25	111.5	86.5	25	17	M40 x 1.5	41	7	M6x1.0	1/8 PT	37	50	5.5	1.200	14	25	22	122
LHC01D-32	129	97	25	20	M50 x 1.5	52	8	M8x1.25	1/8 PT	45	60	6.5	1.800	16	32	28	201
LHC01D-40	132	97	25	25	M55 x 1.5	56	10	M8x1.25	1/8 PT	50	65	6.5	2.500	16	40	30	315
LHC01D-50	144	104	25	30	M65 x 1.5	63.5	14	M12x1.75	1/8 PT	58	75	8.5	4.000	20	50	30	490
LHC01D-63	149	105	25	30	M80 x 1.5	74	14	M12x1.75	1/8 PT	70	90	8.5	6.500	20	63	30	780

Any Tools Needed? No Need!

Just Turn the Handle!



ONE-TOUCH CLAMPS

for Better Efficiency and Lower Costs



Quick Manual Clamping with No Tools

Imao One-Touch Clamps allow clamping and unclamping the workpiece just by turning the handle, without any tools. This one-touch feature helps to slash workpiece loading/unloading time, for drastic setup time reduction and increased productivity.

One-Touch Clamps serve for various applications in machining, assembly, testing and inspection, in different industries.



QLSWC - Swing Clamps (Mini)



(Black Oxide Finish)

(Electroless Nickel Plated)

On Request



Type	Body/Handle/Clamping Spindle	Arm	Cam Shaft	Knob
QLSWC	Steel (S 4 5 C) Quenched and tempered Black oxide finish	SCM 4 4 0 Quenched and tempered Black oxide finish	SCM 4 1 5 Quenched and tempered Black oxide finish	Phenolic plastic Black
QLSWC-NP	S 4 5 C Quenched and tempered Electroless nickel plated	SCM 4 4 0 Quenched and tempered Electroless nickel plated	SCM 4 1 5 Quenched and tempered Electroless nickel plated	

Counterclockwise Clamping

Clockwise Clamping

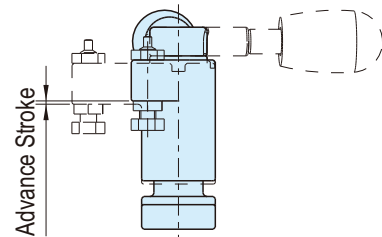
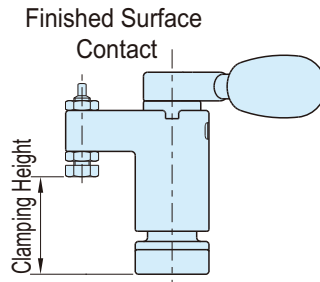
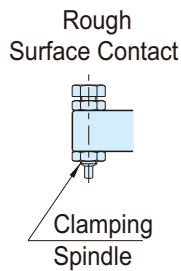
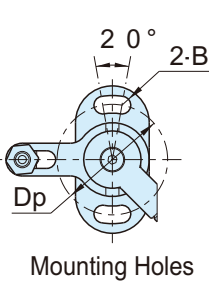
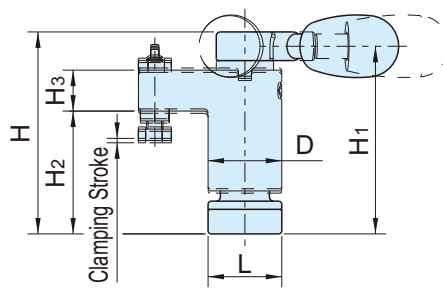
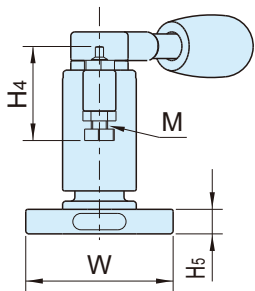
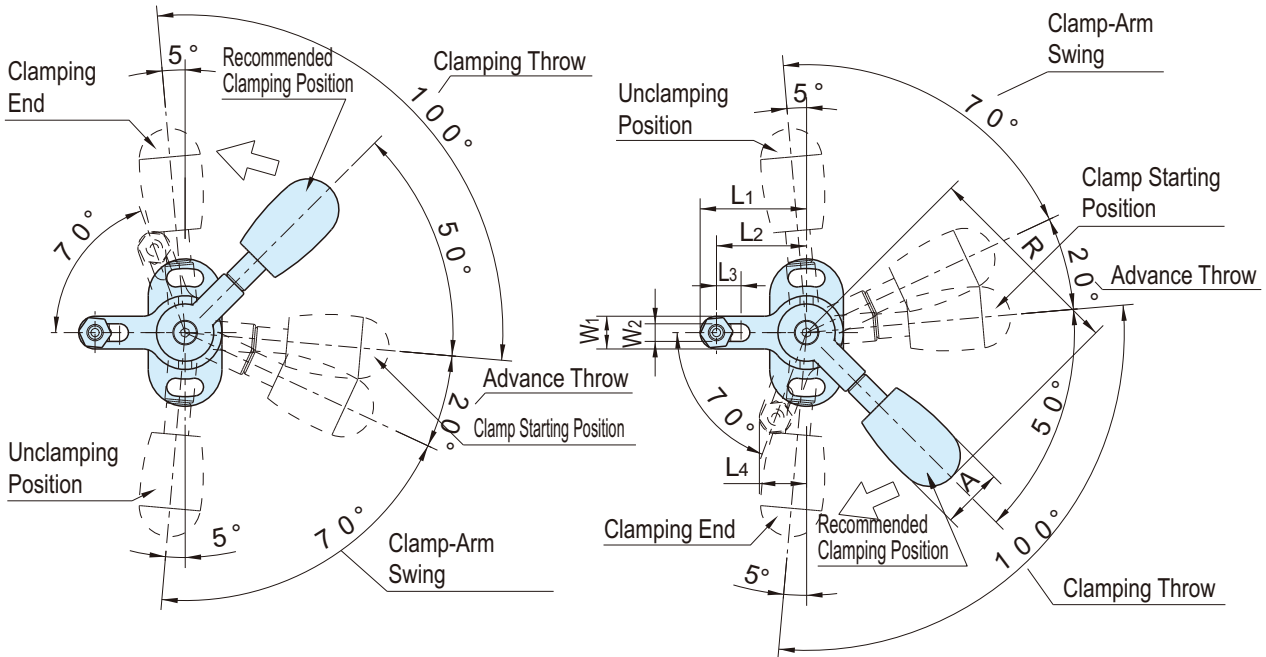

QLSWC - Swing Clamps (Mini)

Clamping Direction

Part Number		Clamping Height *)				Clamping Stroke	Advance Stroke	L ₂	L ₃	L ₁	L ₄	W	L	H ₅	B
		Finished Surface Contact		Rough Surface Contact											
		Min.	Max.	Min.	Max.										
QLSWC100R	CW	22.8	24.8	22.4	24.4	1	0.8	22	6	26	11.5	36	18	6	4.3
QLSWC100L	CCW	(22.3~23.3)	(24.3~25.3)	(21.9~22.9)	(23.9~24.9)										
QLSWC150R	CW	31.3	33.3	32.2	34.2	1.4	1.1	30		35	15.3	45	23	8	5.3
QLSWC150L	CCW	(30.6~32)	(32.6~34)	(31.5~32.9)	(33.5~34.9)										
QLSWC200R	CW	32.5	39	33.5	40	1.5	1.4	37	8	45	20.7	65	30	12	8.4
QLSWC200L	CCW	(31.7~33.2)	(38.2~39.7)	(32.7~34.2)	(39.2~40.7)										
QLSWC300R	CW	36.5	46	39	48.5	1.9	1.7	45		55	25.4	85	40	15	10.5
QLSWC300L	CCW	(35.5~37.4)	(45~46.9)	(38~39.9)	(47.5~49.4)										

Part Number	Dp	H	D	W ₁	W ₂	H ₃	H ₂	M	H ₄	R	A	H ₁	Allowable Operating Load (N)**	Clamping Force (N)	Clamping Mechanism
QLSWC100R	27	49	18	8	4.3	10	30	M 4×0.7	22.8	50	15	45.8	100	1,100	Spiral Cam Cam Angle:5°
QLSWC100L															
QLSWC150R	34	66	23	10	5.3	14	40	M 5×0.8	28.5	63	20	61.3	150	1,800	
QLSWC150L															
QLSWC200R	48	82	30	16	8.4	18	50	M 8×1.25	45.5	80	26	76.5	200	2,200	Spiral Cam Cam Angle:4°
QLSWC200L															
QLSWC300R	64	100	40	20	10.4	22	60	M10×1.5	57	100	33	93	300	3,500	
QLSWC300L															

QLSWC (Black oxide finish) **QLSWC-NP** (Electroless nickel) On Request

Part Number	Weight (g)	Part Number	Weight (g)
QLSWC100R	112	QLSWC100R-NP	112
QLSWC100L		QLSWC100L-NP	
QLSWC150R	250	QLSWC150R-NP	250
QLSWC150L		QLSWC150L-NP	
QLSWC200R	570	QLSWC200R-NP	570
QLSWC200L		QLSWC200L-NP	
QLSWC300R	1,200	QLSWC300R-NP	1,200
QLSWC300L		QLSWC300L-NP	

*) Clamping height can be adjusted. The parenthesised values denote clamping height range.
**) Allowable load to operate the handle.

Technical Information

Allowable Loads in Machining of Workpiece Bottom Ensure that any force more than stated below is not applied.

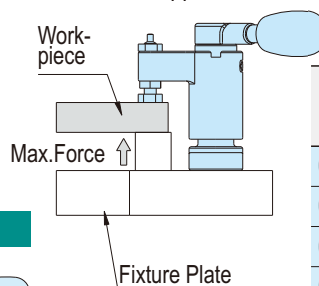

Series	Allowable Force To Workpiece Bottom (Per Clamp)
QLSWC100	max.2 ,300N
QLSWC150	max.3 ,600N
QLSWC200	max.3 ,700N
QLSWC300	max.5 ,600N

How To Use

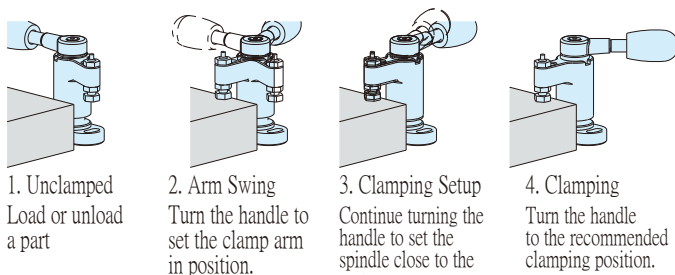

How To Change Handle Position

The dodecagonal socket in the hub of the handle allows changing the handle position by 30°.

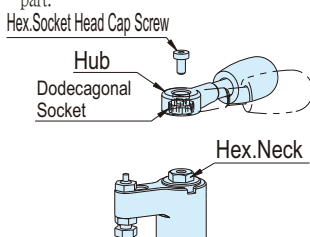

Performance Curve

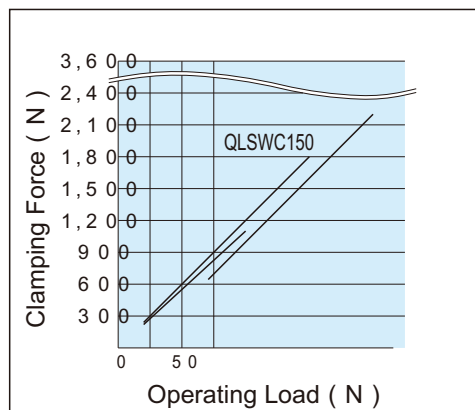

QLSWC - Swing Clamps (Mini) with Cam Handle



(Black Oxide Finish)



(Electroless Nickel Plated)

On Request

Style	Body/Washer/Clamping Spindle	Arm/Handle
QLSWC	Steel (S 4 5 C) Quenched and tempered Black oxide finish	Steel (SCM 4 4 0) Quenched and tempered Black oxide finish
QLSWC-NP	Steel (S 4 5 C) Quenched and tempered Electroless nickel plated	Steel (SCM 4 4 0) Quenched and tempered Electroless nickel plated

Counterclockwise Clamping

Clockwise Clamping

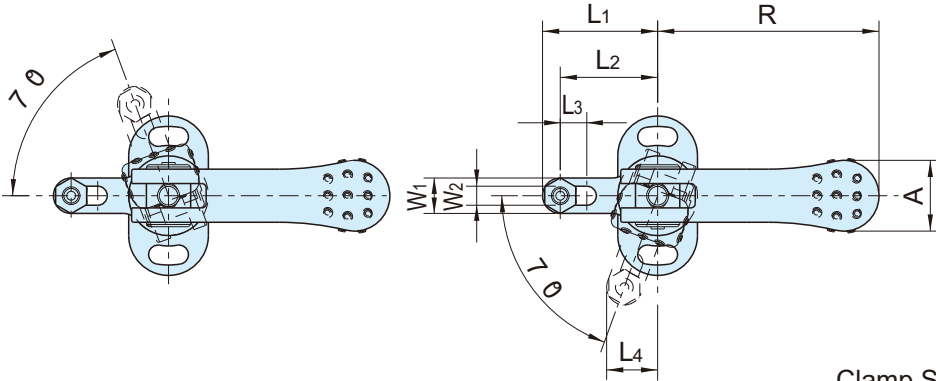

Clamp Starting Position

Recommended Clamping Position

Clamping End

Unclamping Position

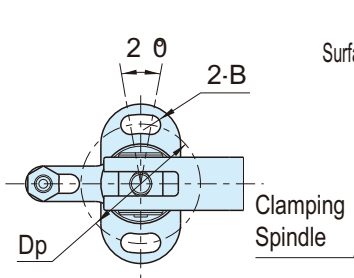
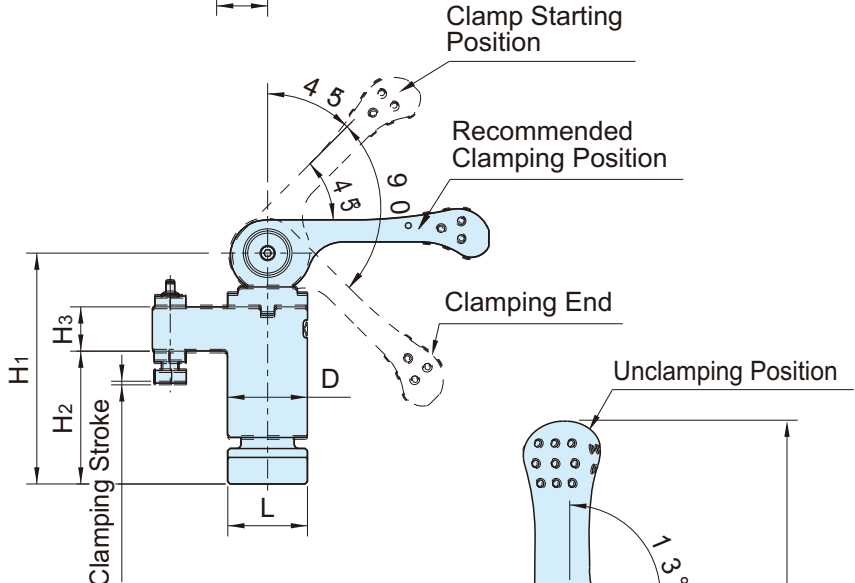
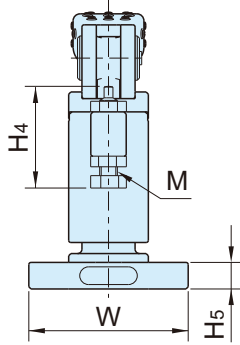

Mounting Holes

QLSWC - Swing Clamps (Mini) with Cam Handle

Part Number	Clamping Direction	Clamping Height *)				Clamping Stroke	Overall Stroke	L ₂	L ₃	L ₁	L ₄	W	L	H ₅	B
		Finished Surface Contact		Rough Surface Contact											
		Min.	Max.	Min.	Max.										
QLSWC100VR	CW	22.8	24.8	22.4	24.4	0.8	1.2	22	6	26	11.5	36	18	6	4.3
QLSWC100VL	CCW	(22.4~23.2)	(24.4~25.2)	(22~22.8)	(24~24.8)										
QLSWC150VR	CW	31.3	33.3	32.2	34.2	1	1.5	30	8	35	15.3	45	23	8	5.3
QLSWC150VL	CCW	(30.8~31.8)	(32.8~33.8)	(31.7~32.7)	(33.7~34.7)										
QLSWC200VR	CW	32.5	39	33.5	40	1.2	1.8	37	8	45	20.7	65	30	12	8.4
QLSWC200VL	CCW	(31.9~33.1)	(38.4~39.6)	(32.9~34.1)	(39.4~40.6)										
QLSWC300VR	CW	36.5	46	39	48.5	1.5	2.3	45	8	55	25.4	85	40	15	10.5
QLSWC300VL	CCW	(35.7~37.2)	(45.2~46.7)	(38.2~39.7)	(47.7~49.2)										

*) Clamping height can be adjusted. The parenthesized values denotes clamping height range.

Part Number	Dp	H	D	W ₁	W ₂	H ₃	H ₂	M	H ₄	R	A	H ₁	Cam Handles Part Number	Allowable Operating Load (N)**	Clamping Force (N)	Clamping Mechanism
QLSWC100VR	27	102	18	8	4.3	10	30	M4×0.7	22.8	50	16	52	QLCA-05	100	800	Spiral Cam Cam Angle:4°
QLSWC100VL																
QLSWC150VR	34	131	23	10	5.3	14	40	M5×0.8	28.5	63	19	68	QLCA-06	150	1,500	
QLSWC150VL																
QLSWC200VR	48	167	30	16	8.4	18	50	M8×1.25	45.5	80	24	87	QLCA-08	200	2,100	
QLSWC200VL																
QLSWC300VR	64	207	40	20	10.4	22	60	M10×1.5	57	100	30	107	QLCA-10	300	2,800	
QLSWC300VL																

***) Allowable load to operate the handle

QLSWC (Black Oxide Finish)		QLSWC-NP On Request (Electroless Nickel Plated)	
Part Number	Weight (g)	Part Number	Weight (g)
QLSWC100VR	134	QLSWC100VR-NP	134
QLSWC100VL			
QLSWC150VR	272	QLSWC150VR-NP	272
QLSWC150VL			
QLSWC200VR	625	QLSWC200VR-NP	625
QLSWC200VL			
QLSWC300VR	1,340	QLSWC300VR-NP	1,340
QLSWC300VL			

Technical Data

Allowable Loads in Machining of Workpiece Bottom

Ensure that any force more than stated below is not applied.

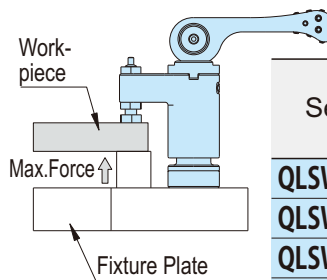

Series	Allowable Force To Workpiece Bottom (Per Clamp)
QLSWC100	Max.2,300N
QLSWC150	Max.3,600N
QLSWC200	Max.3,700N
QLSWC300	Max.5,600N

How To Use

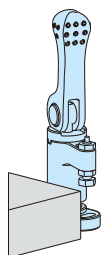

1. Unclamped Load or unload a workpiece.

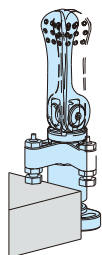

2. Arm Swing Turn the handle to set the clamp arm in position.

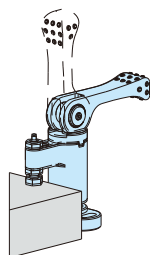

3. Clamping Set the handle down to clamp the workpiece.

Performance Curve

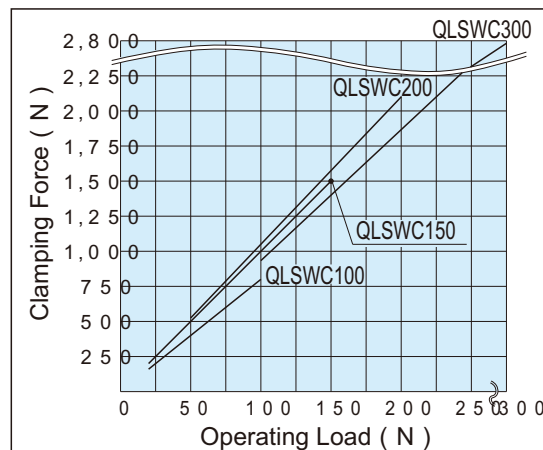

QLSWC - Swing Clamps (Mini) with Adjustable Handle



Base/Washer/Clamping Spindle	Body	Handle
Steel (S 4 5 C) Quenched and tempered Black oxide finish	Steel (SCM 4 4 0) Quenched and tempered Black oxide finish	ZDC 1 die cast zinc Coated with paint Black

- Clamp worked by a screw-locking mechanism which allows providing longer clamping stroke and greater clamping force than a cam-locking mechanism.
- Operated by an adjustable handle that allows for flexible handle positioning.

Counterclockwise Clamping

Clockwise Clamping

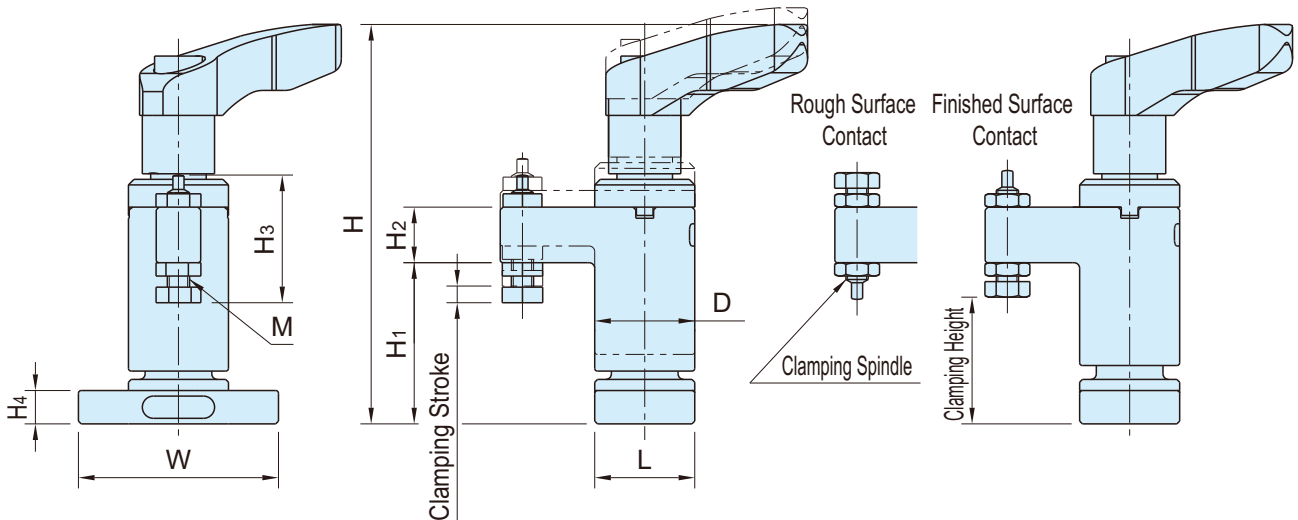
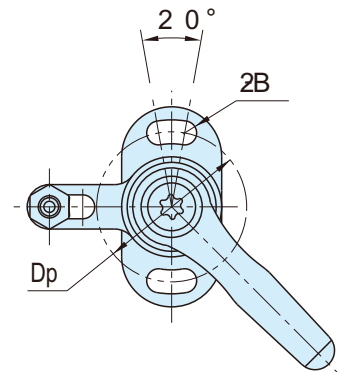
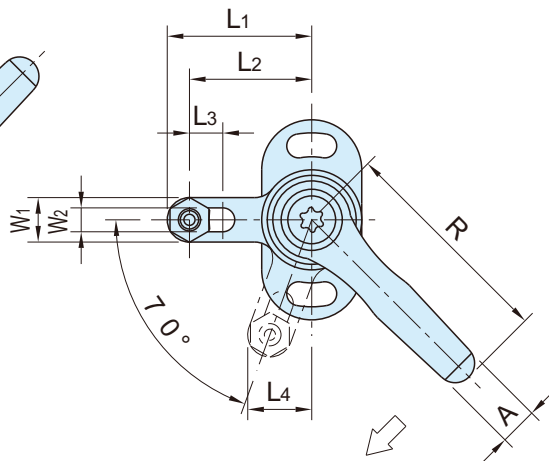
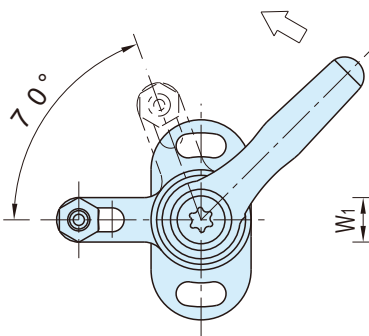

QLSWC - Swing Clamps (Mini) with Adjustable Handle

Part Number	Clamping Direction	Clamping Height *)				Clamping Stroke	L ₂	L ₃	L ₁	L ₄	W	L	H ₄	B	Dp		
		Finished Surface Contact		Rough Surface Contact													
		Min.	Max.	Min.	Max.												
QLSWC-0618KR	CW	21.8	23.8	21.4	23.4	3	22	6	26	11.5	36	18	6	4.3	27		
QLSWC-0618KL	CCW	(21.8~24.8)	(23.8~26.8)	(21.4~24.4)	(23.4~26.4)												
QLSWC-0823KR	CW	30.3	32.3	31.2	33.2	4	30	8	35	15.3	45	23	8	5.3	34		
QLSWC-0823KL	CCW	(30.3~34.3)	(32.3~36.3)	(31.2~35.2)	(33.2~37.2)												
QLSWC-1030KR	CW	30.5	37	31.5	38				37	8	45	20.7	65	30	12	8.4	48
QLSWC-1030KL	CCW	(30.5~34.5)	(37~41)	(31.5~35.5)	(38~42)												
QLSWC-1240KR	CW	34.5	44	37	46.5	5	45	55	25.4	85	40	15	10.5	64			
QLSWC-1240KL	CCW	(34.5~39.5)	(44~49)	(37~42)	(46.5~51.5)												

*) Clamping height can be adjusted. The parenthesised values denote clamping height range.

Part Number	H	D	W ₁	W ₂	H ₂	H ₁	M	R	A	H ₃	Adjustable Handles	Allowable Operating Load (N) **)	Clamping Force (N)	Weight (g)
QLSWC-0618KR	71.9	18	8	4.3	10	29	M 4×0.7	40	7	22.8	FKF 6-BR	170	2,000	121
QLSWC-0618KL														
QLSWC-0823KR	97.3	23	10	5.3	14	39	M 5×0.8	65	9.5	28.5	FKF 8-BR	350	3,200	276
QLSWC-0823KL														
QLSWC-1030KR	122.3	30	16	8.4	18	48	M 8×1.25	80	11	45.5	FKF10-BR	410	4,500	600
QLSWC-1030KL														
QLSWC-1240KR	145.7	40	20	10.4	22	58	M10×1.5	95	13	57	FKF12-BR	410	6,000	1,225
QLSWC-1240KL														

***) Allowable load to operate the handle.

How To Use

Turning the handle allows the clamp arm to swing for clamping.

Lifting the handle allows the handle to be disengaged from the teeth of the locking element and then be turned to a desired position.

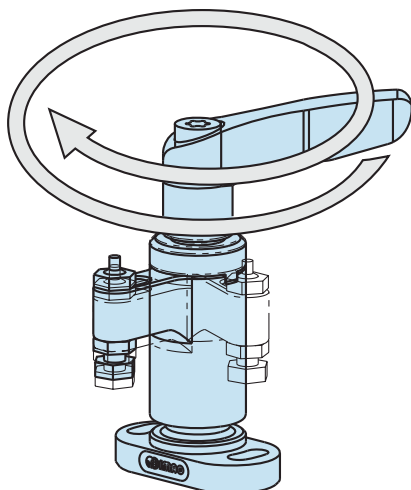

Performance Curve

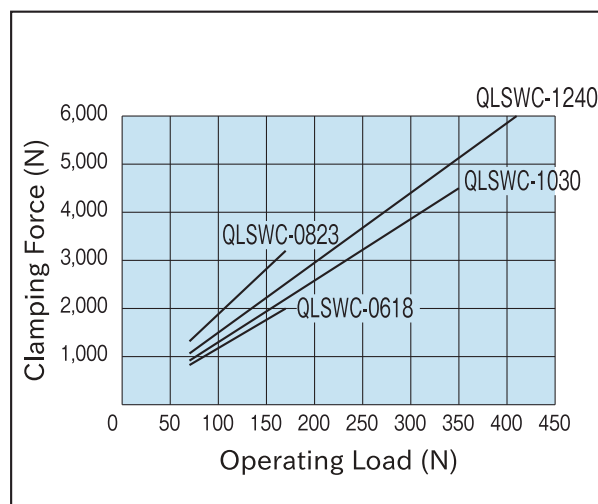

QLRE - Retractable Clamps (Mini) with Cam Handle



Body/Spindle	Arm/Joint	Cam Handle
Steel(S45C) Quenched and tempered Black oxide finish	Steel(SCM435) Quenched and tempered Black oxide finish	Steel(SCM440) Quenched and tempered Black oxide finish

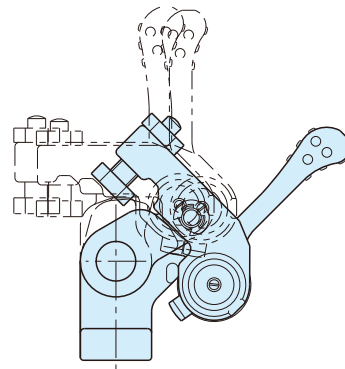
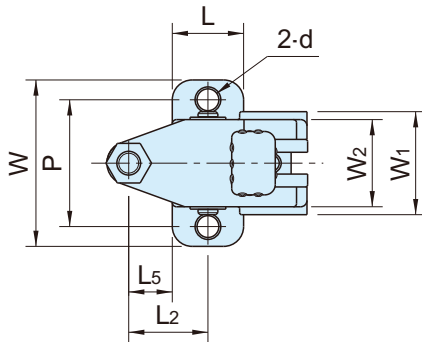

Unclamped

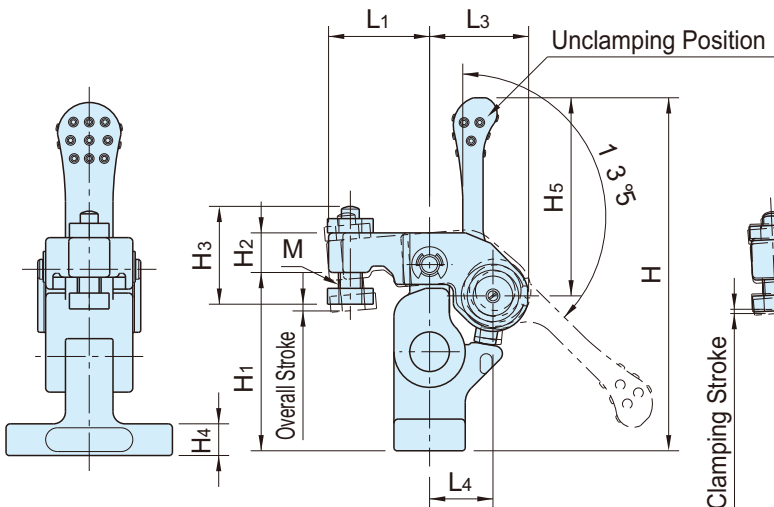

Clamping Position

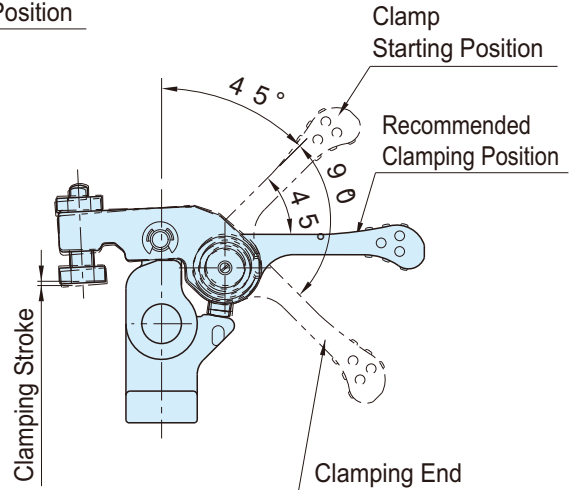

Clamping Throw

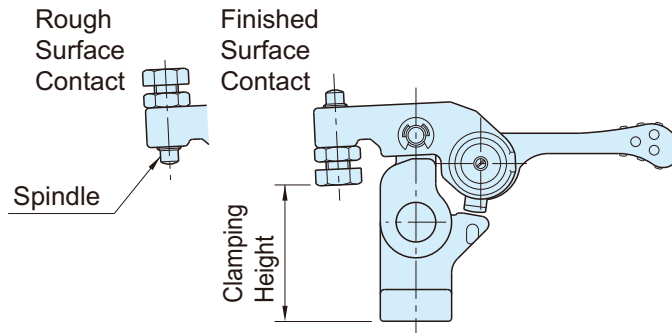

QLRE - Retractable Clamps (Mini) with Cam Handle

Part Number	Clamping Height *)				Clamping Stroke	Overall Stroke	L ₂	L ₅	W	L	H ₄	d	P	H	L ₁	L ₃
	Finished Surface Contact		Rough Surface Contact													
	min.	max.	min.	max.												
QLRE100	32 (31.5~32.5)	40 (39.5~40.5)	35 (34.5~35.5)	43 (42.5~43.5)	1	1.5	20	11	42	18	8	5.5	32	89	25.5	25
QLRE150	37 (36.4~37.6)	48 (47.4~48.6)	42 (41.4~42.6)	53 (52.4~53.6)	1.2	1.8	25	14	52	22	10	6.6	40	109	32	31

*)Clamping height can be adjusted. The parenthesised values denote actual clamping height.

Part Number	W ₁	W ₂	H ₂	H ₁	M	H ₃	H ₅	L ₄	Cam Handles Part Number	Allowable Operating Load (N)**)	Clamping Force(N)	Clamping Mechanism	Weight (g)
QLRE100	26	22	10	45	M6×1	24	50	16	QLCA-05	100	700	Spiral Cam	244
QLRE150	32	28	12	55	M8×1.25	30.5	63	20	QLCA-06	150	1,100	Cam Angle:4°	468

**)Allowable load to operate the handle

How To Use

How To Operate

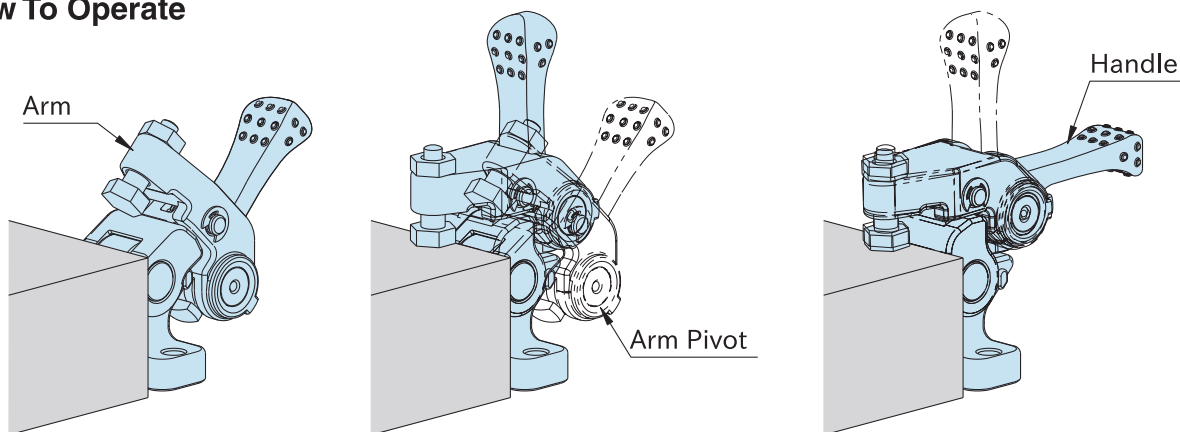

1. Unclamped
Load a workpiece.

2. Clamping Setup
Set the arm in clamping position holding it at the arm pivot.

3. Clamping
Set the handle down to clamp the workpiece.
For unclamping, follow the above steps back.

Technical Information

Allowable Loads in Machining of Workpiece Bottom

Ensure that any force more than stated below is not applied.

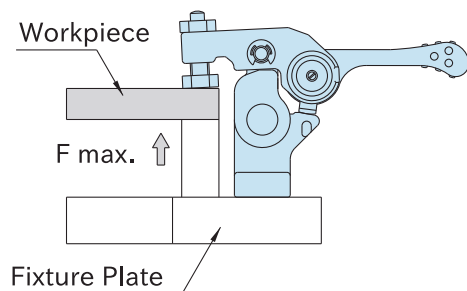

Part Number	Allowable Force to Workpiece Bottom (per Clamp)
QLRE100	max.5,000N
QLRE150	max.6,000N

Performance Curve

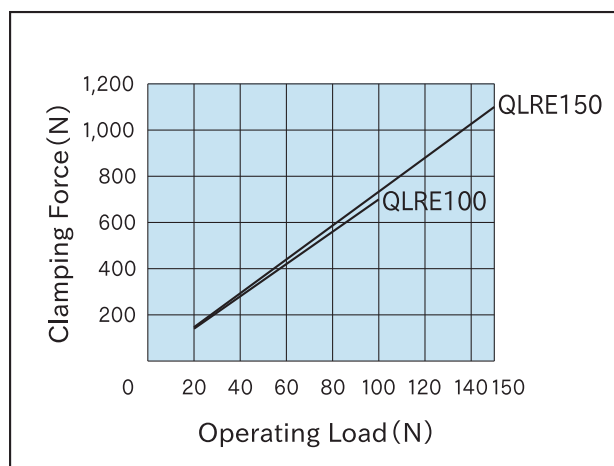

QLRE - Retractable Clamps (Mini) with Adjustable Handle



Body/Spindle	Arm/Joint
Steel(S45C) Quenched and tempered Black oxide finish	Steel(SCM435) Quenched and tempered Black oxide finish

• Screw clamping mechanism allows for longer clamping stroke and greater clamping force.

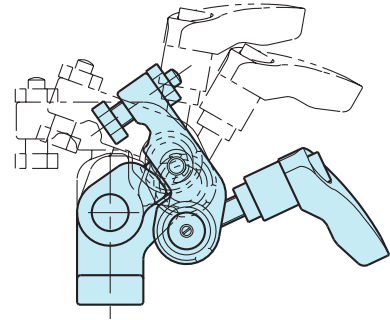
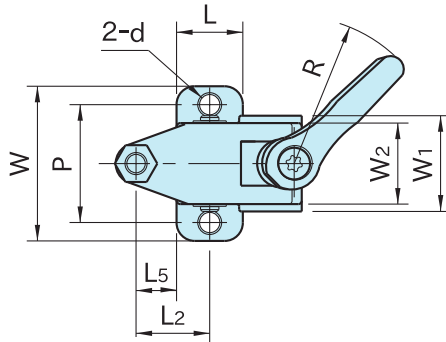

Unclamped

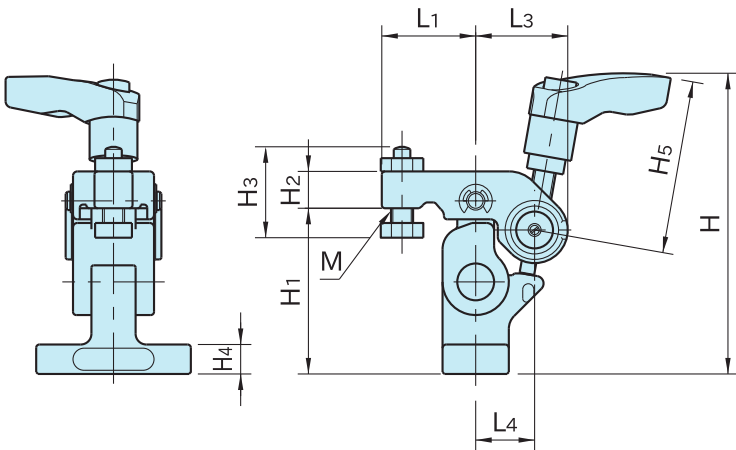

Clamping Position

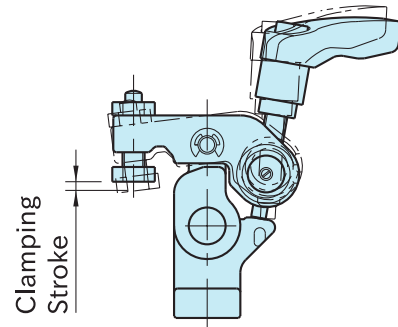

Clamping Stroke

Clamping Throw

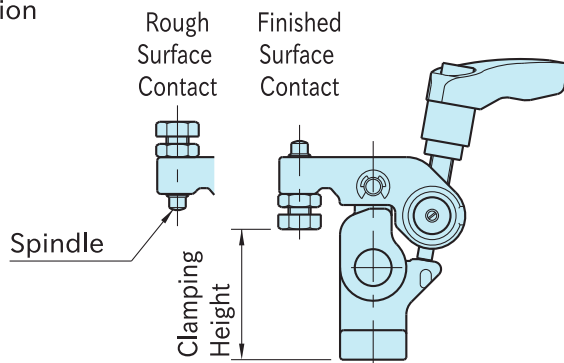

QLRE - Retractable Clamps (Mini) with Adjustable Handle

Part Number	Clamping Height *)				Clamping Stroke	L ₂	L ₅	W	L	H ₄	d	P	H	L ₁	L ₃	W ₁
	Finished Surface Contact		Rough Surface Contact													
	min.	max.	min.	max.												
QLRE-06	32 (32~29.5)	40 (40~37.5)	35 (35~32.5)	43 (43~40.5)	2.5	20	11	42	18	8	5.5	32	81	25.5	25	26
QLRE-08	37 (37~33.5)	48 (48~44.5)	42 (42~38.5)	53 (53~49.5)	3.5	25	14	52	22	10	6.6	40	100	32	31	32

*)Clamping height can be adjusted. The parenthesised values denote actual clamping height.

Part Number	W ₂	H ₂	H ₁	M	H ₃	R	H ₅	L ₄	Adjustable Handles	Allowable Operating Load (N)**)	Clamping Force (N)	Clamping Mechanism	Weight (g)
QLRE-06	22	10	45	M6×1	24	40	47	16	FKF6-BR	170	2,400	Srew	242
QLRE-08	28	12	55	M8×1.25	30.5	65	63	20	FKF8-BR	210	4,200		490

**))Allowable load to operate the handle.

How To Use

How To Operate

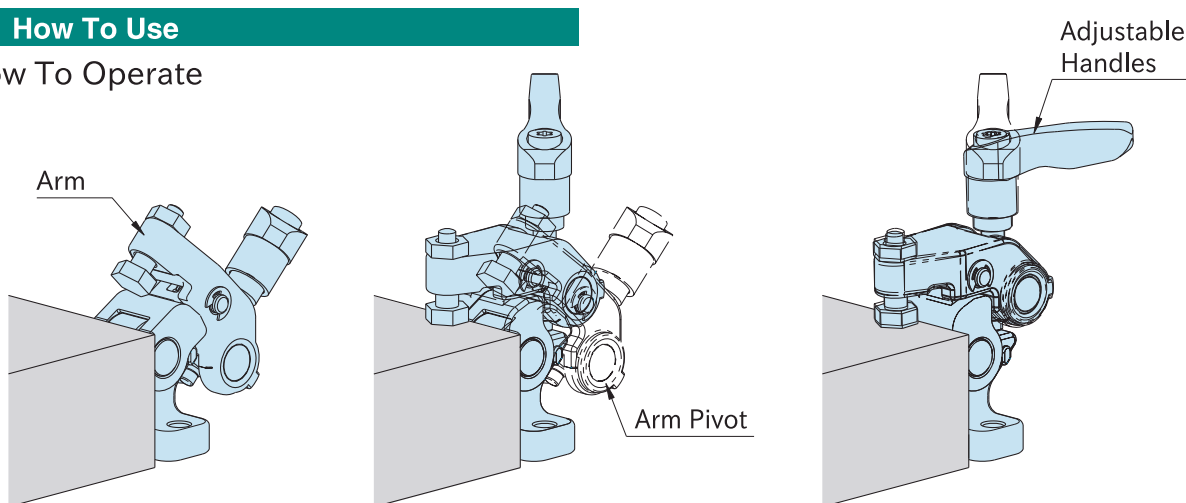

1.Unclamped
Load a workpiece.

2.Clamping Setup
Set the arm in clamping position holding it at the arm pivot.

3.Clamping
Tighten the adjustable handle to clamp the workpiece.
For unclamping, follow the above steps back.

Technical Information

Allowable Loads in Machining of Workpiece Bottom

Ensure that any force more than stated below is not applied.

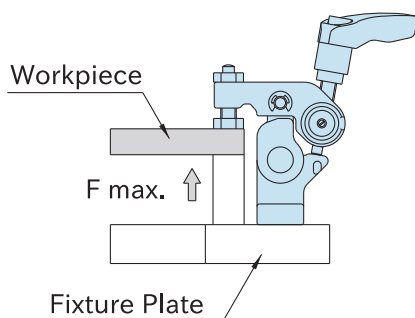

Part Number	Allowable Force to Workpiece Bottom (per Clamp)
QLRE-06	max.5,000N
QLRE-08	max.6,000N

Performance Curves

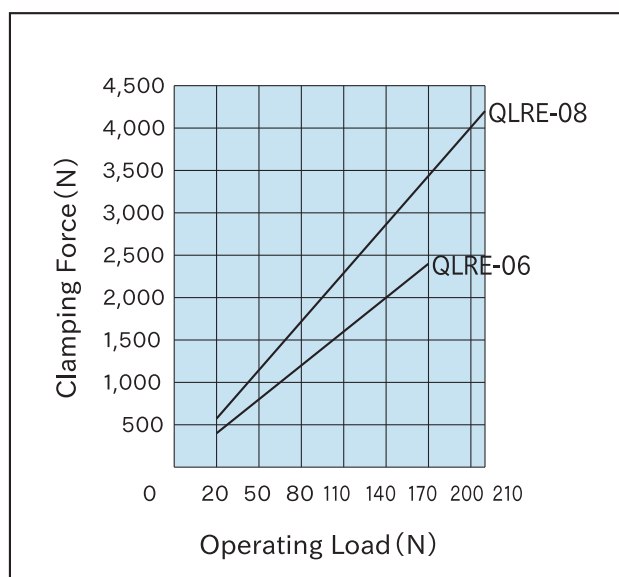

QLSCH - Cam Edge Clamps



QLSCH-L
(Light-Duty)



QLSCH
(Standard)

Type	Body	Jaw/Handle Shaft	Handle
QLSCH-L	S45C steel Black oxide finished	S45C steel Quenched & tempered Black oxide finished	SCM440 steel Quenched & tempered Electroless nickel plated
QLSCH			SCM440 steel Quenched & tempered Black oxide finished

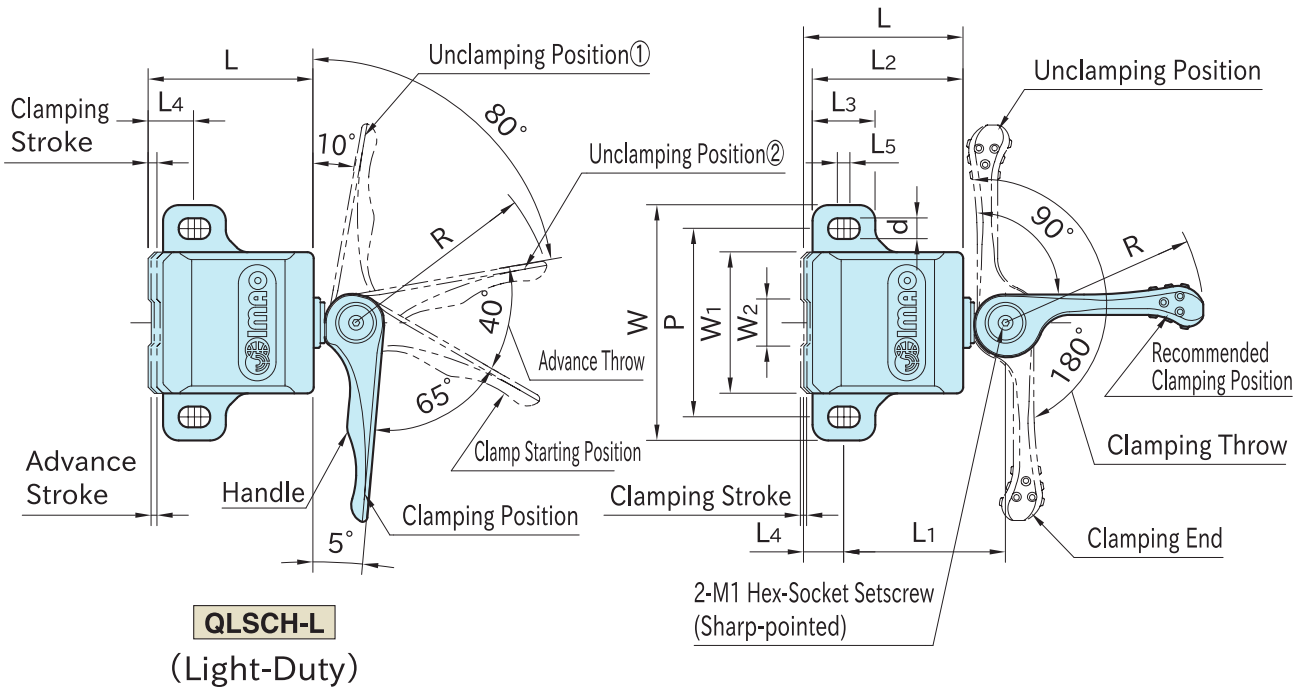

QLSCH-L
(Light-Duty)

QLSCH
(Standard)

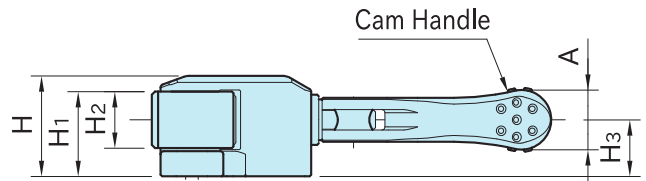
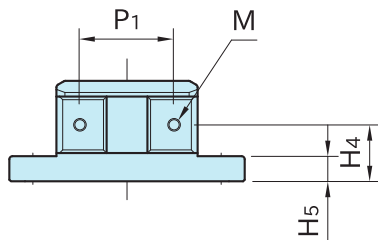

QLSCH - Cam Edge Clamps

Size	W ₁	W ₂	H ₁	H ₂	M	P ₁	H ₄	L ₄	W	L ₃	H ₅	d	L ₅	P
QLSCH32	45	15	27	18	M4×0.7 6deep	30	18	13	75	20	8	6.6	3	60
QLSCH40	60	20	33	22	M5×0.8 8deep	40	22	17	100	26	10	8.6	4	80

Size	H	L	L ₂	R	L ₁	H ₃	M ₁
QLSCH32	32	51	48	63	51.5	18	M4×0.7-5L
QLSCH40	40	67	63	80	67	22	M5×0.8-6L

Light-Duty Style

Part Number	A	Clamping Stroke *	Advance Stroke	Operating Load (N) **	Clamping Force (N)	Weight (g)
QLSCH32L	14	0.3	0.8	40	600	600
QLSCH40L	18	0.4		50	1,200	1,320

*) Dimensional variations between workpieces should be 0.1 mm or less.

**) Load needed to turn the handle to clamping position

Standard Style

Part Number	A	Clamping Stroke	Handle Number	Operating Load (N) ***	Clamping Force (N)	Weight (g)
QLSCH32	19	1.6	QLCA-06	150	2,000	620
QLSCH40	24	2.2	QLCA-08	200	3,000	1,360

***) Allowable load to operate the handle

Performance Curve

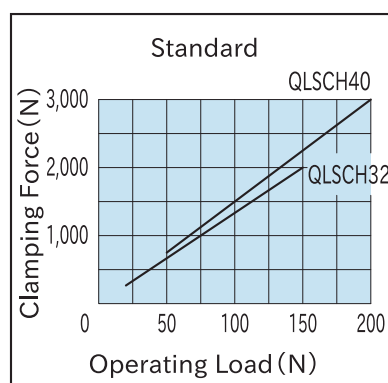

Features

- The cam handle allows fast clamping in single operation.
- Spring-loaded light-duty style allows distributing constant clamping force.
- Standard style allows adjusting clamping force depending on operating loads.
- Precision-ground jaw is perfect for clamping the workpiece on its finished surface.
- In clamping, the jaw provides downward force to prevent part lift

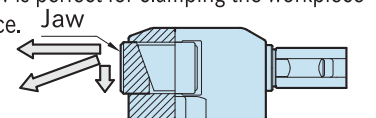

Changing Handle Position

The handle shaft has 4 countersinks which are provided every 90° for 4 options of handle position

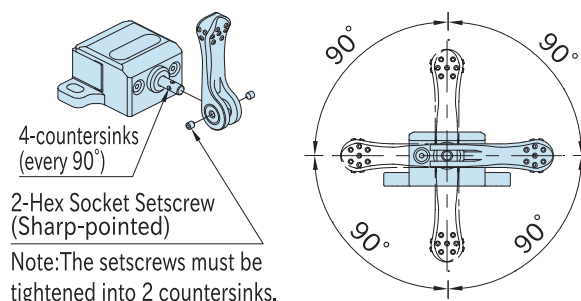

How To Use

Standard

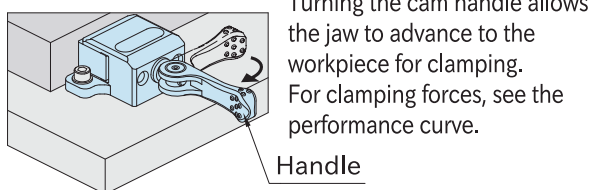

Light-Duty Style

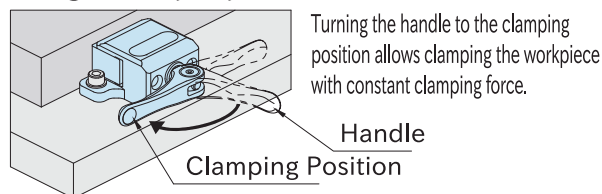

Installation Instructions for Light-Duty Style

The steps below must be followed so that constant clamping force can be distributed within the clamping stroke.

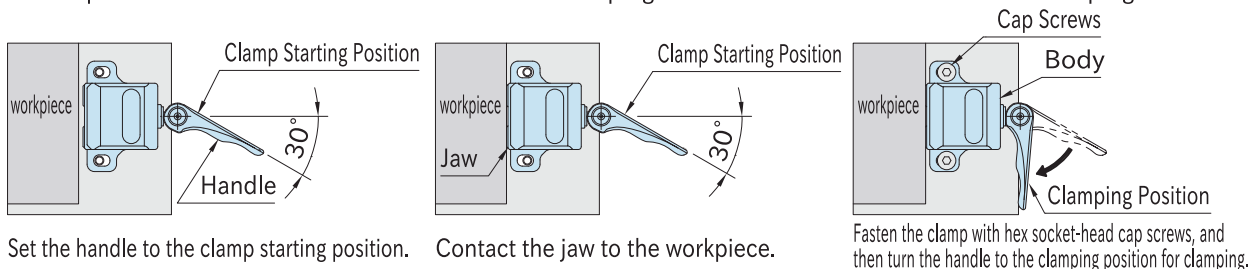



With Handle



Without Handle

Body	Jaw / Cam	Handle
Steel(S45C) Black oxide finish	Steel(SCM440) Quenched and tempered Black oxide finish	Steel(S45C) Quenched and tempered Black oxide finish

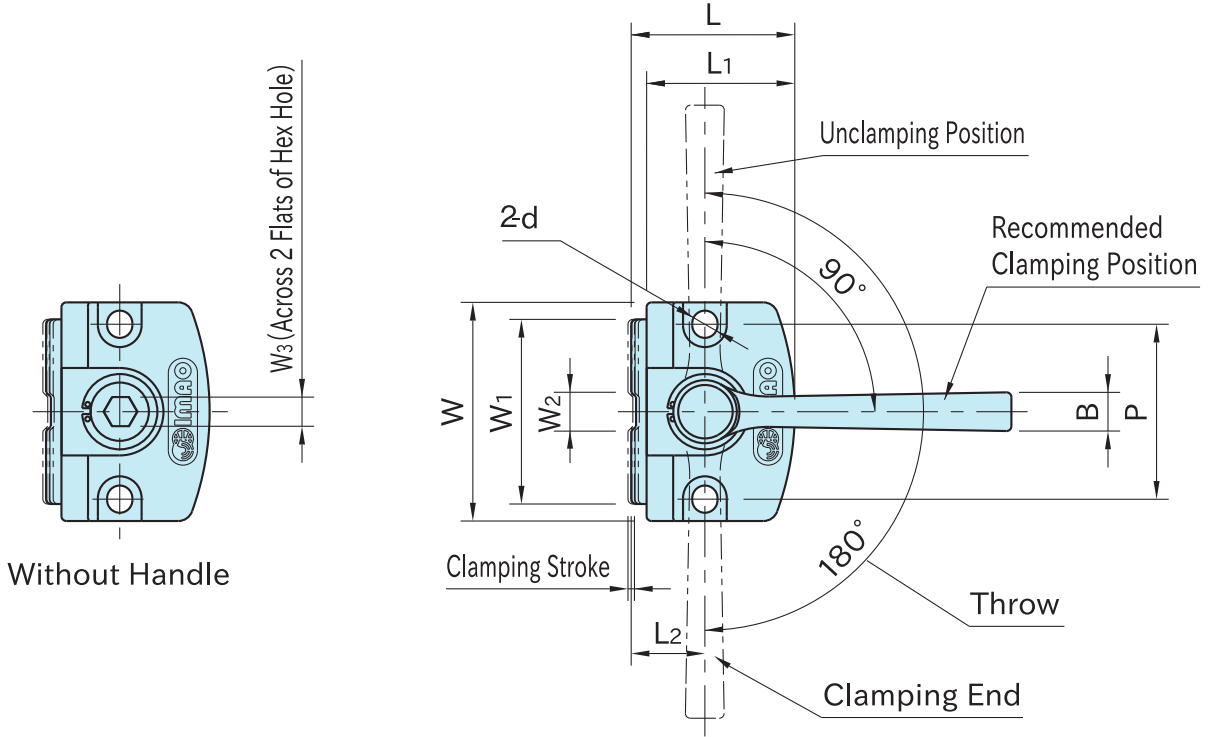

Without Handle

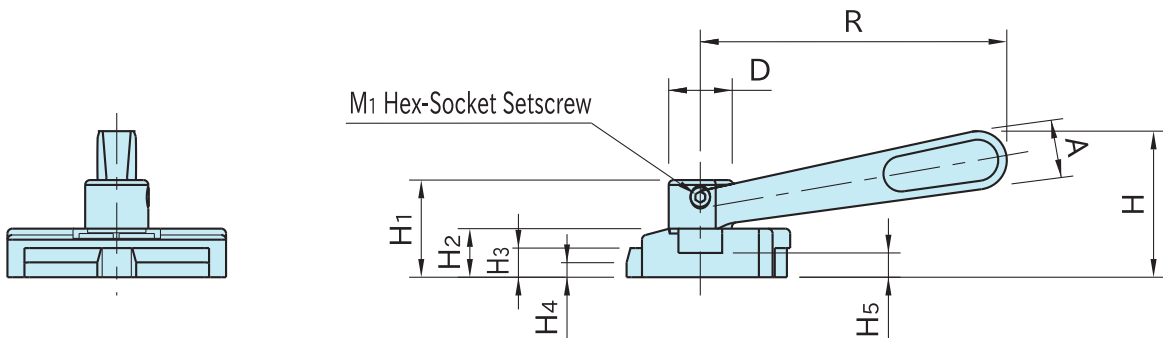

With Handle

QLSCL - Low-Profile Cam Edge Clamps

Series	Clamping Stroke	W ₁	W ₂	H ₃	H ₄	L ₂	W	L	H ₂	d	P	H ₅	L ₁	Clamping Mechanism
QLSCL10	1	38	8	6	3	15	45	33.5	10	5.2	36	5	30.5	Spiral Cam Cam Angle : 4°
QLSCL15	2	60	12	9	5	22	70	50	15	8.2	55	7	46	

With Handle

Part Number	H	D	H ₁	R	A	B	M ₁	Allowable Operating Load(N)*	Clamping Force (N)	Weight (g)
QLSCL10R	30	13	20	63	12	8	M4×0.7-4L	170	4,000	130
QLSCL15R	46	19	30	100	18	12	M5×0.8-5L	280	6,000	440

*) Allowable load to operate the handle

Without Handle

Part Number	W ₃	Allowable Screw Torque(N m)	Clamping Force (N)	Weight (g)
QLSCL10NR	6	10	4,000	85
QLSCL15NR	10	27	6,000	290

How To Change Handle Position

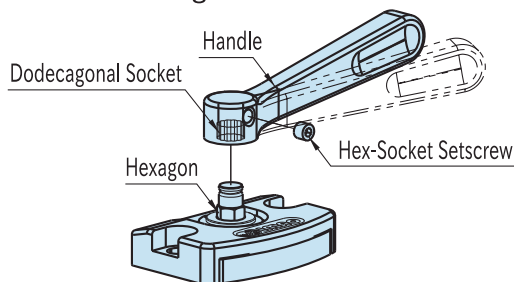

The handle has the dodecagonal socket to allow changing the handle position by 30°

Features

Designed to prevent part lift.

How To Use

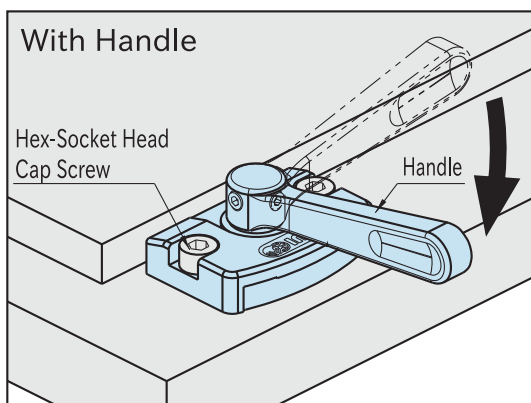

Turning the handle allows the cam to project the jaw for clamping. When the handle is turned back for unclamping, the loaded spring lets the jaw return to the original position.

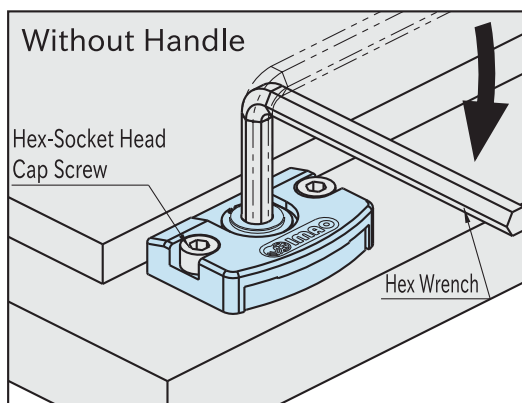

Use the without-handle style in applications where the handle lies in the way.

Performance Curve

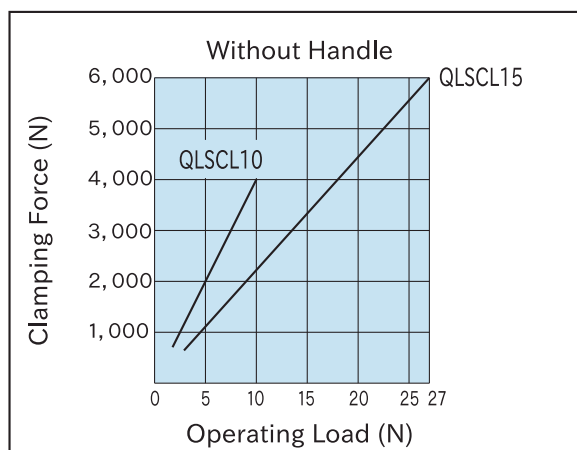
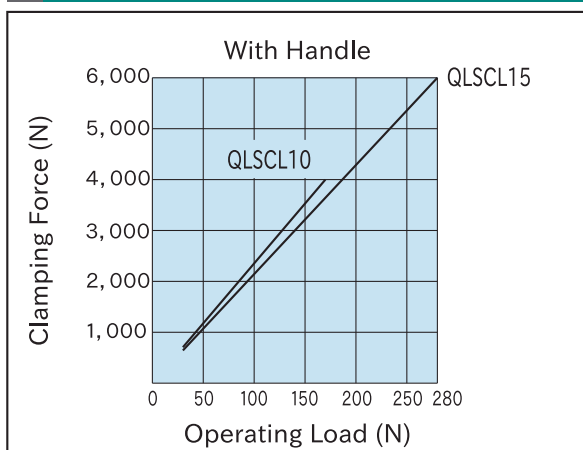

Notes

Ensure that mounting surfaces are finished to $\sqrt{6.3}$ (6.3a) or better, without any scratches or dents.



M8 Size



M12 Size

[Hook Clamp]

Material : SCM435 steel

Heat Treat : Quenched and tempered

Finish : Black oxide

Precision ground

[Holder]

Material : S45C steel

Finish : Black oxide

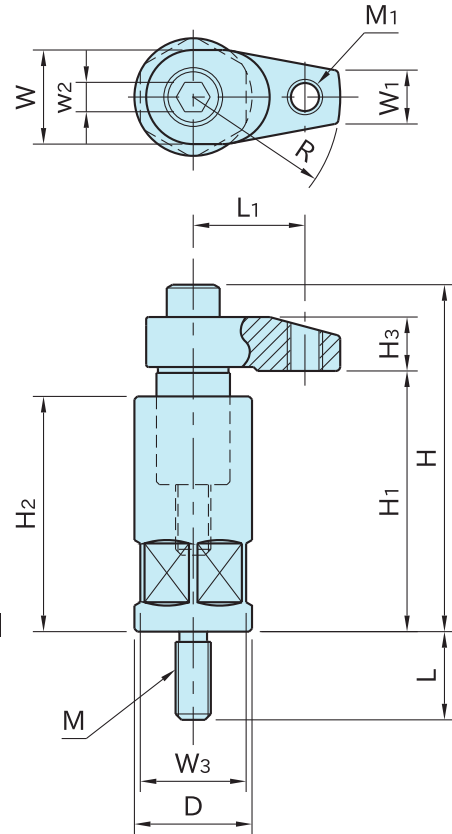

Part Number	H ₁	M ₁	L ₁	R	D	H ₂	M	L	H
BJ130-08020A1	55~65	-	-	20	24	55	M 8×1.25	19	69~ 79
BJ130-08025A1				25					
BJ130-08030A1				30					
BJ130-10030A1	63~75	-	-	30	32	63	M12×1.75	30	87~ 99
BJ130-10030A2	80~92					80			104~116
BJ130-10040A1	63~75			63		87~ 99			
BJ130-10040A2	80~92			80		104~116			

Part Number	W	W ₁	H ₃	w ₂	W ₃	Clamping Force (N)	Allowable Screw Torque (N·m)	Weight (kg)
BJ130-08020A1	22	10	12	6	22	12,000	30	0.23
BJ130-08025A1						11,000		0.24
BJ130-08030A1						10,000		0.25
BJ130-10030A1	25	12	15	8	30	13,000	38	0.60
BJ130-10030A2						0.70		
BJ130-10040A1						10,000	32	0.61
BJ130-10040A2						0.71		

Use [BJ600](#) Riser Cylinders for additional height.

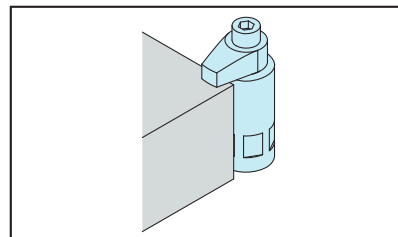

BJ130-A Hook-Clamp Assemblies

Part Number	H ₁	M ₁	L ₁	R	D	H ₂	M	L	H		
BJ130-12040A1	80~95	-	-	40	40	80	M12×1.75	30	107~122		
BJ130-12040A2	100~115					100			127~142		
BJ130-12050A1	80~95			50		50			80	109~124	
BJ130-12050A2	100~115								100	129~144	
BJ130-12060A1	80~95			60		60			80	109~124	
BJ130-12060A2	100~115								100	129~144	
BJ130-12140A1	80~95	M12×1.75	31	40	40	80	M12×1.75	30	107~122		
BJ130-12140A2	100~115					100			127~142		
BJ130-12150A1	80~95		38	50		50			80	109~124	
BJ130-12150A2	100~115								100	129~144	
BJ130-12160A1	80~95		46	60		60			80	109~124	
BJ130-12160A2	100~115								100	129~144	
BJ130-16040A1	80~95	-	-	40	50	80	M16×2	30	116~131		
BJ130-16040A2	100~115					100			136~151		
BJ130-16050A1	80~95			50		50			50	80	116~131
BJ130-16050A2	100~115									100	136~151
BJ130-16060A1	80~95			60		60			60	80	116~131
BJ130-16060A2	100~115									100	136~151
BJ130-16150A1	80~95	M12×1.75	38	50	50	80	M16×2	30	116~131		
BJ130-16150A2	100~115					100			136~151		
BJ130-16160A1	80~95		46	60		60			80	116~131	
BJ130-16160A2	100~115								100	136~151	

Part Number	W	W ₁	H ₃	w ₂	W ₃	Clamping Force (N)	Allowable Screw Torque (N·m)	Weight (kg)				
BJ130-12040A1	32	18	16	10	36	15,000	50	1.36				
BJ130-12040A2								1.56				
BJ130-12050A1			18			14,000	18	50	1.39			
BJ130-12050A2									1.59			
BJ130-12060A1			12,000			46	16	50	1.43			
BJ130-12060A2									1.63			
BJ130-12140A1			15,000			50	18	46	1.36			
BJ130-12140A2									1.56			
BJ130-12150A1			14,000			50	18	46	1.39			
BJ130-12150A2									1.59			
BJ130-12160A1			12,000			46	18	46	1.43			
BJ130-12160A2									1.63			
BJ130-16040A1	36	22	21	14	46	18,000	80	2.11				
BJ130-16040A2								2.42				
BJ130-16050A1						16,500		80	21	14	46	2.16
BJ130-16050A2												2.47
BJ130-16060A1						16,000		80	21	14	46	2.22
BJ130-16060A2												2.53
BJ130-16150A1						16,500		80	21	14	46	2.16
BJ130-16150A2												2.47
BJ130-16160A1						16,000		80	21	14	46	2.22
BJ130-16160A2												2.53

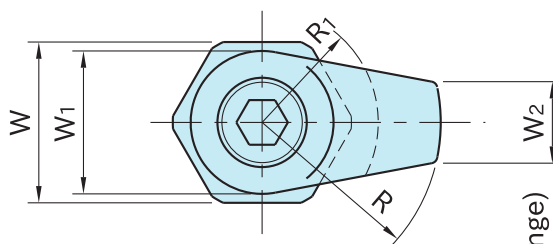

M1 Hex.Socket-Head Cap Screw

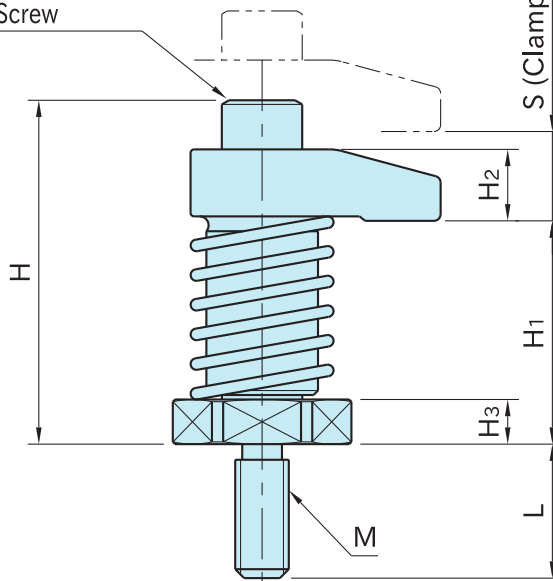

Body
Steel(SCM435)
Heat treated
Black oxide finish
Precision ground

Part Number	H ₁	S	R	R ₁	M	L	H	W ₁	W ₂	H ₂	W									
BJ131-08020	35	10	20	15	M 8×1.25	19	49	22	10	12	22									
BJ131-08025			25																	
BJ131-08030			30	15 *)																
BJ131-08120	45	10	20	15			M 8×1.25					19	59	22	10	12	22			
BJ131-08125			25																	
BJ131-08130			30	15 *)																
BJ131-12040	50	15	40	26	M12×1.75	30		77	32	18	16		36							
BJ131-12050			50					79			18									
BJ131-12060			60					92			16									
BJ131-12140	65		15				40	26			M12×1.75	30		94	32	18	18	36		
BJ131-12150							50							94			18			
BJ131-12160							60							94			18			
BJ131-16040	50	15		40	26	M16×2	30		86	36			22	21			36			
BJ131-16050				50					86										21	
BJ131-16060				60					101										21	
BJ131-16140	65		15	40				26	M16×2		30	101			36	22		21	36	
BJ131-16150				50								101								21
BJ131-16160				60								101								21

*) The center of R1 is located in 5mm outside from the center of the body.

BJ131-Hook-Clamp Assemblies

Part Number	H ₃	M ₁	Clamping Force(N)	Allowable Screw Torque (N·m)	Weight (g)
BJ131-08020	6	M 8×1.25-30L	7,900	20	125
BJ131-08025			7,300		130
BJ131-08030			6,700		135
BJ131-08120			7,900		160
BJ131-08125			7,300		165
BJ131-08130			6,700		170
BJ131-12040	10	M12×1.75-45L	13,500	45	450
BJ131-12050			12,600		480
BJ131-12060			11,700		520
BJ131-12140			13,500		600
BJ131-12150			12,600		630
BJ131-12160			11,700		670
BJ131-16040	10	M16×2 -55L	13,400	60	630
BJ131-16050			12,400		680
BJ131-16060			12,000		740
BJ131-16140			13,400		780
BJ131-16150			12,400		830
BJ131-16160			12,000		890

BJ600 Riser Cylinders are available for additional height.

HOW TO USE

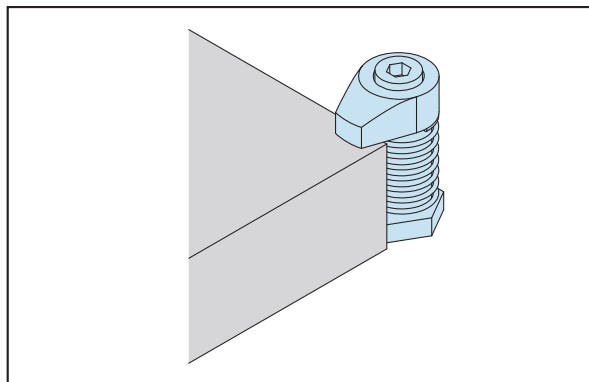



Serrated Nose



Smooth Nose

[Body]

Material : SCM440 steel
 Heat Treat : Quenched and tempered
 Finish : Black oxide

[Sliding Nose]

Material : SCM440 steel
 Heat Treat : Induction hardened on contact surface
 Finish : Black oxide
 Precision ground (smooth nose)

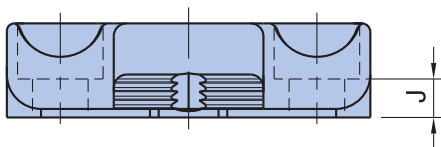
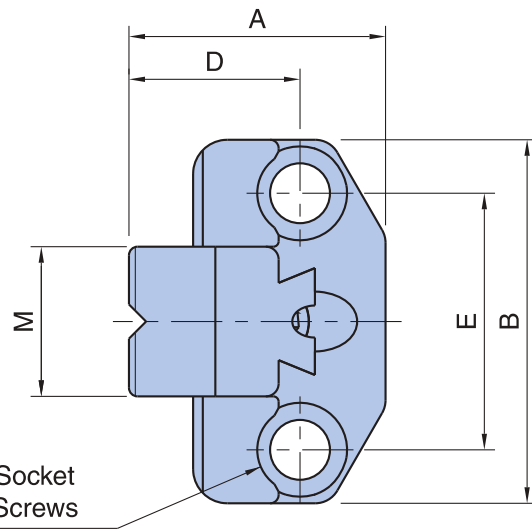

Serrated Nose

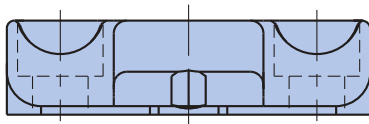
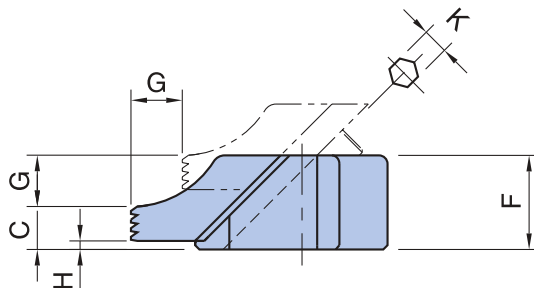

Smooth Nose

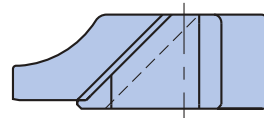

Nose	Part Number	A	B	C	D	E	F	G	H	J	K	L	M	Clamping Force(N)	Allowable Screw Torque (N·m)	Weight (g)
Serrated	CP104-08016	39.5	65	7.5	25	45	16	7	1.5	7	4	M 8	25	4,000	8	160
	CP104-12022	60	85	10	40	60	22	12	2	9	6	M12	35	9,000	26	450
	CP104-16030	77	100	14	50	70	30	14		13	8	M16	40	17,000	60	900
Smooth	CP104-08116	39.5	65	7.5	25	45	16	7	1.5	7	4	M 8	25	4,000	8	160
	CP104-12122	60	85	10	40	60	22	12	2	9	6	M12	35	9,000	26	450
	CP104-16130	77	100	14	50	70	30	14		13	8	M16	40	17,000	60	900

CP105-Side Clamps

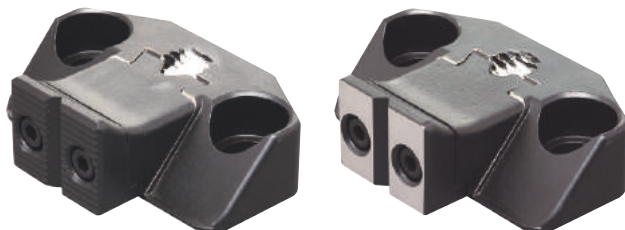

Serrated Nose

Smooth Nose

[Body & Jaw Carrier]
 Material : SCM440 steel
 Finish : Black oxide
 Heat Treat : Quenched and tempered

[Jaw]
 Material : SCM440 steel
 Finish : Black oxide
 Heat Treat : Quenched and tempered
 Precision ground (smooth nose)

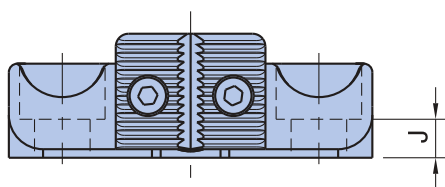
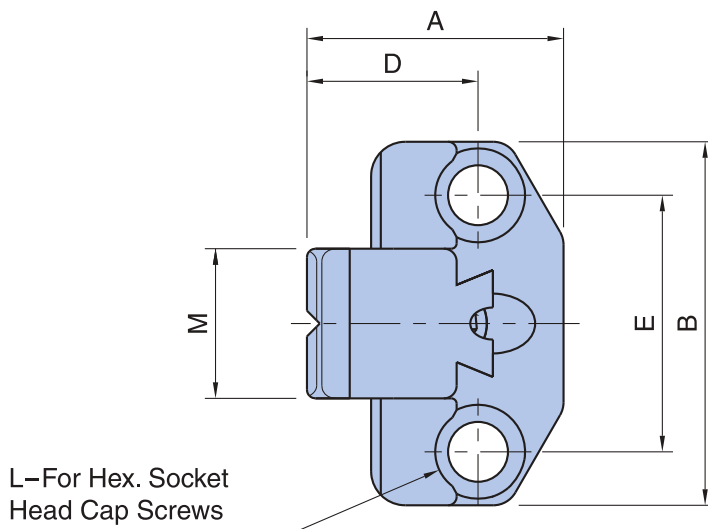

Serrated Nose

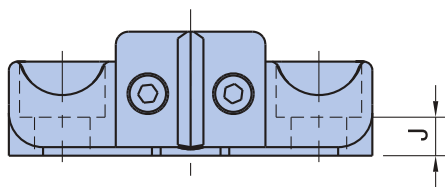
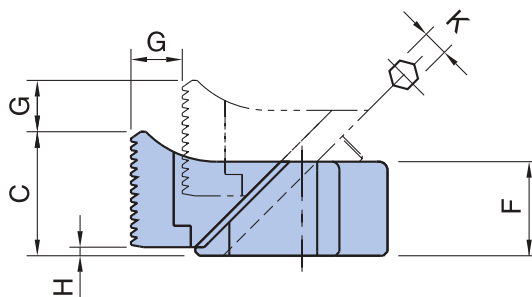

Smooth Nose

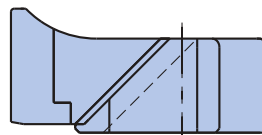

Nose	Part Number	A	B	C	D	E	F	G	H	J	K	L	M	Clamping Force (N)	Allowable Screw Torque (N·m)	Weight (g)
Serrated	CP105-08016	39.5	65	19.5	25	45	16	7	1.5	7	4	M 8	25	4,000	8	180
	CP105-12022	60	85	29	40	60	22	12	2	9	6	M12	35	9,000	26	500
	CP105-16030	77	100	38	50	70	30	14		13	8	M16	40	17,000	60	1,010
Smooth	CP105-08116	39.5	65	19.5	25	45	16	7	1.5	7	4	M 8	25	4,000	8	180
	CP105-12122	60	85	29	40	60	22	12	2	9	6	M12	35	9,000	26	510
	CP105-16130	77	100	38	50	70	30	14		13	8	M16	40	17,000	60	1,020

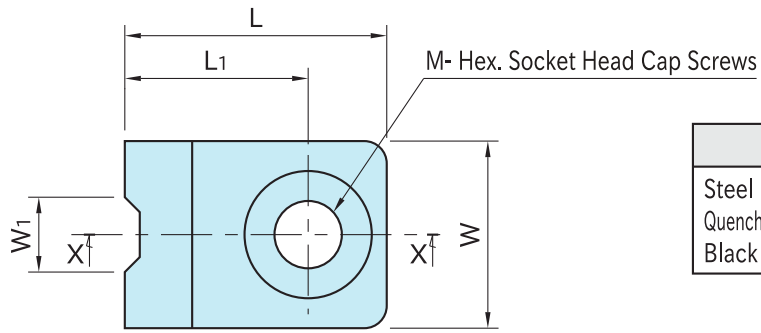

Body
Steel (S45C) Quenched and tempered Black oxide finish

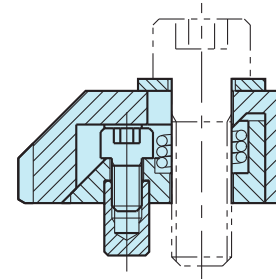
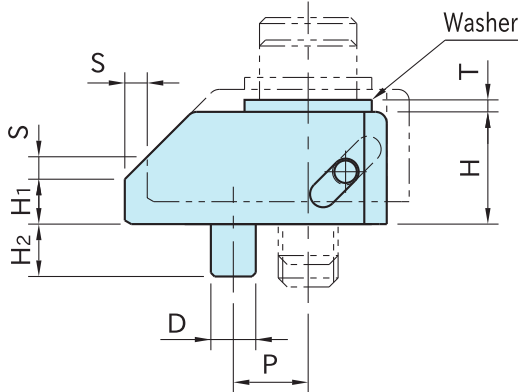
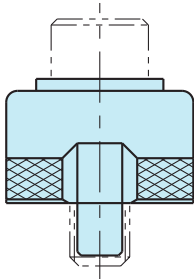

Section X-X

Part Number	S	W	W ₁	H ₁	L ₁	P	D (h7)	H ₂	M	L	H	T	Clamping Force (N)	Allowable Screw Torque (N·m)	Weight (g)
CP106-08015	3	25	10	6	24.5	10	6	7	M 8	35	15	1.6	7,000	25	100
CP106-10019	4	30	11	8	29	12			M10	43	19	2	8,500	50	185
CP106-12023	5	35	12	9	37	16	8	10	M12	54	23	2.3	20,000	90	320
CP106-16025	6	40	14	10	45	20			M16	65	25	3.2	30,000	150	520

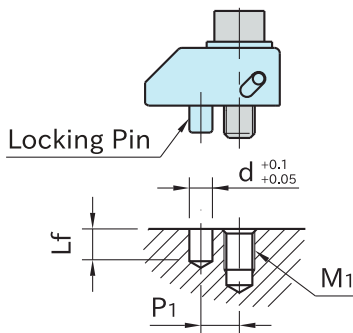

Part Number	M ₁	d	L _f	P ₁
CP106-08015	M 8	6	8	10
CP106-10019	M10			12
CP106-12023	M12	8	11	16
CP106-16025	M16			20

Drill a cap-screw hole and a locking-pin hole as specified on the left.

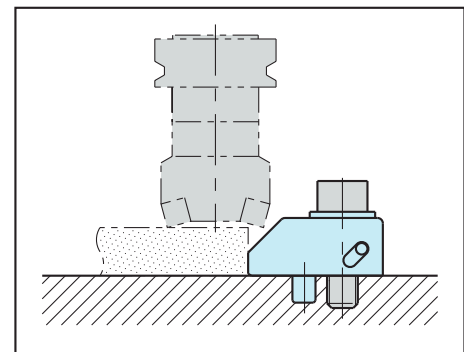

Furnished With

One flat washer is included.

CPI07-Side Clamps

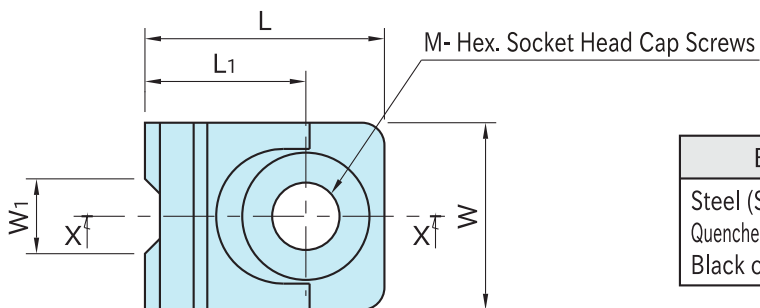

Body
Steel (S45C)
Quenched and tempered
Black oxide finish

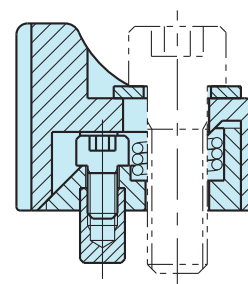
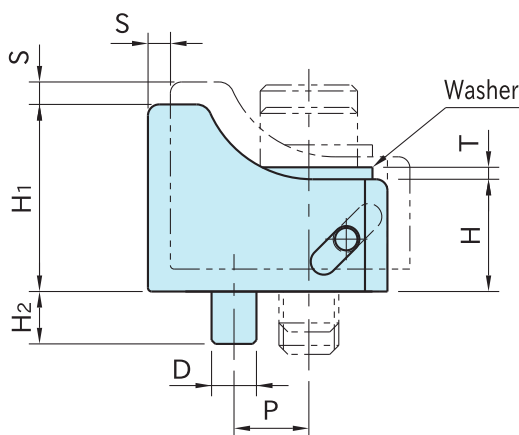
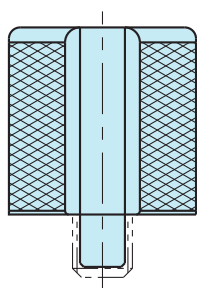

Section X-X

Part Number	S	W	W ₁	H ₁	L ₁	P	D (h7)	H ₂	M	L	H	T	Clamping Force (N)	Allowable Screw Torque (N·m)	Weight (g)
CP107-08015	3	25	10	25	21.5	10	6	7	M 8	32	15	1.6	7,000	25	115
CP107-10019	4	30	11	32	26	12			M10	40	19	2	8,500	50	225
CP107-12023	5	35	12	38	33	16	8	10	M12	50	23	2.3	20,000	90	390
CP107-16025	6	40	14	45	40	20			M16	60	25	3.2	30,000	150	640

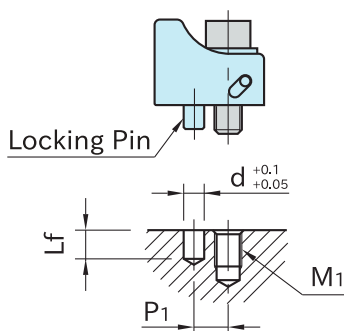

Part Number	M ₁	d	L _f	P ₁
CP107-08015	M 8	6	8	10
CP107-10019	M10			12
CP107-12023	M12	8	11	16
CP107-16025	M16			20

Drill a cap-screw hole and a locking-pin hole as specified on the left.

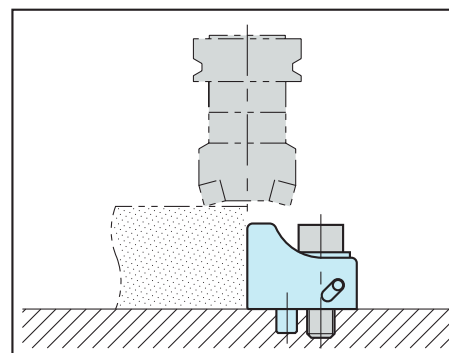

Furnished With

One flat washer is included.

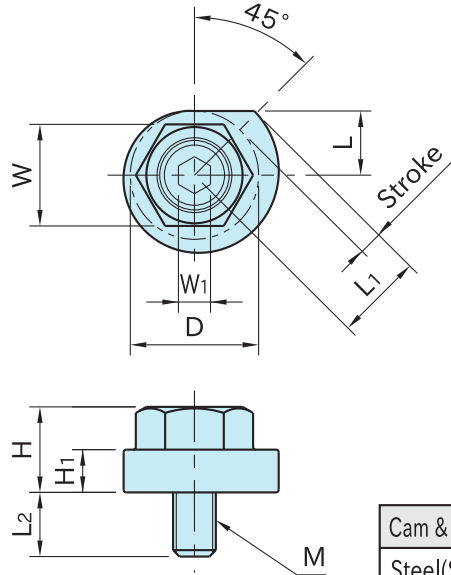

Cam & Locking Screw	Flanged Collar
Steel(SCM435) Quenched and tempered Black oxide finish	Steel(SK95) Quenched and tempered Black oxide finish

Part Number	Stroke	L	L1	D	H1	M	L2	H	W	W1
BJ161-08001	4.4	12	16.4	24	8	M 8×1.25	12	16	19	6
BJ161-10001	5.5	15	20.5	30	10	M10×1.5	15	20	24	8
BJ161-12001	6.2	17	23.2	34	12	M12×1.75	18	24	27	10

Part Number	Allowable Screw Torque(N·m)	Clamping Force(N)	Weight(g)
BJ161-08001	50	5,200	55
BJ161-10001	75	8,000	110
BJ161-12001	90	9,300	185

Features:

- Allows loading and unloading a part faster
- Compact design

How To Use

To install, lock the flanged collar into the cam using the locking screw and then tighten up the cam with a wrench.

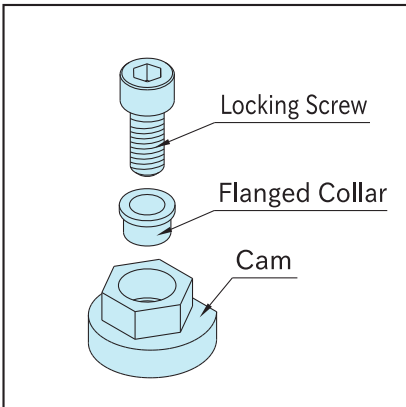

Parts Breakdown

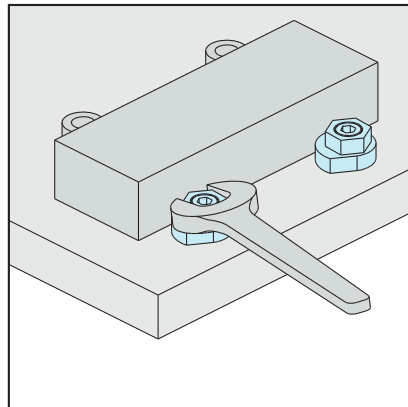

Provides positive clamping

CPI20-OD Holding Clamps



Body	Jaw
Steel (S45C) Black oxide finish	Aluminum (A7075) Blue
Shaft / Locking Screw	Housing / Locking Ring
Steel (SCM435) Black oxide finish Quenched and tempered	Steel (S45C) Black oxide finish

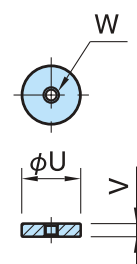
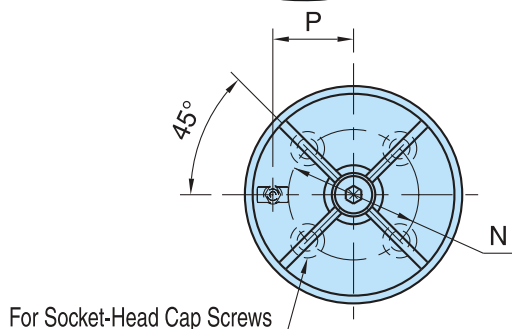

Locking Ring

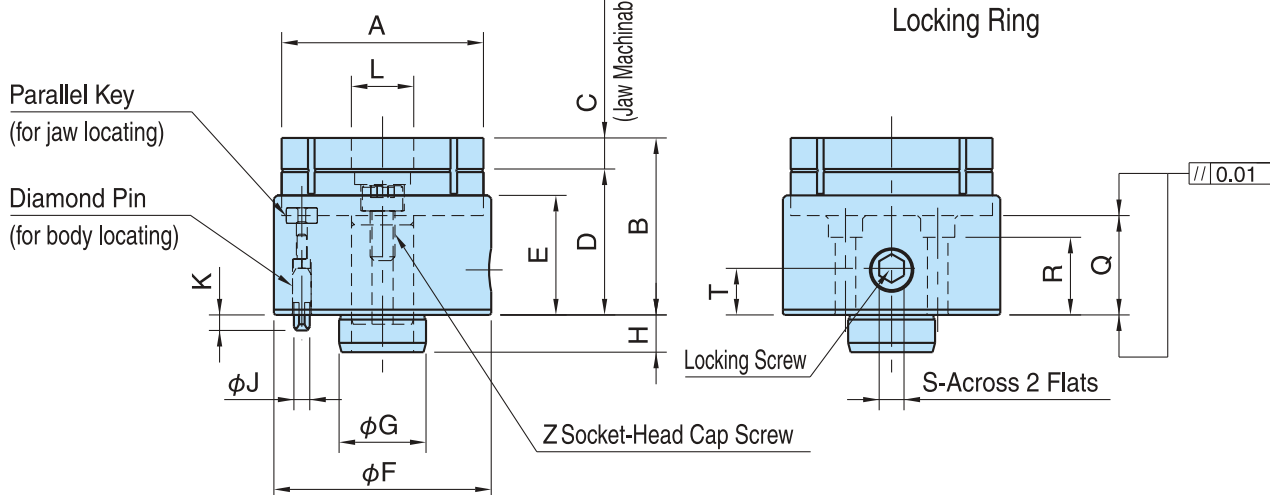

Part Number	A	B	C	D	E	F	G (g6)	H	J (h6)	K	L	M	N	P (±0.02)	Q (±0.01)	R
CP120-06501	65	57	10	47	39	70	28	12	6	5	19	M6	42	26	32	25
CP120-09001	90	72	15	57	46	95	42	14	8	7	23	M8	60	36	38	28

Part Number	S	T	U	V	W	Z	Clamping Force (N)	Allowable Screw Torque (N·m)	Weight (kg)
CP120-06501	8	15	18	4	M4x0.7	M 8x1.25-15L	4,000	60	1.1
CP120-09001	10	17	22	6	M5x0.8	M10x1.5 -20L	6,000	100	2.6

Technical Data:

- Part locating repeatability: ±0.03
- Jaw locating repeatability: ±0.02

Included:

- 1 of locking ring
- 1 of diamond pin
- 1 of socket-head cap screw

Notes:

- Never tighten the locking screw without a part mounted, to avoid damage and deformation.
- Do not machine the jaw deeper than allowed.

CPI20-OD Holding Clamps

Features:

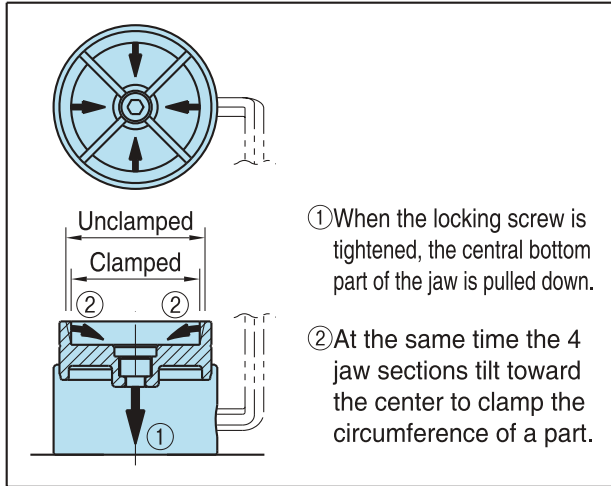

- The diaphragm clamping mechanism allows securely clamping a part with 4 jaw sections.
- Different irregularly-shaped parts can be clamped.
- 0.15mm clamping stroke of each jaw section is perfect for clamping of lost-wax parts, die-cast parts, extruded parts, solid-drawn parts, prefinished parts, etc.

Hole Preparation

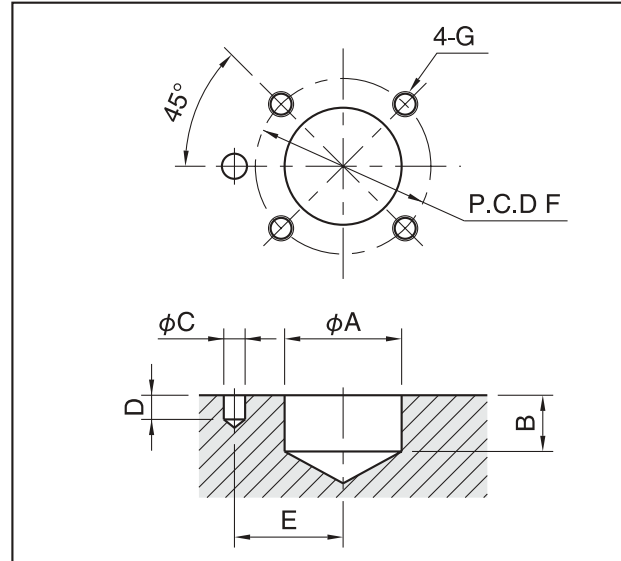

Part Number	A (H7)	B	C (G7)	D (±0.02)	F (P.C.D)	G
CP120-06501	28	13	6	6	42	M6X1
CP120-09001	42	15	8	8	60	M8X1.25

How To Use

① Body Mounting

Socket-Head Cap Screws
Diamond Pin
Body

Insert an included diamond pin into the body for locating, and then secure the body to the fixture plate with 4 socket-head cap screws.

② Jaw Setting

Socket-Head Cap Screw
Jaw
Parallel Key
Locking Screw

Engage the keyway on the bottom of the jaw with the parallel key on the top of the body, and then secure the jaw with an included cap screw.
Note : At jaw installation, ensure the locking screw is fully loosened by turning counterclockwise until it stops.

③ Jaw Machining

(Bolt)
Locking Ring
Socket-Head Cap Screw

Note : Locate the locking ring in full contact with the top of the cap screw's socket.

(1) Set the locking ring in the jaw. (using a bolt facilitates setting)

④ Part Setting

Locking Ring
Part

- After machining loosen the locking screw to take out the locking ring.
- Mount a part and then tighten the locking screw for clamping.

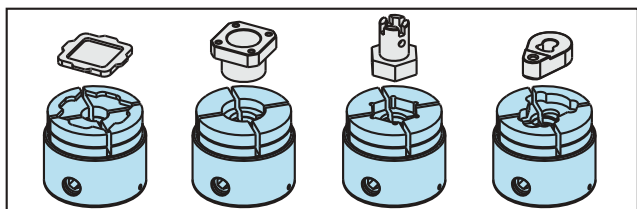

- Tightening the locking screw on the side of the body allows holding a part on its circumference.
- Machinable jaws allow clamping parts of various shapes.
- Ideal way to hold parts for machining on small-size machining centers, tapping centers, small-size 5-axis machines, CNC rotary tables, etc.

CPI23-OD Holding Clamps (Wedge Style/Round)



Body	Wedge
Steel(S45C) Black oxide finished	Steel(S45C) Black oxide finished Quenched & tempered

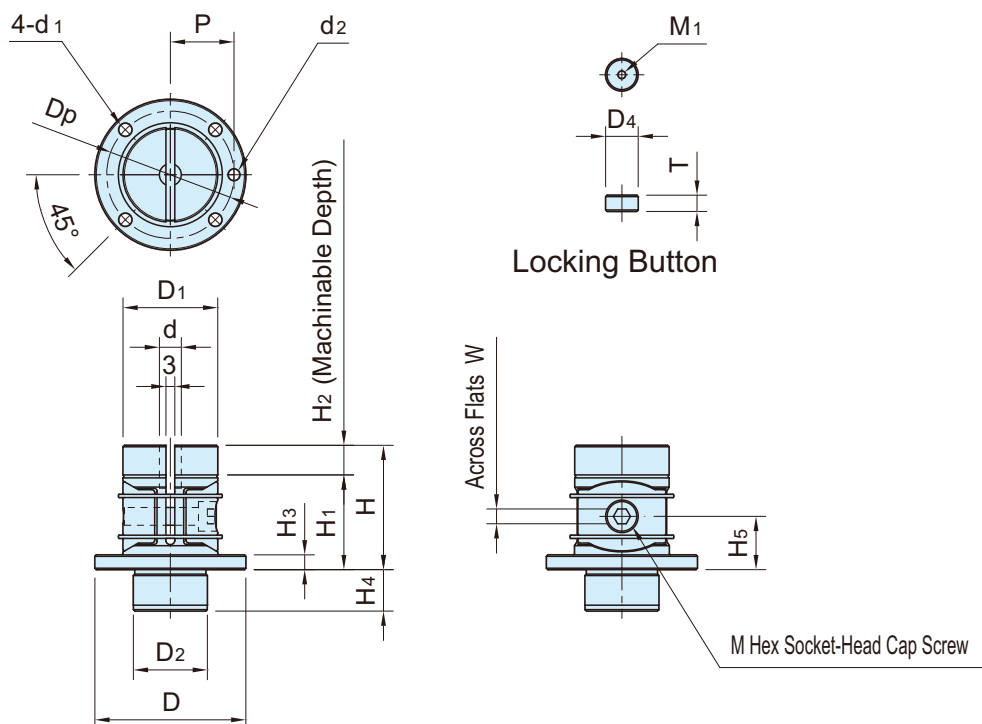

Part Number	D_1	d	H	H_2	D	H_1	H_3	D_2 (g7)	H_4	d_1	D_p	d_2	P
CP123-03201	32	7.4	42	10	51	32	5	25	14	4.5	43	5	21.5
CP123-05001	50	11.4	63	15	75	48	7	40	19	5.5	65	6	32.5

Part Number	M	W	H_5	M_1	D_4	T	Clamping Force (N)	Allowable Screw Torque (N· m)	Weight (kg)
CP123-03201	M 6×1 -25L	5	18	M3×0.5	7	3.5	3,000	9	0.33
CP123-05001	M10×1.5-35L	8	27		11	5.5	7,000	42	1.2

Technical Information

- Locating Repeatability ± 0.08

Furnished Parts

- 1 of locking button
- Spring pin
($\phi 5 \times 10L$ for CP123-03201)
($\phi 6 \times 14L$ for CP123-05001)

Notes:

- Do not tighten the clamping screw without the workpiece set to prevent damage and deformation.
- Do not machine the jaws beyond the machinable depth.

CPI23-OD Holding Clamps (Wedge Style/Round)

Features:

- When the clamp screw is tightened, both jaws tilt toward the center to clamp the circumference of the workpiece.
- The clamping stroke is 0.5mm.
- Cutting the machinable jaw to the contours of parts allows holding parts of different shapes.
- Simple and compact design permits multiple-parts holding arrangement.

How To Use

Mouting-Hole Dimensions

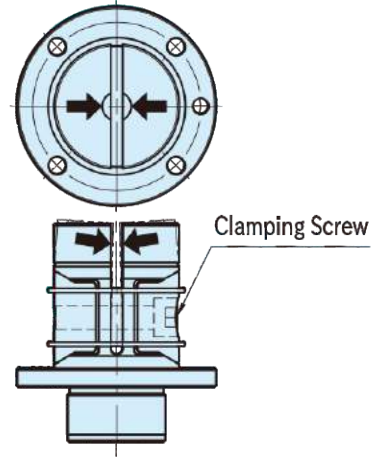
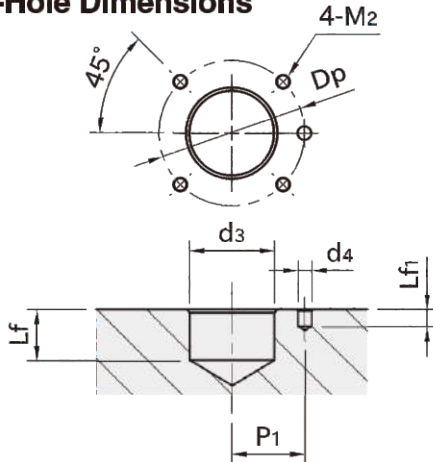

Part Number	d ₃ (H7)	Lf	d ₄ (^{+0.12} ₀)	Lf ₁	P ₁ (±0.05)	M ₂	Dp
CP123-03201	25	15	5	5	21.5	M4×0.7	43
CP123-05001	40	20	6	7	32.5	M5×0.8	65

How To Machine Jaws

① Setting the locking button

Insert the locking button into the jaw, and then tighten the clamp screw to fasten the locking button. (Using a cap screw facilitates setting)

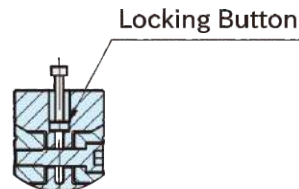
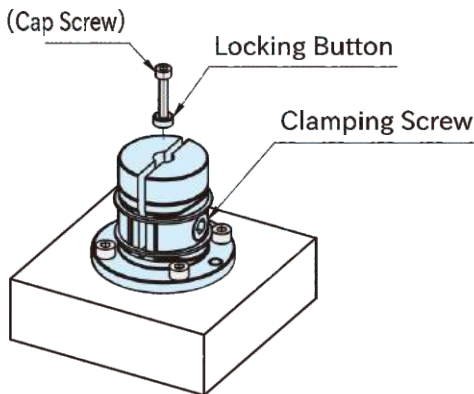

Note: The locking button must be inserted onto the bottom.

② Machining the jaw

Cut the jaw to the contours of the part.

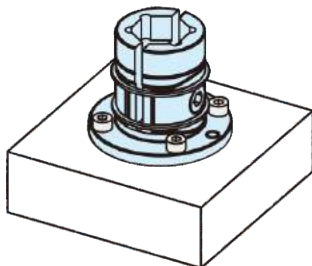

Note: Do not cut beyond the machinable depth.

③ Loading the part

Loosen the clamping screw to remove the locking button. Load the part and tighten the clamping screw for clamping.

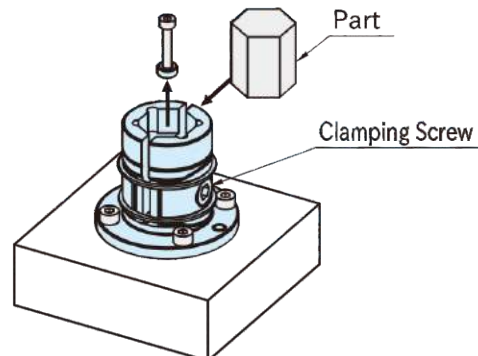

CPI30-ID Holding Clamps

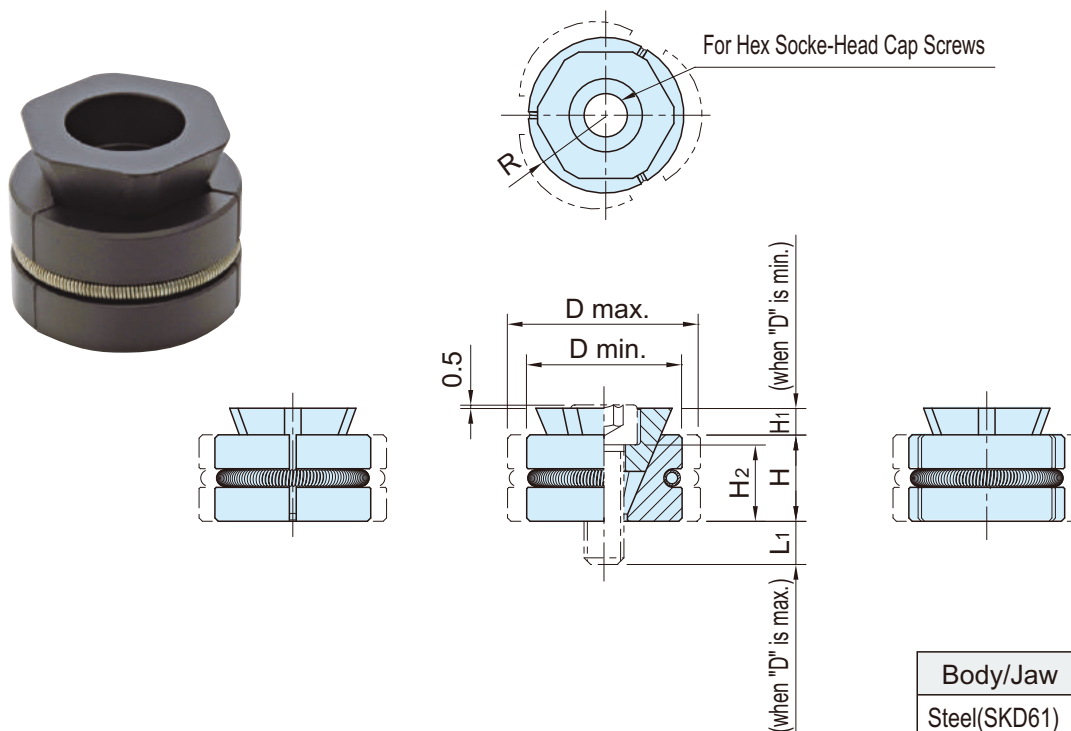

Body/Jaw	Spring
Steel(SKD61) Quenched & tempered(Rc47-53) Black oxide finished	Stainless Steel (SUS304)

Part Number	D		H	H ₁	R	H ₂		L ₁ *)	Proper Cap Screws	Clamping Force (N)
	min.	max.				min.	max.			
CP130-04001	19.5	24	9	2.5	R 9.5	8	2.6	9.4	M4×12L	2,000
CP130-06001	23.5	29	13	4	R11.5	11.5	5	13	M6×18L	5,000
CP130-08001	28.5	36	17	5.5	R14	15	6	19	M8×25L	9,000

Part Number	Allowable Screw Torque (N· m)	Weight (g)
CP130-04001	3.2	17
CP130-06001	10.5	37
CP130-08001	25	75

*) The stated values are only for use of the proper cap screws.

Features

- These clamps hold the inside diameter of the workpiece.
- The wedge construction allows powerfully clamping the workpiece.
- Long clamping stroke is ideal for holding as-cast or roughly-finished holes.

How To Use

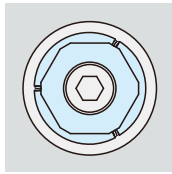
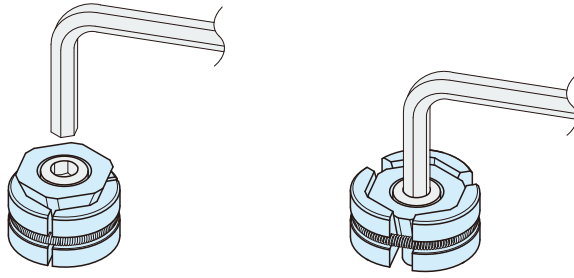

Unclamping Mode

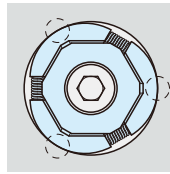

Clamping Mode

Note: The clamp makes a line contact with the workpiece at the clamping mode. This contact can mar the surface of the workpiece depending on its materials, and using these clamps for accurately finished holes is not recommended.

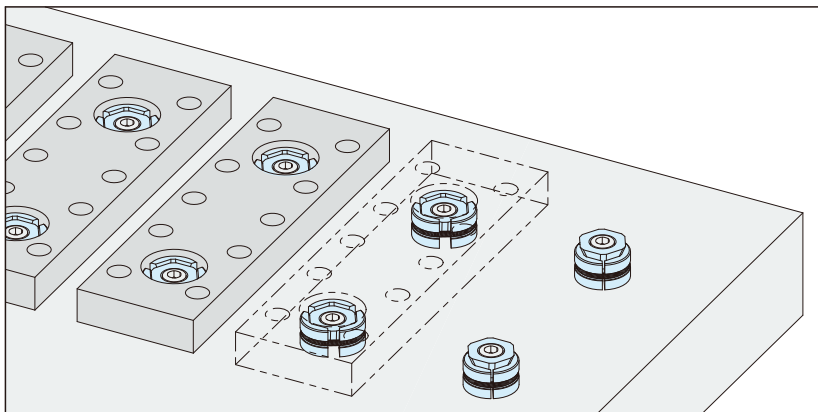

Example of application where two I.D. Holding Clamps are used.

Note

For accurate locating, use these clamps with a locator as shown below.

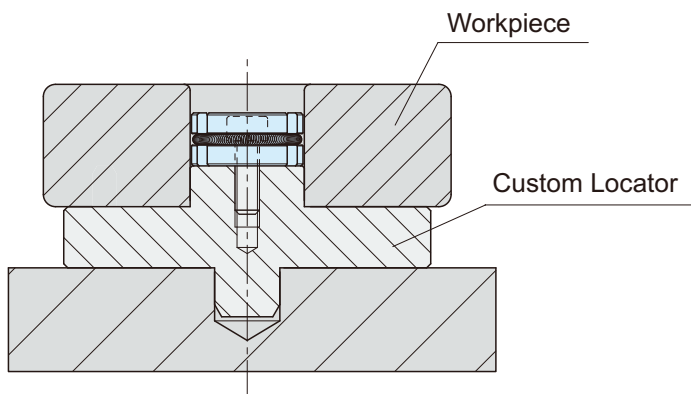

Spring Plunger

with slot and ball, steel

K0309

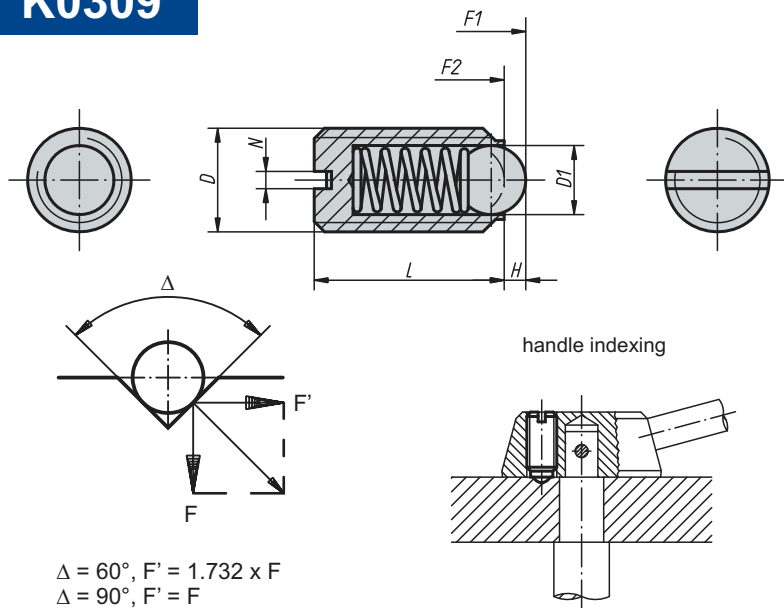

$$\Delta = 60^\circ, F' = 1.732 \times F$$

$$\Delta = 90^\circ, F' = F$$

$$\Delta = 120^\circ, F' = 0.577 \times F$$



Material:
 Body in steel quality class 5.8.
 Ball in steel.
 Spring in spring steel class D.

Surface finish:
 Black oxide finish.
 Ball hardened.

Sample order:
 K0309.203

KIPP Spring plungers with slot and ball, standard spring

Order No.	D	D1	L	H	N	Spring force initial pressure F1 approx. N	Spring force final pressure F2 approx. N	Approx. weight g
K0309.03	M3	1,5	7	0,4	0,4	1,5	3	0,2
K0309.04	M4	2,5	9	0,8	0,6	4	10	0,6
K0309.05	M5	3	12	0,9	0,8	6	11	0,9
K0309.06	M6	3,5	14	1	1	9	13	1,5
K0309.08	M8	5	16	1,5	1,2	15	30	3,5
K0309.10	M10	6	19	2	1,6	20	35	7
K0309.12	M12	8	22	2,5	2	30	55	10
K0309.16	M16	10	24	3,5	2,5	65	125	24
K0309.20	M20	12	30	4,5	2,5	80	160	44,3

KIPP Spring plungers with slot and ball, reinforced spring

Order No.	D	D1	L	H	N	Spring force initial pressure F1 approx. N	Spring force final pressure F2 approx. N	Approx. weight g
K0309.203	M3	1,5	7	0,4	0,4	5	7	0,2
K0309.204	M4	2,5	9	0,8	0,6	12	22	0,6
K0309.205	M5	3	12	0,9	0,8	19	30	0,9
K0309.206	M6	3,5	14	1	1	28	40	1,5
K0309.208	M8	5	16	1,5	1,2	47	73	3,5
K0309.210	M10	6	19	2	1,6	66	100	7
K0309.212	M12	8	22	2,5	2	66	120	10
K0309.216	M16	10	24	3,5	2,5	90	180	24
K0309.220	M20	12	30	4,5	2,5	115	240	44,3

KIPP Spring plungers with slot and ball, long version, standard spring

Order No.	D	D1	L	H	N	Spring force initial pressure F1 approx. N	Spring force final pressure F2 approx. N	Approx. weight g
K0309.404	M4	2,5	16	0,8	0,6	4	10	0,6
K0309.405	M5	3	20	0,9	0,8	6	11	0,9
K0309.406	M6	3,5	25	1	1	9	13	1,5
K0309.408	M8	5	30	1,5	1,2	15	30	3,5
K0309.410	M10	6	35	2	1,6	20	35	7
K0309.412	M12	8	40	2,5	2	30	55	10
K0309.416	M16	10	45	3,5	2,5	65	125	24

Spring Plunger

with slot and ball, stainless steel

K0310

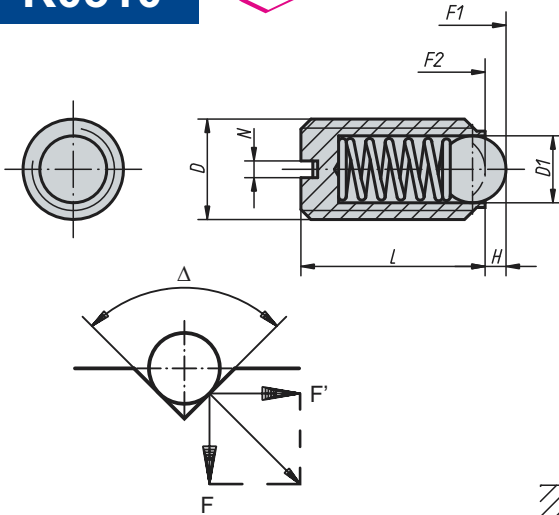

$\Delta = 60^\circ, F' = 1.732 \times F$
 $\Delta = 90^\circ, F' = F$
 $\Delta = 120^\circ, F' = 0.577 \times F$

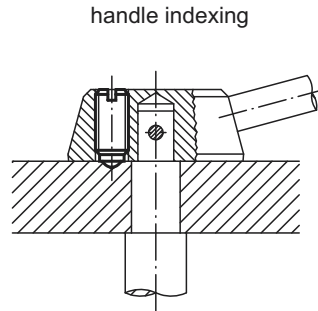

Material:
 Sleeve I.4305.
 Ball I.4034.
 Spring I.4310.

Surface finish:
 Natural finish.
 Ball hardened.

Sample order:
 K0310.203

KIPP Spring plungers with slot and ball, standard spring

Order No.	D	D1	L	H	N	Spring force initial pressure F1 approx. N	Spring force final pressure F2 approx. N	Approx. weight g
K0310.03	M3	1,5	7	0,4	0,4	1,5	3	0,2
K0310.04	M4	2,5	9	0,8	0,6	4	10	0,6
K0310.05	M5	3	12	0,9	0,8	6	11	0,9
K0310.06	M6	3,5	14	1	1	9	13	1,5
K0310.08	M8	5	16	1,5	1,2	15	30	3,5
K0310.10	M10	6	19	2	1,6	20	35	7
K0310.12	M12	8	22	2,5	2	30	55	10
K0310.16	M16	10	24	3,5	2,5	65	125	24
K0310.20	M20	12	30	4,5	2,5	80	160	44,3

KIPP Spring plungers with slot and ball, reinforced spring

Order No.	D	D1	L	H	N	Spring force initial pressure F1 approx. N	Spring force final pressure F2 approx. N	Approx. weight g
K0310.203	M3	1,5	7	0,4	0,4	5	7	0,2
K0310.204	M4	2,5	9	0,8	0,6	12	22	0,6
K0310.205	M5	3	12	0,9	0,8	19	30	0,9
K0310.206	M6	3,5	14	1	1	28	40	1,5
K0310.208	M8	5	16	1,5	1,2	47	73	3,5
K0310.210	M10	6	19	2	1,6	66	100	7
K0310.212	M12	8	22	2,5	2	66	120	10
K0310.216	M16	10	24	3,5	2,5	90	180	24
K0310.220	M20	12	30	4,5	2,5	115	240	44,3

KIPP Spring plungers with slot and ball, long version, standard spring

Order No.	D	D1	L	H	N	Spring force initial pressure F1 approx. N	Spring force final pressure F2 approx. N	Approx. weight g
K0310.404	M4	2,5	16	0,8	0,6	4	10	0,6
K0310.405	M5	3	20	0,9	0,8	6	11	0,9
K0310.406	M6	3,5	25	1	1	9	13	1,5
K0310.408	M8	5	30	1,5	1,2	15	30	3,5
K0310.410	M10	6	35	2	1,6	20	35	7
K0310.412	M12	8	40	2,5	2	30	55	10
K0310.416	M16	10	45	3,5	2,5	65	125	24

Spring Plunger with slot and POM ball

K0311

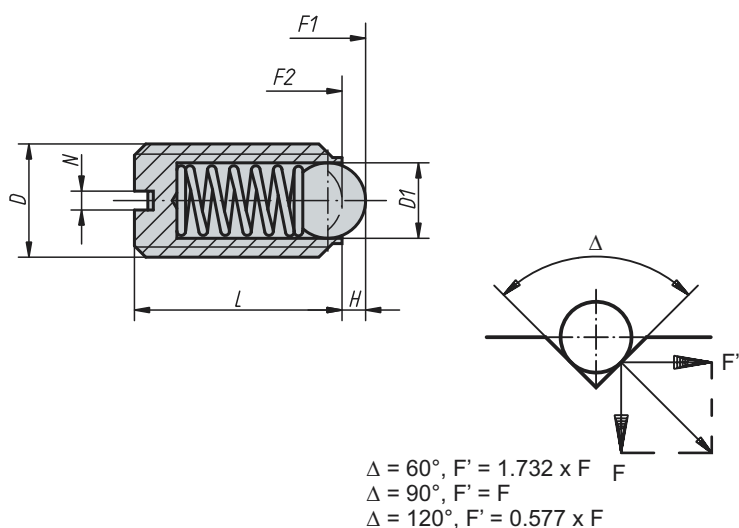

Material, surface finish:
Sleeve in plastic.
Ball in white POM.
Spring I.4310.

Sample order:
K0311.10

Note:
Spring plungers are used for indexing and positioning. They can also be used as ejectors.

KIPP Spring plungers with slot and POM ball

Order No.	D	D1	L	H	N	Spring force initial pressure F1 approx. N	Spring force final pressure F2 approx. N	Approx. weight g
K0311.06	M6	3,5	14	1	1	9	13	0,4
K0311.08	M8	5	16	1,5	1,2	15	30	0,8
K0311.10	M10	6	19	2	1,6	20	40	1,6

Spring plungers

with slot and stainless steel ball

K0312

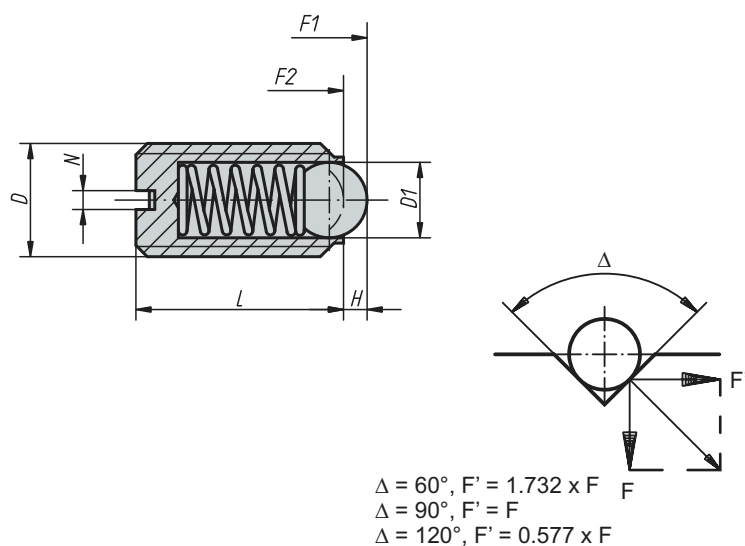

Material, surface finish:
Sleeve in plastic.
Ball in stainless steel I.4034, hardened.
Spring I.4310.

Sample order:
K0312.10

Note:
Spring plungers are used for indexing and positioning. They can also be used as ejectors.

KIPP Spring plungers with slot and stainless steel ball

Order No.	D	D1	L	H g	N	Spring force initial pressure F1 approx. N	Spring force initial pressure F2 approx. N	Approx. weight g
K0312.06	M6	3,5	14	1	1	9	13	0,6
K0312.08	M8	5	16	1,5	1,2	15	30	1,2
K0312.10	M10	6	19	2	1,6	20	40	2,3

Spring Plunger

with slot and ceramic ball, stainless steel

K0609

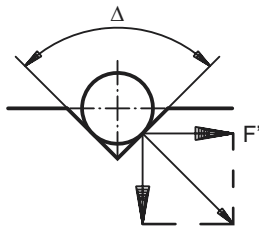
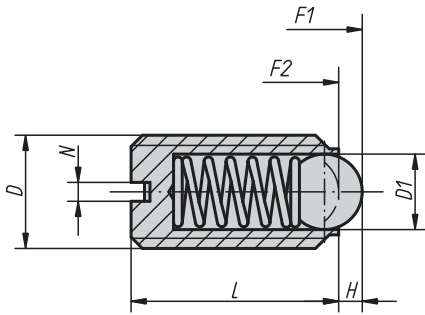

$\Delta = 60^\circ, F' = 1.732 \times F$
 $\Delta = 90^\circ, F' = F$
 $\Delta = 120^\circ, F' = 0.577 \times F$

Material:
 Sleeve 1.4305.
 Ceramic ball Si₃N₄.
 Spring 1.4310.

Surface finish:
 Natural finish

Sample order:
 K0609.05

Note:
 The combination of excellent material properties is a special feature of silicon Nitride (Si₃N₄). These include, for example, high tenacity and stability, excellent wear resistance and efficient chemical resistance.

KIPP Spring plungers with slot and ceramic ball, stainless steel

Order No.	D	D1	L	H	N	Spring force initial pressure F1 approx. N	Spring force final pressure F2 approx. N	Approx. weight g
K0609.05	M5	3	12	0,9	0,8	6	11	0,9
K0609.06	M6	3,5	14	1	1	9	13	1,5
K0609.08	M8	5	16	1,5	1,2	15	30	3,5
K0609.10	M10	6	19	2	1,6	20	35	7
K0609.12	M12	8	22	2,5	2	30	55	10
K0609.16	M16	10	24	3,5	2,5	65	125	24

Spring Plunger

with slot and pressure pin, steel

K0313

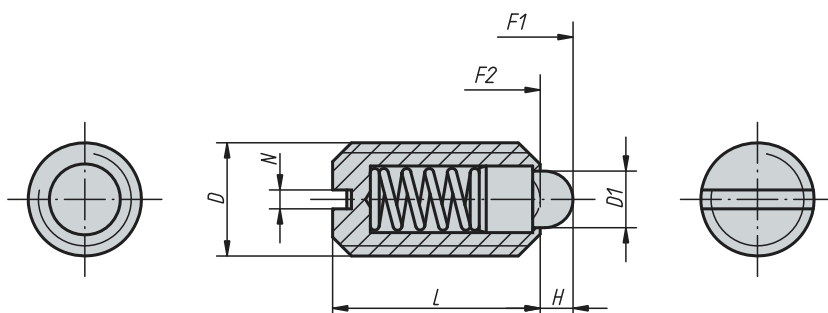

Material:
 Body in steel quality class 5.8.
 Pressure pin in steel.
 Spring in spring steel class D.

Surface finish:
 Black oxide finish.
 Pressure pin hardened.

Sample order:
 K0313.10

KIPP Spring plungers with slot and pressure pin, standard spring

Order No.	D	D1	L	H	N	Spring force initial pressure F1 approx. N	Spring force final pressure F2 approx. N	Approx. weight g
K0313.04	M4	1,8	9	1,5	0,6	6	20	0,39
K0313.05	M5	2,4	12	2	0,8	6	20	1
K0313.06	M6	2,7	14	2	1	7	20	1,7
K0313.08	M8	4	16	2	1,2	15	30	4
K0313.10	M10	4,5	19	2,5	1,6	20	35	7
K0313.12	M12	6	22	3,5	2	30	55	13
K0313.16	M16	8,5	24	4,5	2,5	45	100	24
K0313.20	M20	10	30	6,5	2,5	60	120	46,3

KIPP Spring plungers with slot and pressure pin, light spring

Order No.	D	D1	L	H	N	Spring force initial pressure F1 approx. N	Spring force final pressure F2 approx. N	Approx. weight g
K0313.104	M4	1,8	9	1,5	0,6	3	10	0,39
K0313.105	M5	2,4	12	2	0,8	3	10	1
K0313.106	M6	2,7	14	2	1	4	10	1,7
K0313.108	M8	4	16	2	1,2	7	15	4
K0313.110	M10	4,5	19	2,5	1,6	9	16	7
K0313.112	M12	6	22	3,5	2	14	26	13
K0313.116	M16	8,5	24	4,5	2,5	22	50	24
K0313.120	M20	10	30	6,5	2,5	30	60	46,3

KIPP Spring plungers with slot and pressure pin, reinforced spring

Order No.	D	D1	L	H	N	Spring force initial pressure F1 approx. N	Spring force final pressure F2 approx. N	Approx. weight g
K0313.205	M5	2,4	12	2	0,8	9	25	1
K0313.206	M6	2,7	14	2	1	11	25	1,7
K0313.208	M8	4	16	2	1,2	22	43	4
K0313.210	M10	4,5	19	2,5	1,6	20	54	7
K0313.212	M12	6	22	3,5	2	36	94	13
K0313.216	M16	8,5	24	4,5	2,5	60	110	24

Spring Plunger

with slot and pressure pin, stainless steel

K0314

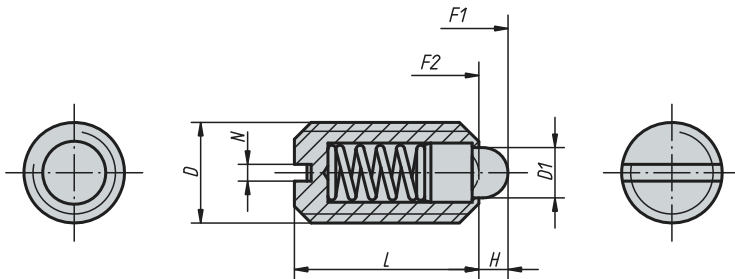

Material:
Sleeve 1.4305.
Pressure pin 1.4034.
Spring 1.4310.

Surface finish:
Natural finish.
Pressure pin hardened.

Sample order:
K0314.10

KIPP Spring plungers with slot and pressure pin, standard spring

Order No.	D	D1	L	H	N	Spring force initial pressure F1 approx. N	Spring force final pressure F2 approx. N	Approx. weight g
K0314.04	M4	1,8	9	1,5	0,6	6	20	0,39
K0314.05	M5	2,4	12	2	0,8	6	20	1
K0314.06	M6	2,7	14	2	1	7	20	1,7
K0314.08	M8	4	16	2	1,2	15	30	4
K0314.10	M10	4,5	19	2,5	1,6	20	35	7
K0314.12	M12	6	22	3,5	2	30	55	13
K0314.16	M16	8,5	24	4,5	2,5	45	100	24
K0314.20	M20	10	30	6,5	2,5	60	120	46,3

KIPP Spring plungers with slot and pressure pin, light spring

Order No.	D	D1	L	H	N	Spring force initial pressure F1 approx. N	Spring force final pressure F2 approx. N	Approx. weight g
K0314.104	M4	1,8	9	1,5	0,6	3	10	0,39
K0314.105	M5	2,4	12	2	0,8	3	10	1
K0314.106	M6	2,7	14	2	1	4	10	1,7
K0314.108	M8	4	16	2	1,2	7	15	4
K0314.110	M10	4,5	19	2,5	1,6	9	16	7
K0314.112	M12	6	22	3,5	2	14	26	13
K0314.116	M16	8,5	24	4,5	2,5	22	50	24
K0314.120	M20	10	30	6,5	2,5	30	60	46,3

KIPP Spring plungers with slot and pressure pin, reinforced spring

Order No.	D	D1	L	H	N	Spring force initial pressure F1 approx. N	Spring force final pressure F2 approx. N	Approx. weight g
K0314.205	M5	2,4	12	2	0,8	9	25	1
K0314.206	M6	2,7	14	2	1	11	25	1,7
K0314.208	M8	4	16	2	1,2	22	43	4
K0314.210	M10	4,5	19	2,5	1,6	20	54	7
K0314.212	M12	6	22	3,5	2	36	94	13
K0314.216	M16	8,5	24	4,5	2,5	60	110	24

Spring Plunger

with hexagon socket and ball, steel

K0315

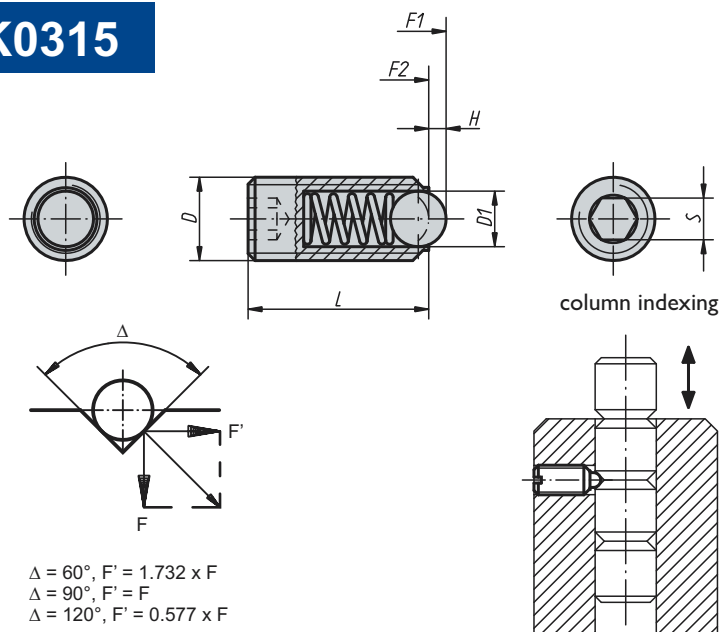

$\Delta = 60^\circ, F' = 1.732 \times F$
 $\Delta = 90^\circ, F' = F$
 $\Delta = 120^\circ, F' = 0.577 \times F$



Material:
 Body in steel quality class 5.8.
 Ball in steel.
 Spring in spring steel class D.

Surface finish:
 Black oxide finish.
 Ball hardened.

Sample order:
 K0315.210

KIPP Spring plungers with hexagon socket and ball, standard spring force

Order No.	D	D1	L	H	N	Spring force initial pressure F1 approx. N	Spring force final pressure F2 approx. N	Approx. weight g
K0315.03	M3	1,5	9	0,4	1,5	1,5	3	0,23
K0315.04	M4	2,5	10	0,8	2	4	10	0,46
K0315.05	M5	3	14	0,9	2,5	6	11	1,27
K0315.06	M6	3,5	15	1	3	9	13	2
K0315.08	M8	5	18	1,5	4	15	30	4
K0315.10	M10	6	23	2	5	20	35	8
K0315.12	M12	8	26	2,5	6	30	55	12
K0315.16	M16	10	33	3,5	8	65	125	31
K0315.20	M20	12	43	4,5	10	80	160	64
K0315.24	M24	15	48	5,5	12	90	180	100

KIPP Spring plungers with hexagon socket and ball, strong spring force

Order No.	D	D1	L	H	N	Spring force initial pressure F1 approx. N	Spring force final pressure F2 approx. N	Approx. weight g
K0315.203	M3	1,5	9	0,4	1,5	5	7	0,23
K0315.204	M4	2,5	10	0,8	2	12	22	0,46
K0315.205	M5	3	14	0,9	2,5	19	30	1,27
K0315.206	M6	3,5	15	1	3	28	40	2
K0315.208	M8	5	18	1,5	4	47	73	4
K0315.210	M10	6	23	2	5	66	100	8
K0315.212	M12	8	26	2,5	6	66	120	12
K0315.216	M16	10	33	3,5	8	90	180	31
K0315.220	M20	12	43	4,5	10	115	240	64
K0315.224	M24	15	48	5,5	12	130	270	100

KIPP Spring plungers with hexagon socket and ball, long version, standard spring force

Order No.	D	D1	L	H	N	Spring force initial pressure F1 approx. N	Spring force final pressure F2 approx. N	Approx. weight g
K0315.404	M4	2,5	16	0,8	2	4	10	0,89
K0315.405	M5	3	20	0,9	2,5	6	11	1,82
K0315.406	M6	3,5	25	1	3	9	13	3,37
K0315.408	M8	5	30	1,5	4	15	30	7,36
K0315.410	M10	6	35	2	5	20	35	13,52
K0315.412	M12	8	40	2,5	6	30	55	21,61
K0315.416	M16	10	45	3,5	8	65	125	46,56

Spring Plunger

with hexagon socket and ball, stainless steel

K0316

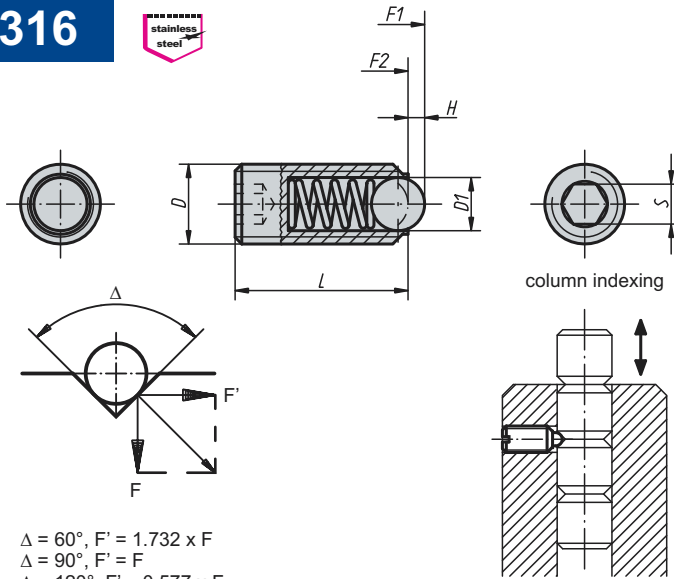

$\Delta = 60^\circ, F' = 1.732 \times F$
 $\Delta = 90^\circ, F' = F$
 $\Delta = 120^\circ, F' = 0.577 \times F$



Material:
 Sleeve I.4305.
 Ball I.4034.
 Spring I.4310.

Surface finish:
 Natural finish.
 Ball hardened.

Sample order:
 K0316.210

KIPP Spring plungers with hexagon socket and ball, standard spring force

Order No.	D	D1	L	H	N	Spring force initial pressure F1 approx. N	Spring force final pressure F2 approx. N	Approx. weight g
K0316.03	M3	1,5	9	0,4	1,5	1,5	3	0,23
K0316.04	M4	2,5	10	0,8	2	4	10	0,46
K0316.05	M5	3	14	0,9	2,5	6	11	1,27
K0316.06	M6	3,5	15	1	3	9	13	2
K0316.08	M8	5	18	1,5	4	15	30	4
K0316.10	M10	6	23	2	5	20	35	8
K0316.12	M12	8	26	2,5	6	30	55	12
K0316.16	M16	10	33	3,5	8	65	125	31
K0316.20	M20	12	43	4,5	10	80	160	64
K0316.24	M24	15	48	5,5	12	90	180	100

KIPP Spring plungers with hexagon socket and ball, strong spring force

Order No.	D	D1	L	H	N	Spring force initial pressure F1 approx. N	Spring force final pressure F2 approx. N	Approx. weight g
K0316.203	M3	1,5	9	0,4	1,5	5	7	0,23
K0316.204	M4	2,5	10	0,8	2	12	22	0,46
K0316.205	M5	3	14	0,9	2,5	19	30	1,27
K0316.206	M6	3,5	15	1	3	28	40	2
K0316.208	M8	5	18	1,5	4	47	73	4
K0316.210	M10	6	23	2	5	66	100	8
K0316.212	M12	8	26	2,5	6	66	120	12
K0316.216	M16	10	33	3,5	8	90	180	31
K0316.220	M20	12	43	4,5	10	115	240	64
K0316.224	M24	15	48	5,5	12	130	270	100

KIPP Spring plungers with hexagon socket and ball, long version, standard spring force

Order No.	D	D1	L	H	N	Spring force initial pressure F1 approx. N	Spring force final pressure F2 approx. N	Approx. weight g
K0316.404	M4	2,5	16	0,8	2	4	10	0,89
K0316.405	M5	3	20	0,9	2,5	6	11	1,82
K0316.406	M6	3,5	25	1	3	9	13	3,37
K0316.408	M8	5	30	1,5	4	15	30	7,36
K0316.410	M10	6	35	2	5	20	35	13,52
K0316.412	M12	8	40	2,5	6	30	55	21,61
K0316.416	M16	10	45	3,5	8	65	125	46,56

Spring Plunger

with hexagon socket and ceramic ball

K0610

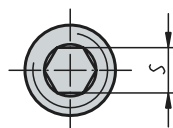
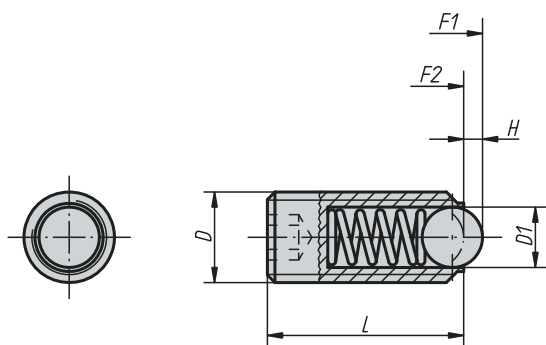

Material:
Sleeve 1.4305.
Ceramic ball Si₃N₄
Spring 1.4310.

Surface finish:
Natural finish.

Sample order:
K0610.05

Note:
The combination of excellent material properties is a special feature of silicon nitride(Si₃N₄).These include, for example, high tenacity and stability, excellent wear resistance and efficient chemical resistance.

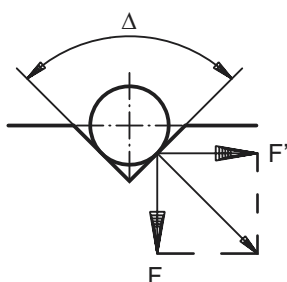

$\Delta = 60^\circ, F' = 1.732 \times F$
 $\Delta = 90^\circ, F' = F$
 $\Delta = 120^\circ, F' = 0.577 \times F$

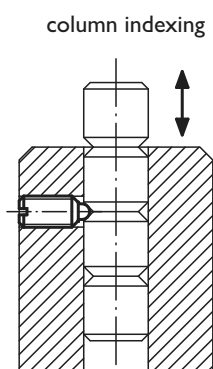

KIPP Spring plungers with hexagon socket and ceramic ball

Order No.	D	D1	L	H	N	Spring force initial pressure F1 approx. N	Spring force final pressure F2 approx. N	Approx. weight g
K0610.05	M5	3	14	0,9	2,5	6	11	1,3
K0610.06	M6	3,5	15	1	3	9	13	2
K0610.08	M8	5	18	1,5	4	15	30	4
K0610.10	M10	6	23	2	5	20	35	8
K0610.12	M12	8	26	2,5	6	30	55	12
K0610.16	M16	10	33	3,5	8	65	125	31

Spring Plunger

with hexagon socket and pressure pin, long version

K0657

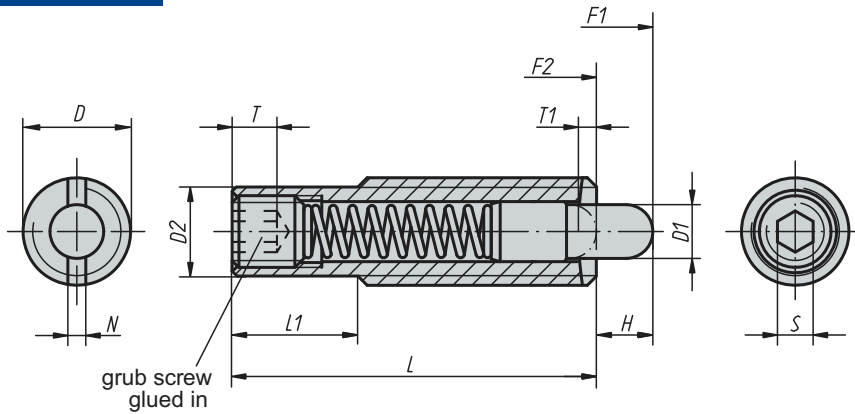

assembly key

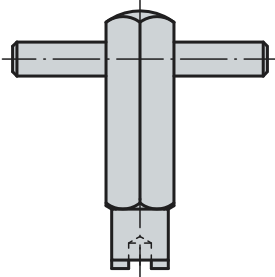
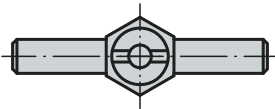

Material:
Sleeve in steel quality class 5.8.
Pressure pin in steel.
Spring in spring steel D.

Surface finish:
Black oxide finish.
Pressure pin hardened.

Sample order:
K0657.616

Note:
These spring plungers are chiefly used as ejectors and spring stops in machine construction.

bending the shank

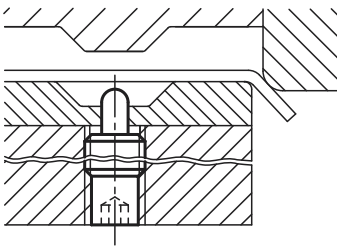

forming

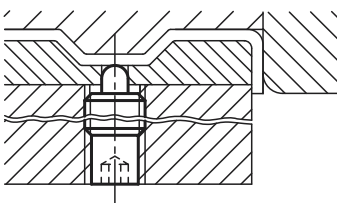

KIPP Spring plungers with hexagon socket and pressure pin, long version

Order No.	D	D1	D2	L	L1	H	T	T1	N	S	Spring force initial pressure F1 approx. N	Spring force final pressure F2 approx. N	Order No. assembly key
K0657.608	M8	3,5	6,2	30	10	6	2	1,4	1,2	2,5	8	22	K0317.908
K0657.610	M10	4	8	40	10	8	3	1,4	1,6	3	12	30	K0317.910
K0657.612	M12	6	9,6	50	20	10	5	2	2	4	20	50	K0317.912
K0657.616	M16	7,5	13,4	60	30	12	6	2,5	2,5	5	30	64	K0317.916

Spring Plunger

with hexagon socket and pressure pin, steel

K0317

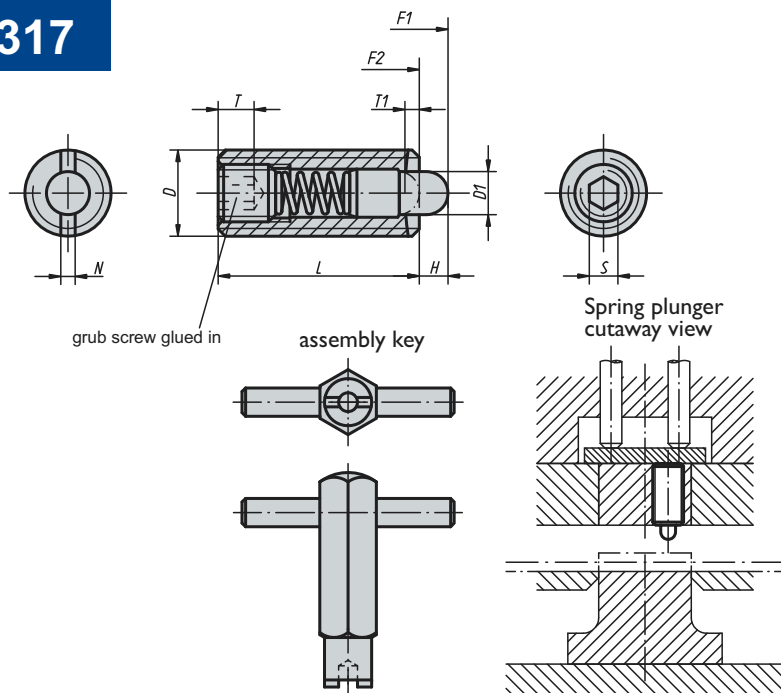

Material:
 Body in steel quality class 5.8.
 Pressure pin in steel.
 Spring in spring steel class D.

Surface finish:
 Black oxide finish.
 Pressure pin hardened.

Sample order:
 K0317.16

KIPP Spring plungers with hexagon socket and pressure pin, standard spring force

Order No.	D	D1	L	H	T	T1	N	S	Spring force initial pressure F1 approx. N	Spring force final pressure F2 approx. N	Approx. weight g	Order No. assembly key
K0317.03	M3	1	10	1,5	1,5	1	0,4	0,7	0,5	3	0,35	K0317.903
K0317.04	M4	1,5	15	1,5	2	0,6	0,6	1,3	5	16	0,8	K0317.904
K0317.05	M5	2,4	18	2,3	2	0,8	0,8	1,5	6	20	1,3	K0317.905
K0317.06	M6	2,7	20	2,5	2,5	1	1	2	7	20	2,5	K0317.906
K0317.08	M8	3,5	22	3	3	1,4	1,2	2,5	9	35	6	K0317.908
K0317.10	M10	4	22	3	3,5	1,4	1,6	3	9	35	9	K0317.910
K0317.12	M12	6	28	4	5	2	2	4	10	55	16	K0317.912
K0317.16	M16	7,5	32	5	6	2,5	2,5	5	45	100	35	K0317.916
K0317.20	M20	10	40	7	8	3	2,5	6	60	120	66,3	-
K0317.24	M24	12	52	10	10	3	2,5	8	80	160	122,2	-

KIPP Spring plungers with hexagon socket and pressure pin, light spring force

Order No.	D	D1	L	H	T	T1	N	S	Spring force initial pressure F1 approx. N	Spring force final pressure F2 approx. N	Approx. weight g	Order No. assembly key
K0317.104	M4	1,5	15	1,5	2	0,6	0,6	1,3	2	7	0,8	K0317.904
K0317.105	M5	2,4	18	2,3	2	0,8	0,8	1,5	3	10	1,3	K0317.905
K0317.106	M6	2,7	20	2,5	2,5	1	1	2	3	9	2,5	K0317.906
K0317.108	M8	3,5	22	3	3	1,4	1,2	2,5	4	16	6	K0317.908
K0317.110	M10	4	22	3	3,5	1,4	1,6	3	4	16	9	K0317.910
K0317.112	M12	6	28	4	5	2	2	4	5	27	16	K0317.912
K0317.116	M16	7,5	32	5	6	2,5	2,5	5	20	45	35	K0317.916

KIPP Spring plungers with hexagon socket and pressure pin, strong spring force

Order No.	D	D1	L	H	T	T1	N	S	Spring force initial pressure F1 approx. N	Spring force final pressure F2 approx. N	Approx. weight g	Order No. assembly key
K0317.205	M5	2,4	18	2,3	2	0,8	0,8	1,5	11	29	1,3	K0317.905
K0317.206	M6	2,7	20	2,5	2,5	1	1	2	14	37	2,5	K0317.906
K0317.208	M8	3,5	22	3	3	1,4	1,2	2,5	22	65	6	K0317.908
K0317.210	M10	4	22	3	3,5	1,4	1,6	3	19	70	9	K0317.910
K0317.212	M12	6	28	4	5	2	2	4	25	85	16	K0317.912
K0317.216	M16	7,5	32	5	6	2,5	2,5	5	60	150	35	K0317.916
K0317.220	M20	10	40	7	8	3	2,5	6	75	190	66,3	-
K0317.224	M24	12	52	10	10	3	2,5	8	95	240	122,2	-

Spring Plunger

with hexagon socket and pressure pin, stainless steel

K0319

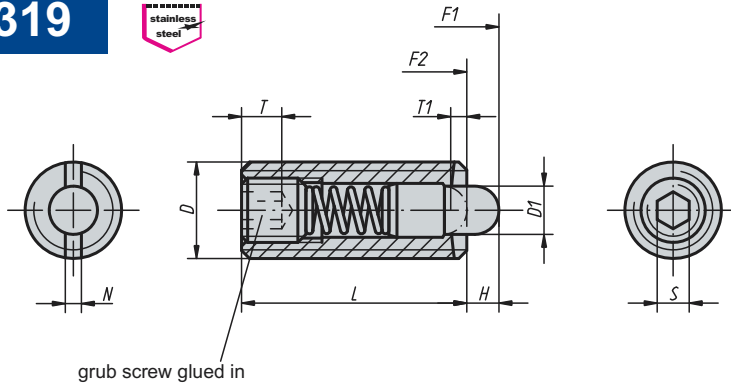

Material:
Sleeve 1.4305.
Pressure pin 1.4034.
Spring 1.4310.

Surface finish:
Natural finish.
Pressure pin hardened.

Sample order:
K0319.16

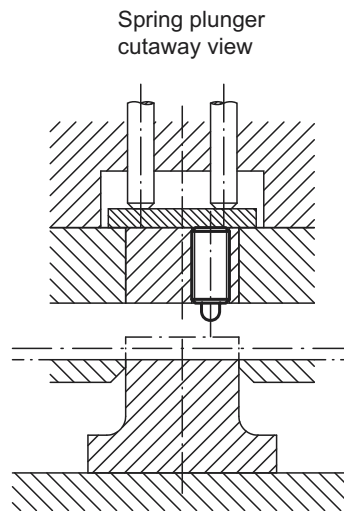
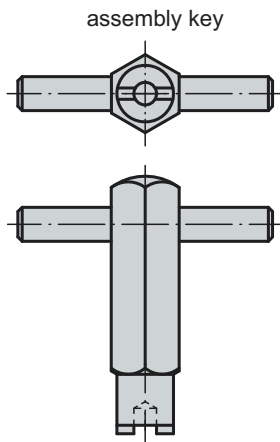

KIPP Spring plungers with hexagon socket and pressure pin, standard spring force

Order No.	D	D1	L	H	T	T1	N	S	Spring force initial pressure F1 approx. N	Spring force final pressure F2 approx. N	Approx. weight g	Order No. assembly key
K0319.03	M3	1	10	1,5	1,5	1	0,4	0,7	0,5	3	0,35	K0317.903
K0319.04	M4	1,5	15	1,5	2	0,6	0,6	1,3	5	16	0,8	K0317.904
K0319.05	M5	2,4	18	2,3	2	0,8	0,8	1,5	5	17	1,3	K0317.905
K0319.06	M6	2,7	20	2,5	2,5	1	1	2	6	17	2,5	K0317.906
K0319.08	M8	3,5	22	3	3	1,4	1,2	2,5	7	29	6	K0317.908
K0319.10	M10	4	22	3	3,5	1,4	1,6	3	8	31	9	K0317.910
K0319.12	M12	6	28	4	5	2	2	4	10	47	16	K0317.912
K0319.16	M16	7,5	32	5	6	2,5	2,5	5	45	100	35	K0317.916

KIPP Spring plungers with hexagon socket and pressure pin, strong spring force

Order No.	D	D1	L	H	T	T1	N	S	Spring force initial pressure F1 approx. N	Spring force final pressure F2 approx. N	Approx. weight g	Order No. assembly key
K0319.205	M5	2,4	18	2,3	2	0,8	0,8	1,5	9	26	1,3	K0317.905
K0319.206	M6	2,7	20	2,5	2,5	1	1	2	11	35	2,5	K0317.906
K0319.208	M8	3,5	22	3	3	1,4	1,2	2,5	15	48	6	K0317.908
K0319.210	M10	4	22	3	3,5	1,4	1,6	3	15	58	9	K0317.910
K0319.212	M12	6	28	4	5	2	2	4	19	74	16	K0317.912

Spring Plunger

with slot and ball, steel, LONG-LOCK secured

K0321

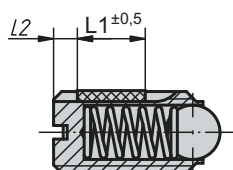
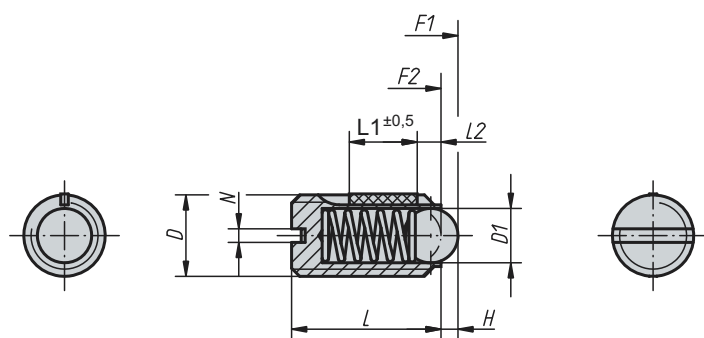

applies to models with
D = M3, M4, M5 and M6

L2 = approx. 2x thread pitch

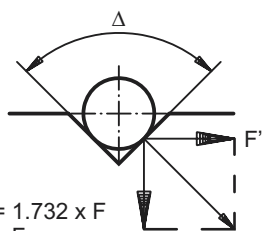

$\Delta = 60^\circ, F' = 1.732 \times F$
 $\Delta = 90^\circ, F' = F$
 $\Delta = 120^\circ, F' = 0.577 \times F$



Material:
 Body in steel quality class 5.8.
 Ball in steel.
 Spring in spring steel class D.

LONG-LOCK thread lock in nylon.

Surface finish:
 Black oxide finish.
 Ball hardened.

Sample order:
 K0321.12

KIPP Spring plungers with slot and ball, standard spring, LONG-LOCK secured

Order No.	D	D1	L	L1	H	N	Spring force initial pressure F1 approx. N	Spring force final pressure F2 approx. N	Tightening torque approx. Nm	Loosening torque, after third unscrewing approx. Nm	Approx. weight g
K0321.03	M3	1,5	7	4	0,4	0,4	1,5	3	0,10	0,07	0,2
K0321.04	M4	2,5	9	5	0,8	0,6	4	10	0,18	0,12	0,6
K0321.05	M5	3	12	6	0,9	0,8	6	11	0,12	0,08	0,9
K0321.06	M6	3,5	14	7	1	1	9	13	0,43	0,21	1,5
K0321.08	M8	5	16	8	1,5	1,2	15	30	1,09	0,37	3,5
K0321.10	M10	6	19	9	2	1,6	20	35	1,36	0,62	7
K0321.12	M12	8	22	10	2,5	2	30	55	2,03	1,36	10
K0321.16	M16	10	24	14	3,5	2,5	65	125	3,95	2,95	24

KIPP Spring plungers with slot and ball, strong spring, LONG-LOCK secured

Order No.	D	D1	L	L1	H	N	Spring force initial pressure F1 approx. N	Spring force final pressure F2 approx. N	Tightening torque approx. Nm	Loosening torque, after third unscrewing approx. Nm	Approx. weight g
K0321.203	M3	1,5	7	4	0,4	0,4	5	7	0,10	0,07	0,2
K0321.204	M4	2,5	9	5	0,8	0,6	12	22	0,18	0,12	0,6
K0321.205	M5	3	12	6	0,9	0,8	19	30	0,12	0,08	0,9
K0321.206	M6	3,5	14	7	1	1	28	40	0,43	0,21	1,5
K0321.208	M8	5	16	8	1,5	1,2	47	73	1,09	0,37	3,5
K0321.210	M10	6	19	9	2	1,6	66	100	1,36	0,62	7
K0321.212	M12	8	22	10	2,5	2	66	120	2,03	1,36	10
K0321.216	M16	10	24	14	3,5	2,5	90	180	3,95	2,95	24

Spring Plunger

with slot and ball, stainless steel, LONG-LOK secured

K0322

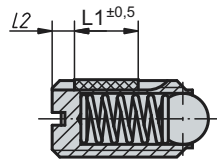
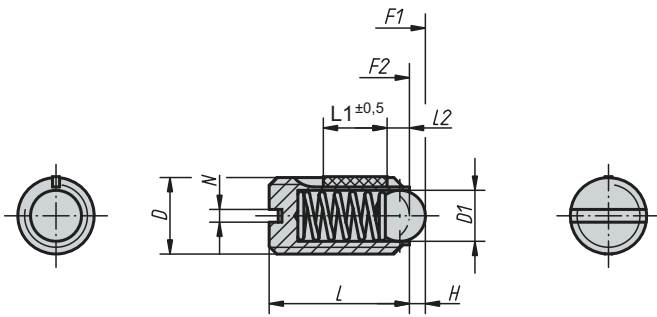

L2 = approx. 2x thread pitch

applies to models with
D = M3, M4, M5 and M6



Material:
Sleeve I.4305.
Ball I.4034.
Spring I.4310.

LONG-LOK thread lock in nylon.

Surface finish:
Natural finish.
Ball hardened.

Sample order:
K0322.12

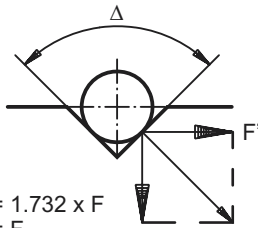

$\Delta = 60^\circ, F' = 1.732 \times F$
 $\Delta = 90^\circ, F' = F$
 $\Delta = 120^\circ, F' = 0.577 \times F$

KIPP Spring plungers with slot and ball, standard spring, LONG-LOK secured

Order No.	D	D1	L	L1	H	N	Spring force initial pressure F1 approx. N	Spring force final pressure F2 approx. N	Tightening torque approx. Nm	Loosening torque, after third unscrewing approx. Nm	Approx. weight g
K0322.03	M3	1,5	7	4	0,4	0,4	1,5	3	0,10	0,07	0,2
K0322.04	M4	2,5	9	5	0,8	0,6	4	10	0,18	0,12	0,6
K0322.05	M5	3	12	6	0,9	0,8	6	11	0,12	0,08	0,9
K0322.06	M6	3,5	14	7	1	1	9	13	0,43	0,21	1,5
K0322.08	M8	5	16	8	1,5	1,2	15	30	1,09	0,37	3,5
K0322.10	M10	6	19	9	2	1,6	20	35	1,36	0,62	7
K0322.12	M12	8	22	10	2,5	2	30	55	2,03	1,36	10
K0322.16	M16	10	24	14	3,5	2,5	65	125	3,95	2,95	24

KIPP Spring plungers with slot and ball, strong spring, LONG-LOK secured

Order No.	D	D1	L	L1	H	N	Spring force initial pressure F1 approx. N	Spring force final pressure F2 approx. N	Tightening torque approx. Nm	Loosening torque, after third unscrewing approx. Nm	Approx. weight g
K0322.203	M3	1,5	7	4	0,4	0,4	5	7	0,10	0,07	0,2
K0322.204	M4	2,5	9	5	0,8	0,6	12	22	0,18	0,12	0,6
K0322.205	M5	3	12	6	0,9	0,8	19	30	0,12	0,08	0,9
K0322.206	M6	3,5	14	7	1	1	28	40	0,43	0,21	1,5
K0322.208	M8	5	16	8	1,5	1,2	47	73	1,09	0,37	3,5
K0322.210	M10	6	19	9	2	1,6	66	100	1,36	0,62	7
K0322.212	M12	8	22	10	2,5	2	66	120	2,03	1,36	10
K0322.216	M16	10	24	14	3,5	2,5	90	180	3,95	2,95	24

Spring Plunger

with slot and pressure pin, steel, LONG-LOK secured

K0323

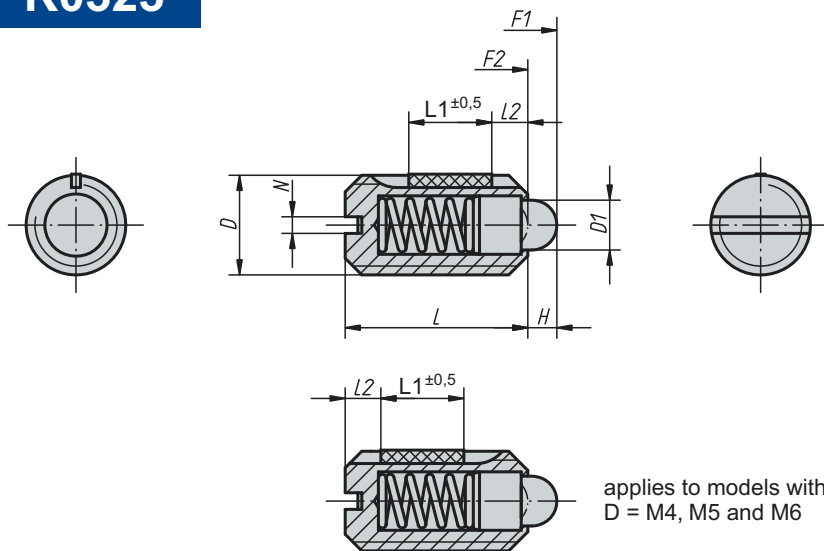

L2 = approx. 2x thread pitch

applies to models with
D = M4, M5 and M6



Material:
Body in steel quality class 5.8.
Pressure pin in steel.
Spring in spring steel class D.

LONG-LOK thread lock in nylon.

Surface finish:
Black oxide finish.
Pressure pin hardened.

Sample order:
K0323.10

KIPP Spring plungers with slot and pressure pin, standard spring, LONG-LOK secured

Order No.	D	D1	L	L1	H	N	Spring force initial pressure F1 approx. N	Spring force final pressure F2 approx. N	Tightening torque approx. Nm	Loosening torque, after third unscrewing approx. Nm	Approx. weight g
K0323.04	M4	1,8	9	5	1,5	0,6	6	20	0,18	0,12	0,39
K0323.05	M5	2,4	12	6	2	0,8	6	20	0,12	0,08	1
K0323.06	M6	2,7	14	7	2	1	7	20	0,44	0,21	1,7
K0323.08	M8	4	16	8	2	1,2	15	30	1,10	0,38	4
K0323.10	M10	4,5	19	9	2,5	1,6	20	35	1,36	0,62	7
K0323.12	M12	6	22	10	3,5	2	30	55	2,11	1,41	13
K0323.16	M16	8,5	24	14	4,5	2,5	45	100	3,95	3,05	24

KIPP Spring plungers with slot and pressure pin, light spring, LONG-LOK secured

Order No.	D	D1	L	L1	H	N	Spring force initial pressure F1 approx. N	Spring force final pressure F2 approx. N	Tightening torque approx. Nm	Loosening torque, after third unscrewing approx. Nm	Approx. weight g
K0323.104	M4	1,8	9	5	1,5	0,6	3	10	0,18	0,12	0,39
K0323.105	M5	2,4	12	6	2	0,8	3	10	0,12	0,08	1
K0323.106	M6	2,7	14	7	2	1	4	10	0,44	0,21	1,7
K0323.108	M8	4	16	8	2	1,2	7	15	1,10	0,38	4
K0323.110	M10	4,5	19	9	2,5	1,6	9	16	1,36	0,62	7
K0323.112	M12	6	22	10	3,5	2	14	26	2,11	1,41	13
K0323.116	M16	8,5	24	14	4,5	2,5	22	50	3,95	3,05	24

KIPP Spring plungers with slot and pressure pin, strong spring, LONG-LOK secured

Order No.	D	D1	L	L1	H	N	Spring force initial pressure F1 approx. N	Spring force final pressure F2 approx. N	Tightening torque approx. Nm	Loosening torque, after third unscrewing approx. Nm	Approx. weight g
K0323.205	M5	2,4	12	6	2	0,8	9	25	0,12	0,08	1
K0323.206	M6	2,7	14	7	2	1	11	25	0,44	0,21	1,7
K0323.208	M8	4	16	8	2	1,2	22	43	1,1	0,38	4
K0323.210	M10	4,5	19	9	2,5	1,6	20	54	1,36	0,62	7
K0323.212	M12	6	22	10	3,5	2	36	94	2,11	1,41	13
K0323.216	M16	8,5	24	14	4,5	2,5	60	110	3,99	3,05	29

Spring Plunger

with slot and pressure pin, stainless steel, LONG-LOK secured

K0324

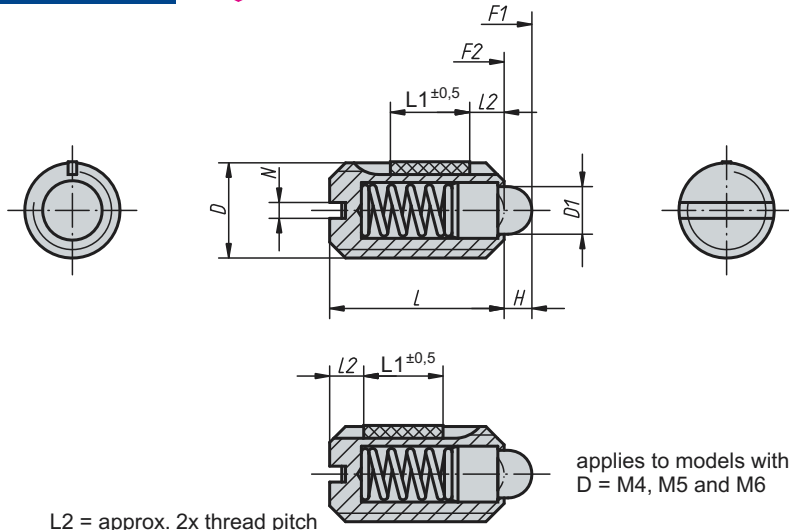

L2 = approx. 2x thread pitch

applies to models with
D = M4, M5 and M6



Material:
Sleeve I.4305.
Pressure pin I.4034.
Spring I.4310.

LONG-LOK thread lock in nylon.

Surface finish:
Natural finish.
Pressure pin hardened.

Sample order:
K0324.10

KIPP Spring plungers with slot and pressure pin, standard spring, LONG-LOK secured

Order No.	D	D1	L	L1	H	N	Spring force initial pressure F1 approx. N	Spring force final pressure F2 approx. N	Tightening torque approx. Nm	Loosening torque, after third unscrewing approx. Nm	Approx. weight g
K0324.04	M4	1,8	9	5	1,5	0,6	6	20	0,18	0,12	0,39
K0324.05	M5	2,4	12	6	2	0,8	6	20	0,12	0,08	1
K0324.06	M6	2,7	14	7	2	1	7	20	0,44	0,21	1,7
K0324.08	M8	4	16	8	2	1,2	15	30	1,10	0,38	4
K0324.10	M10	4,5	19	9	2,5	1,6	20	35	1,36	0,62	7
K0324.12	M12	6	22	10	3,5	2	30	55	2,11	1,41	13
K0324.16	M16	8,5	24	14	4,5	2,5	45	100	3,95	3,05	24

KIPP Spring plungers with slot and pressure pin, light spring, LONG-LOK secured

Order No.	D	D1	L	L1	H	N	Spring force initial pressure F1 approx. N	Spring force final pressure F2 approx. N	Tightening torque approx. Nm	Loosening torque, after third unscrewing approx. Nm	Approx. weight g
K0324.104	M4	1,8	9	5	1,5	0,6	3	10	0,18	0,12	0,39
K0324.105	M5	2,4	12	6	2	0,8	3	10	0,12	0,08	1
K0324.106	M6	2,7	14	7	2	1	4	10	0,44	0,21	1,7
K0324.108	M8	4	16	8	2	1,2	7	15	1,10	0,38	4
K0324.110	M10	4,5	19	9	2,5	1,6	9	16	1,36	0,62	7
K0324.112	M12	6	22	10	3,5	2	14	26	2,11	1,41	13
K0324.116	M16	8,5	24	14	4,5	2,5	22	50	3,95	3,05	24

KIPP Spring plungers with slot and pressure pin, strong spring, LONG-LOK secured

Order No.	D	D1	L	L1	H	N	Spring force initial pressure F1 approx. N	Spring force final pressure F2 approx. N	Tightening torque approx. Nm	Loosening torque, after third unscrewing approx. Nm	Approx. weight g
K0324.205	M5	2,4	12	6	2	0,8	9	25	0,12	0,08	1
K0324.206	M6	2,7	14	7	2	1	11	25	0,44	0,21	1,7
K0324.208	M8	4	16	8	2	1,2	22	43	1,1	0,38	4
K0324.210	M10	4,5	19	9	2,5	1,6	20	54	1,36	0,62	7
K0324.212	M12	6	22	10	3,5	2	36	94	2,11	1,41	13
K0324.216	M16	8,5	24	14	4,5	2,5	60	110	3,99	3,05	29

Spring Plunger

with hexagon socket and ball, steel, LONG-LOK secured

K0325

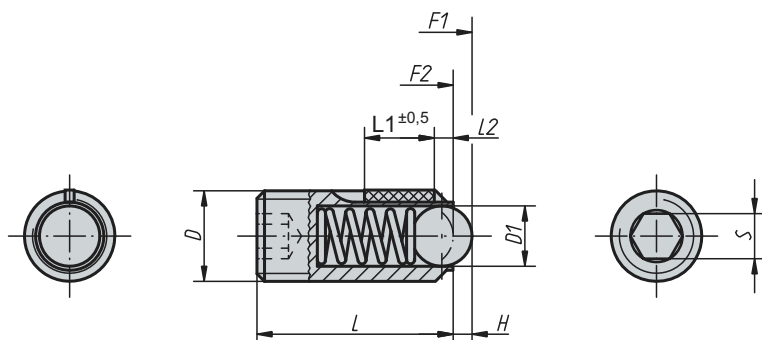

L2 = approx. 2x thread pitch

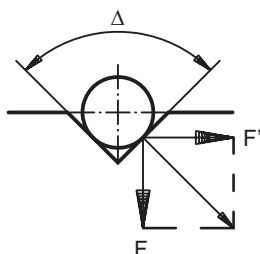

$\Delta = 60^\circ, F' = 1.732 \times F$
 $\Delta = 90^\circ, F' = F$
 $\Delta = 120^\circ, F' = 0.577 \times F$



Material:
 Body in steel quality class 5.8.
 Ball in steel.
 Spring in spring steel class D.

LONG-LOK thread lock in nylon.

Surface finish:
 Black oxide finish.
 Ball hardened.

Sample order:
 K0325.08

KIPP Spring plungers with hexagon socket and ball, standard spring force, LONG-LOK secured

Order No.	D	D1	L	L1	H	N	Spring force initial pressure F1 approx. N	Spring force final pressure F2 approx. N	Tightening torque approx. Nm	Loosening torque, after third unscrewing approx. Nm	Approx. weight g
K0325.03	M3	1,5	9	4	0,4	1,5	1,5	3	0,10	0,07	0,23
K0325.04	M4	2,5	10	5	0,8	2	4	10	0,18	0,12	0,46
K0325.05	M5	3	14	6	0,9	2,5	6	11	0,12	0,08	1,27
K0325.06	M6	3,5	15	7	1	3	9	13	0,44	0,21	2
K0325.08	M8	5	18	8	1,5	4	15	30	1,10	0,38	4
K0325.10	M10	6	23	9	2	5	20	35	1,30	0,60	8
K0325.12	M12	8	26	10	2,5	6	30	55	2,00	1,30	12
K0325.16	M16	10	33	14	3,5	8	65	125	3,90	3,00	31

KIPP Spring plungers with hexagon socket and ball, strong spring force, LONG-LOK secured

Order No.	D	D1	L	L1	H	N	Spring force initial pressure F1 approx. N	Spring force final pressure F2 approx. N	Tightening torque approx. Nm	Loosening torque, after third unscrewing approx. Nm	Approx. weight g
K0325.203	M3	1,5	9	4	0,4	1,5	5	7	0,10	0,07	0,23
K0325.204	M4	2,5	10	5	0,8	2	12	22	0,18	0,12	0,46
K0325.205	M5	3	14	6	0,9	2,5	19	30	0,12	0,08	1,27
K0325.206	M6	3,5	15	7	1	3	28	40	0,44	0,21	2
K0325.208	M8	5	18	8	1,5	4	47	73	1,10	0,38	4
K0325.210	M10	6	23	9	2	5	66	100	1,30	0,60	8
K0325.212	M12	8	26	10	2,5	6	66	120	2,00	1,30	12
K0325.216	M16	10	33	14	3,5	8	90	180	3,90	3,00	31

Spring Plunger

with hexagon socket and ball, stainless steel, LONG-LOK secured

K0326

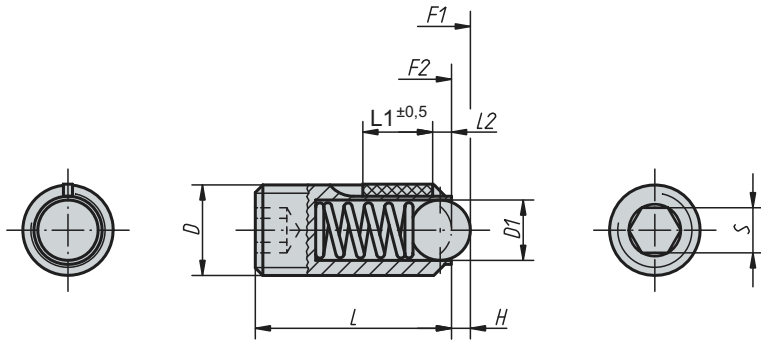

L2 = approx. 2x thread pitch

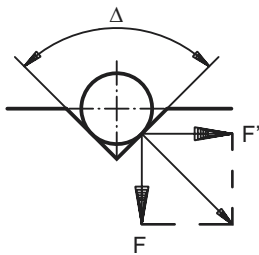

$\Delta = 60^\circ, F' = 1.732 \times F$
 $\Delta = 90^\circ, F' = F$
 $\Delta = 120^\circ, F' = 0.577 \times F$



Material:
 Sleeve I.4305.
 Ball I.4034.
 Spring I.4310.

LONG-LOK thread lock in nylon.

Surface finish:
 Natural finish.
 Ball hardened.

Sample order:
 K0326.08

KIPP Spring plungers with hexagon socket and ball, standard spring force, LONG-LOK secured

Order No.	D	D1	L	L1	H	N	Spring force initial pressure F1 approx. N	Spring force final pressure F2 approx. N	Tightening torque approx. Nm	Loosening torque, after third unscrewing approx. Nm	Approx. weight g
K0326.03	M3	1,5	9	4	0,4	1,5	1,5	3	0,10	0,07	0,23
K0326.04	M4	2,5	10	5	0,8	2	4	10	0,18	0,12	0,46
K0326.05	M5	3	14	6	0,9	2,5	6	11	0,12	0,08	1,27
K0326.06	M6	3,5	15	7	1	3	9	13	0,44	0,21	2
K0326.08	M8	5	18	8	1,5	4	15	30	1,10	0,38	4
K0326.10	M10	6	23	9	2	5	20	35	1,30	0,60	8
K0326.12	M12	8	26	10	2,5	6	30	55	2,00	1,30	12
K0326.16	M16	10	33	14	3,5	8	65	125	3,90	3,00	31

KIPP Spring plungers with hexagon socket and ball, strong spring force, LONG-LOK secured

Order No.	D	D1	L	L1	H	N	Spring force initial pressure F1 approx. N	Spring force final pressure F2 approx. N	Tightening torque approx. Nm	Loosening torque, after third unscrewing approx. Nm	Approx. weight g
K0326.203	M3	1,5	9	4	0,4	1,5	5	7	0,10	0,07	0,23
K0326.204	M4	2,5	10	5	0,8	2	12	22	0,18	0,12	0,46
K0326.205	M5	3	14	6	0,9	2,5	19	30	0,12	0,08	1,27
K0326.206	M6	3,5	15	7	1	3	28	40	0,44	0,21	2
K0326.208	M8	5	18	8	1,5	4	47	73	1,10	0,38	4
K0326.210	M10	6	23	9	2	5	66	100	1,30	0,60	8
K0326.212	M12	8	26	10	2,5	6	66	120	2,00	1,30	12
K0326.216	M16	10	33	14	3,5	8	90	180	3,90	3,00	31

Spring Plunger

with hexagon socket and pressure pin, steel, LONG-LOK secured

K0327

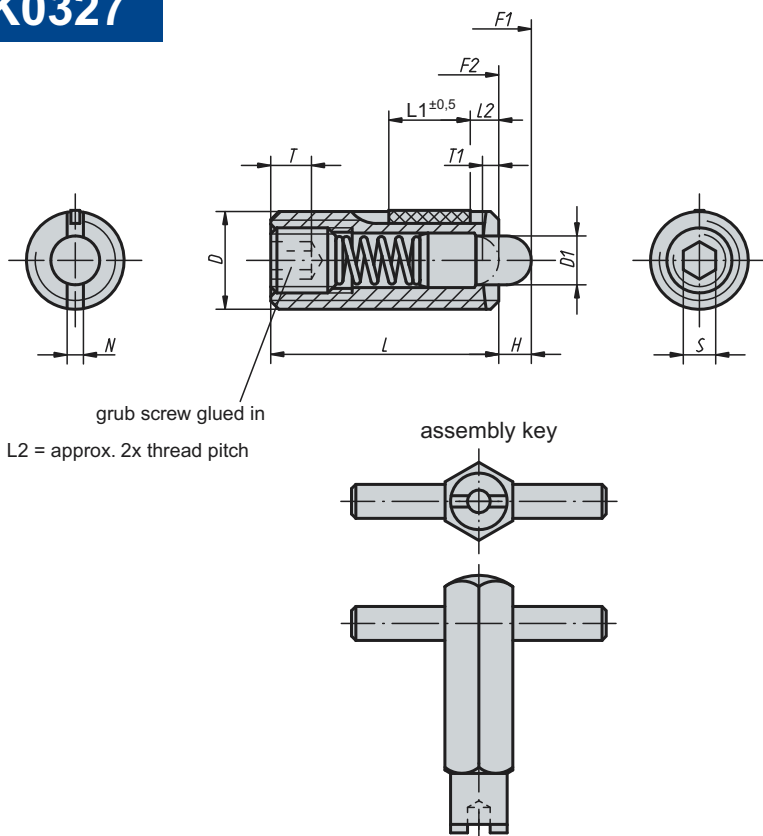

Material:
Body in steel quality class 5.8.
Pressure pin in steel.
Spring in spring steel class D.

LONG-LOK thread lock in nylon.

Surface finish:
Black oxide finish.
Pressure pin hardened.

Sample order:
K0327.12

KIPP Spring plungers with hexagon socket and pressure pin, standard spring force, LONG-LOK secured

Order No.	D	D1	L	L1	H	T	T1	N	S	Spring force initial pressure F1 approx. N	Spring force initial pressure F2 approx. N	Tightening torque approx. Nm	Loosening torque, after third unscrewing approx. Nm	Approx weight g	Order No. assembly key
K0327.05	M5	2,4	18	7	2,3	2	0,8	0,8	1,5	6	20	0,12	0,08	1,3	K0317.905
K0327.06	M6	2,7	20	7	2,5	2,5	1	1	2	7	20	0,45	0,22	2,5	K0317.906
K0327.08	M8	3,5	22	8	3	3	1,4	1,2	2,5	9	35	1,05	0,37	6	K0317.908
K0327.10	M10	4	22	9	3	3,5	1,4	1,6	3	9	35	1,30	0,60	9	K0317.910
K0327.12	M12	6	28	10	4	5	2	2	4	10	55	2,00	1,30	16	K0317.912
K0327.16	M16	7,5	32	14	5	6	2,5	2,5	5	45	100	3,90	3,00	35	K0317.916

KIPP Spring plungers with hexagon socket and pressure pin, light spring force, LONG-LOK secured

Order No.	D	D1	L	L1	H	T	T1	N	S	Spring force initial pressure F1 approx. N	Spring force initial pressure F2 approx. N	Tightening torque approx. Nm	Loosening torque, after third unscrewing approx. Nm	Approx weight g	Order No. assembly key
K0327.105	M5	2,4	18	7	2,3	2	0,8	0,8	1,5	3	10	0,12	0,08	1,3	K0317.905
K0327.106	M6	2,7	20	7	2,5	2,5	1	1	2	3	9	0,45	0,22	2,5	K0317.906
K0327.108	M8	3,5	22	8	3	3	1,4	1,2	2,5	4	16	1,05	0,37	6	K0317.908
K0327.110	M10	4	22	9	3	3,5	1,4	1,6	3	4	16	1,30	0,60	9	K0317.910
K0327.112	M12	6	28	10	4	5	2	2	4	5	27	2,00	1,30	16	K0317.912
K0327.116	M16	7,5	32	14	5	6	2,5	2,5	5	20	45	3,90	3,00	35	K0317.916

KIPP Spring plungers with hexagon socket and pressure pin, strong spring force, LONG-LOK secured

Order No.	D	D1	L	L1	H	T	T1	N	S	Spring force initial pressure F1 approx. N	Spring force initial pressure F2 approx. N	Tightening torque approx. Nm	Loosening torque, after third unscrewing approx. Nm	Approx weight g	Order No. assembly key
K0327.205	M5	2,4	18	7	2,3	2	0,8	0,8	1,5	11	29	0,12	0,08	1,3	K0317.905
K0327.206	M6	2,7	20	7	2,5	2,5	1	1	2	14	37	0,45	0,22	2,5	K0317.906
K0327.208	M8	3,5	22	8	3	3	1,4	1,2	2,5	22	65	1,05	0,37	6	K0317.908
K0327.210	M10	4	22	9	3	3,5	1,4	1,6	3	19	70	1,30	0,60	9	K0317.910
K0327.212	M12	6	28	10	4	5	2	2	4	25	85	2,00	1,30	16	K0317.912
K0327.216	M16	7,5	32	14	5	6	2,5	2,5	5	60	150	3,90	3,00	35	K0317.916

Spring Plunger

with hexagon socket and pressure pin, stainless steel, LONG-LOK secured

K0329

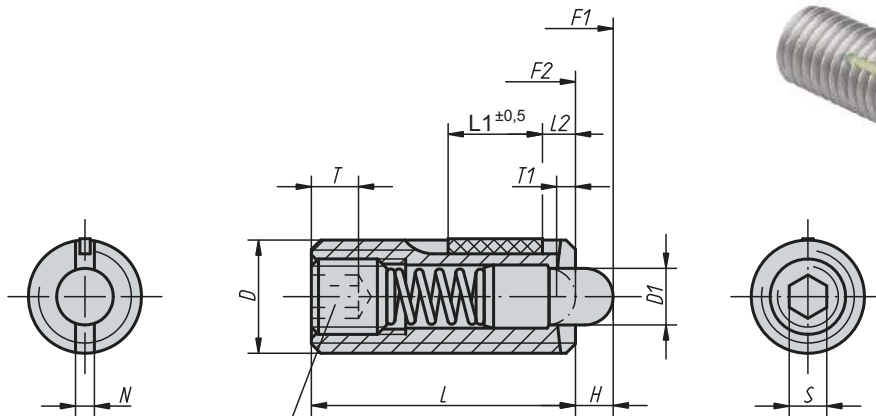

grub screw glued in
L2 = approx. 2x thread pitch



Material:
Sleeve 1.4305.
Pressure pin 1.4034.
Spring 1.4310.

LONG-LOK thread lock in nylon.

Surface finish:
Natural finish.
Pressure pin hardened.

Sample order:
K0329.12

assembly key

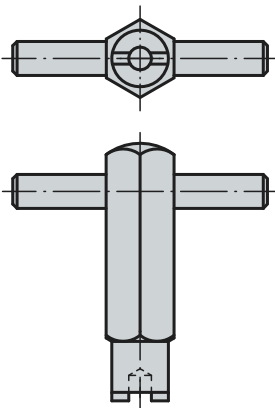

KIPP Spring plungers with hexagon socket and pressure pin, standard spring force, LONG-LOK secured

Order No.	D	D1	L	L1	H	T	T1	N	S	Spring force initial pressure F1 approx. N	Spring force initial pressure F2 approx. N	Tightening torque approx. Nm	Loosening torque, after third unscrewing approx. Nm	Approx weight g	Order No. assembly key
K0329.05	M5	2,4	18	7	2,3	2	0,8	0,8	1,5	5	17	0,12	0,08	1,3	K0317.905
K0329.06	M6	2,7	20	7	2,5	2,5	1	1	2	6	17	0,45	0,22	2,5	K0317.906
K0329.08	M8	3,5	22	8	3	3	1,4	1,2	2,5	7	29	1,05	0,37	6	K0317.908
K0329.10	M10	4	22	9	3	3,5	1,4	1,6	3	8	31	1,30	0,60	9	K0317.910
K0329.12	M12	6	28	10	4	5	2	2	4	10	47	2,00	1,30	16	K0317.912
K0329.16	M16	7,5	32	14	5	6	2,5	2,5	5	45	100	3,90	3,00	35	K0317.916

KIPP Spring plungers with hexagon socket and pressure pin, strong spring force, LONG-LOK secured

Order No.	D	D1	L	L1	H	T	T1	N	S	Spring force initial pressure F1 approx. N	Spring force initial pressure F2 approx. N	Tightening torque approx. Nm	Loosening torque, after third unscrewing approx. Nm	Approx weight g	Order No. assembly key
K0329.205	M5	2,4	18	7	2,3	2	0,8	0,8	1,5	9	26	0,12	0,08	1,3	K0317.905
K0329.206	M6	2,7	20	7	2,5	2,5	1	1	2	11	35	0,45	0,22	2,5	K0317.906
K0329.208	M8	3,5	22	8	3	3	1,4	1,2	2,5	15	48	1,05	0,37	6	K0317.908
K0329.210	M10	4	22	9	3	3,5	1,4	1,6	3	15	58	1,30	0,60	9	K0317.910
K0329.212	M12	6	28	10	4	5	2	2	4	19	74	2,00	1,30	16	K0317.912

Lateral Spring Plunger

K0368

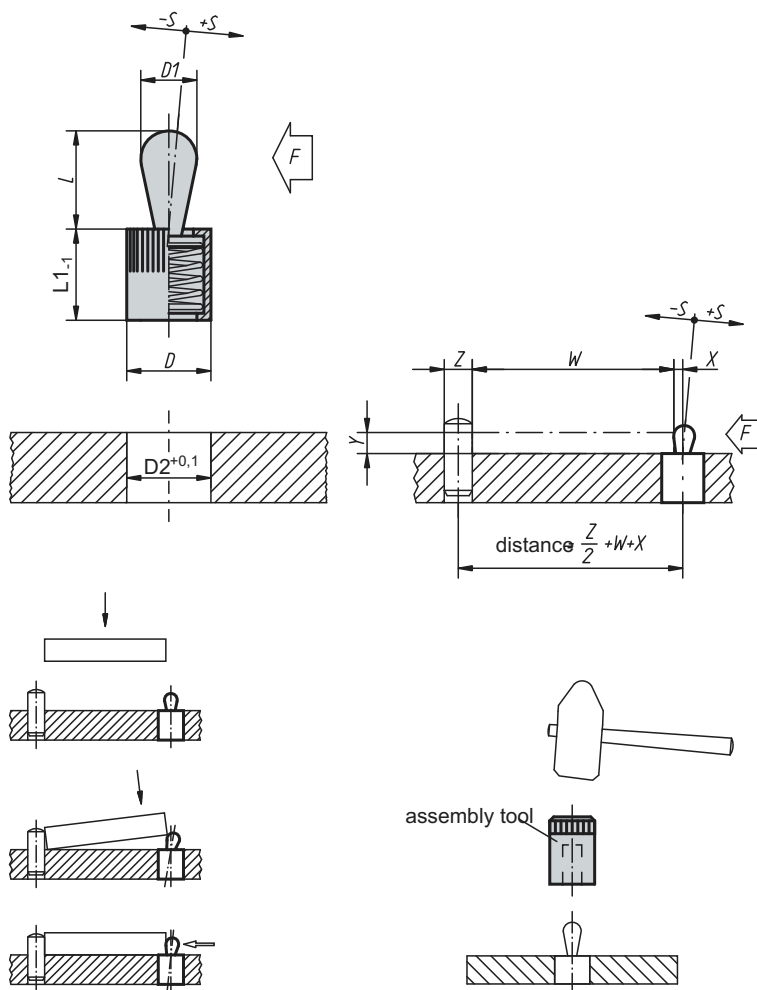

Material:
 Sleeve in aluminium.
 Spring in steel.
 Pressure pin in steel or in POM.

Surface finish:
 Pressure pin (steel) surface hardened and galvanized.
 Sleeve blue galvanized.

Sample order:
 K0368.72064

Note:
 Lateral spring plungers aid in the positioning and clamping, holding and fastening of tools and parts during engraving, labelling, drilling, galling, threading, honing, grinding, welding, soldering, hard-facing, assembling, etc.
 In order to position, see K0369 for suitable eccentric bushes.
 W and Z according to customer specifications.

KIPP Lateral spring plungers without seal, pressure pin and spring in steel

Order No.	D	D1	L	L1	D2	±S	F	X if approx. N Y = 1	X if Y = 2	X if Y = 3	X if Y = 4.5	X if Y = 6	X if Y = 8	Approx. weight g	Order No. assembly tool
K0368.21034	6	3	4	7	6	0,5	10	0,8	1	1	1	1	1	0,6	K0369.03
K0368.21036	6	3	4	7	6	0,5	20	0,8	1	1	1	1	1	0,6	K0369.03
K0368.21038	6	3	4	7	6	0,5	40	0,8	1	1	1	1	1	0,7	K0369.03
K0368.21054	10	5	6,7	11	10	0,8	20	-	1,5	1,7	1,7	1,7	1,7	2,7	K0369.05
K0368.21056	10	5	6,7	11	10	0,8	50	-	1,5	1,7	1,7	1,7	1,7	2,8	K0369.05
K0368.21058	10	5	6,7	11	10	0,8	100	-	1,5	1,7	1,7	1,7	1,7	3,1	K0369.05
K0368.21064	10	6	10,7	11	10	1	40	-	-	-	1,7	1,9	1,9	3,4	K0369.05
K0368.21066	10	6	10,7	11	10	1	75	-	-	-	1,7	1,9	1,9	3,6	K0369.05
K0368.21068	10	6	10,7	11	10	1	150	-	-	-	1,7	1,9	1,9	3,8	K0369.05
K0368.21084	12	8	13,9	13	12	1,3	50	-	-	-	-	2,5	2,7	6,8	K0369.08
K0368.21086	12	8	13,9	13	12	1,3	100	-	-	-	-	2,5	2,7	7,4	K0369.08
K0368.21088	12	8	13,9	13	12	1,3	200	-	-	-	-	2,5	2,7	7,4	K0369.08
K0368.21104	16	10	16,7	17	16	1,6	100	-	-	-	-	-	3,1	15,0	K0369.10
K0368.21106	16	10	16,7	17	16	1,6	200	-	-	-	-	-	3,1	15,0	K0369.10
K0368.21108	16	10	16,7	17	16	1,6	300	-	-	-	-	-	3,1	15,3	K0369.10

K0368

KIPP Lateral spring plungers with seal, pressure pin and spring in steel

Order No.	D	D1	L	L1	D2	±S	F	X if approx. N	X if Y = 1	X if Y = 2	X if Y = 3	X if Y = 4.5	X if Y = 6	X if Y = 8	Approx. weight g	Order No. assembly tool
K0368.22034	6	3	4	7	6	0,5	10	0,8		1	1	1	1	1	0,6	K0369.03
K0368.22036	6	3	4	7	6	0,5	20	0,8		1	1	1	1	1	0,6	K0369.03
K0368.22038	6	3	4	7	6	0,5	40	0,8		1	1	1	1	1	0,7	K0369.03
K0368.22054	10	5	6	12	10	0,8	20	-		1,5	1,7	1,7	1,7	1,7	2,7	K0369.05
K0368.22056	10	5	6	12	10	0,8	50	-		1,5	1,7	1,7	1,7	1,7	2,9	K0369.05
K0368.22058	10	5	6	12	10	0,8	100	-		1,5	1,7	1,7	1,7	1,7	3,1	K0369.05
K0368.22064	10	6	10	12	10	1	40	-		-	-	1,7	1,9	1,9	3,4	K0369.05
K0368.22066	10	6	10	12	10	1	75	-		-	-	1,7	1,9	1,9	3,6	K0369.05
K0368.22068	10	6	10	12	10	1	150	-		-	-	1,7	1,9	1,9	3,8	K0369.05
K0368.22084	12	8	13	14	12	1,3	50	-		-	-	-	2,5	2,7	7,0	K0369.08
K0368.22086	12	8	13	14	12	1,3	100	-		-	-	-	2,5	2,7	8,0	K0369.08
K0368.22088	12	8	13	14	12	1,3	200	-		-	-	-	2,5	2,7	7,4	K0369.08
K0368.22104	16	10	16	18	16	1,6	100	-		-	-	-	-	3,1	15,0	K0369.10
K0368.22106	16	10	16	18	16	1,6	200	-		-	-	-	-	3,1	15,2	K0369.10
K0368.22108	16	10	16	18	16	1,6	300	-		-	-	-	-	3,1	15,6	K0369.10

KIPP Lateral spring plungers without seal, pressure pin in POM, spring in steel

Order No.	D	D1	L	L1	D2	±S	F	X if approx. N	X if Y = 1	X if Y = 2	X if Y = 3	X if Y = 4.5	X if Y = 6	X if Y = 8	Approx. weight g	Order No. assembly tool
K0368.71034	6	3	4	7	6	0,5	10	0,8		1	1	1	1	1	0,4	K0369.03
K0368.71036	6	3	4	7	6	0,5	20	0,8		1	1	1	1	1	0,4	K0369.03
K0368.71054	10	5	6,7	11	10	0,8	20	-		1,5	1,7	1,7	1,7	1,7	1,3	K0369.05
K0368.71056	10	5	6,7	11	10	0,8	50	-		1,5	1,7	1,7	1,7	1,7	1,3	K0369.05
K0368.71064	10	6	10,7	11	10	1	40	-		-	-	1,7	1,9	1,9	1,5	K0369.05
K0368.71066	10	6	10,7	11	10	1	75	-		-	-	1,7	1,9	1,9	1,5	K0369.05
K0368.71084	12	8	13,9	13	12	1,3	50	-		-	-	-	2,5	2,7	2,	K0369.08
K0368.71086	12	8	13,9	13	12	1,3	100	-		-	-	-	2,5	2,7	2,9	K0369.08
K0368.71104	16	10	16,7	17	16	1,6	100	-		-	-	-	-	3,1	6,6	K0369.10
K0368.71106	16	10	16,7	17	16	1,6	200	-		-	-	-	-	3,1	6,6	K0369.10

KIPP Lateral spring plungers with seal, pressure pin in POM, spring in steel

Order No.	D	D1	L	L1	D2	±S	F	X if approx. N	X if Y = 1	X if Y = 2	X if Y = 3	X if Y = 4.5	X if Y = 6	X if Y = 8	Approx. weight g	Order No. assembly tool
K0368.72034	6	3	4	7	6	0,5	10	0,8		1	1	1	1	1	0,4	K0369.03
K0368.72036	6	3	4	7	6	0,5	20	0,8		1	1	1	1	1	0,4	K0369.03
K0368.72054	10	5	6	12	10	0,8	20	-		1,5	1,7	1,7	1,7	1,7	1,3	K0369.05
K0368.72056	10	5	6	12	10	0,8	50	-		1,5	1,7	1,7	1,7	1,7	1,3	K0369.05
K0368.72064	10	6	10	12	10	1	40	-		-	-	1,7	1,9	1,9	1,5	K0369.05
K0368.72066	10	6	10	12	10	1	75	-		-	-	1,7	1,9	1,9	1,5	K0369.05
K0368.72084	12	8	13	14	12	1,3	50	-		-	-	-	2,5	2,7	3,0	K0369.08
K0368.72086	12	8	13	14	12	1,3	100	-		-	-	-	2,5	2,7	3,0	K0369.08
K0368.72104	16	10	16	18	16	1,6	100	-		-	-	-	-	3,1	6,7	K0369.10
K0368.72106	16	10	16	18	16	1,6	200	-		-	-	-	-	3,1	6,7	K0369.10

Other KIPP Products

Clamping & Tension Levers

K0005 & K0006



Cam Levers & Adjustable cam levers with internal thread and external thread, steel or stainless steel

K0645 & K0647



Cam Levers & Adjustable cam levers with internal thread and external thread in stainless steel

K0646 & K0648



Adjustable Cam levers with plastic handle with internal and external thread steel or stainless steel

K0751



Eccentric Quick Lock

K0118



Expansion cam levers

K0116



Clamping levers with external thread

K0117



Clamping levers with external thread, metal parts in stainless steel

K0120 & K0121



Clamping levers with external thread steel & stainless steel

K0122 & K0123



Clamping levers with external thread steel & stainless steel

K0124



Clamp levers with external thread steel & stainless steel

K0737 & K0738



Clamping levers flat with external thread steel parts stainless steel

K0269 & K0270



Clamping levers with external thread and plastic handle, steel parts in stainless steel

K0125 & K0126



Clamp levers 2K „COCKATOO“ two-component with external thread steel parts in stainless steel

K0252



Clamping lever TOUCAN external thread

K0175



Non-adjustable clamping levers

Other KIPP Products Handles & Knobs

K0137



Knurled Nuts
in steel and stainless steel,
DIN 6303

K0139



Quick-acting knurled nuts

K0140



High knurled thumb screws
in steel and stainless steel, DIN 464

K0145, K0146 & K0147



Palm grips
in Aluminium,
stainless steel, & Grey cast iron

K0149, K0150 & K0151



Star Grips
in Aluminium,
stainless steel, & Grey cast iron

K0138



Plastic knurled nuts

K0144



Thin knurled nuts
in steel and stainless steel, DIN 467

K0142



Knurled knobs

K0613



Palm grips soft

K0152



Star Grips
similar to DIN 6336

K0141



Plastic knurled thumb screws

K0143



High knurled nuts
in steel and stainless steel, DIN 466

K0247



Knurled knobs

K0138



Plastic knurled nuts

K0153



Star grips
with projecting steel bush

Other KIPP Products Handles & Knobs

K0154



Star grips
similar to DIN 6336,
steel parts in stainless steel

K0155



Star grips
similar to DIN 6336

K0156



Quick-acting star grips

K0276



Ribbed grips

K0276 & K0185



Five lobe grips

K0255



Clamp grips

K0183



Triangular star grips with high collar

K0260



Knurled knobs

K0251



Mushroom knobs
with external thread

K0274



Wing grips

K0650



Ball knobs
stainless steel or aluminium
DIN 319

K0159



Ball knobs
with smooth surface to
DIN 319 extended

K0253



Spherical knobs

K0248



Graduated knobs

K0249



Adjusting knobs

Other KIPP Products Device Handles

K0186



Pull handles round, tapped

K0187



Pull handles offset, tapped

K0191



Pull handles bridge, thru hole

K0194



Pull handles bridge, thru hole

K0196



Pull handles arch, tapped

K0197



Pull handles angled, tapped

K0198



Pull handles stainless steel bridge, thru or tapped

K0201



Pull handles round tapped

K0204



Pull handles oval tapped

K0207



Pull handles angled machine grip tapped

K0209



Pull handles general purpose machine grips thru hole

K0210



Pull handles lightweight thru hole

K0231



Pull handle Bighand

K0232



Pull handles ledge tapped

K0239



Pull handles recessed fold-out

Other KIPP Products

Handwheels

K0725



Handwheels
2-spoke plastic,
with revolving grip

K0161



Handwheels disc
aluminium

K0257



Handwheels
with revolving cylinder grip

K0726



Ball grip rotatable

K0659



Crank handles
with cylindrical revolving grip,
with square socket

K0671



Handwheels
DIN 950 grey cast iron

K0162



Handwheels
2-spoke aluminium,
with flat wheel rim

K0262



Positioning wheels

K0684



Offset crank handles
similar to DIN 468

K0740



Cylindrical revolving grips
with hexagon socket

K0160



Handwheels
DIN 950, aluminium

K0197



Handwheels disc
with revolving grip

K0275



Delta wheels

K0727



Aluminium crank handles

K0408



Digital position indicators

Other KIPP Products Spring Plungers & Locating Pins

K0333



smooth version,
Spring plungers
extended, stainless steel

K0339



Indexing plungers

K0635



Indexing plungers
without collar

K0348



Cam-action indexing plungers

K0363



Ball locking bolts self-locking

K0582



Spring plungers
with arrest ring

K0340



Indexing plungers

K0359



Precision indexing plungers
with tapered pin

K0639



Cam-action indexing plungers

K0364



Ball locking bolts
in stainless steel self-locking

K0338



Indexing plungers

K0342



Indexing plungers

K0245



Indexing and clamp grips

K0349



Locking bar

K0642



Ball locking bolts with L-grip self-locking

Other KIPP Products

Support, locating and stop elements

K0282



Self-aligning pads

K0385



Round grippers and inserts

K0287



Self-aligning pads adjustable

K0288



Adjustable toggle locators with o-ring

K0290



Self-aligning pads adjustable with o-ring and hexagon socket

K0380



Ball-end thrust screws with head

K0383



Ball-end thrust screws without head with flattened ball

K0386



Hexagonal grippers

K0387

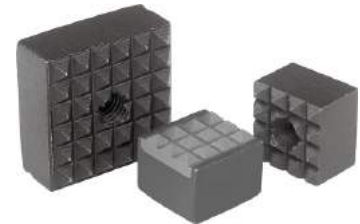

Square grippers

K0350



Locating pins with ball-end Form A

K0351



Locating pins with flattened ball-end

K0352



Cylindrical positioning pins ground

K0356



Locating bolts spread type

K0294



Rest pads

K0692



Height adjustment bolts

Other KIPP Products

Hinges

K0434



Hinges in plastic, detachable, left

K0435



Hinges in plastic

K0436



Hinges in plastic with clamping function

K0437



Hinge plastic, with oblong holes

K0438



Hinges plastic, with guide tabs, detachable

K0439



Hinges in plastic with a catching function

K0441



Hinges, die cast zinc with oblong holes

K0442



Hinges in die cast zinc with clamping function

K0579



Hinges in aluminium, detachable, left

Other Line of Products

Steel Pallets

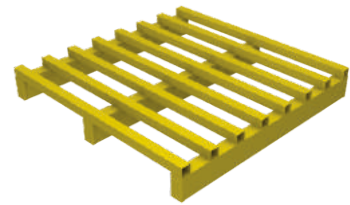
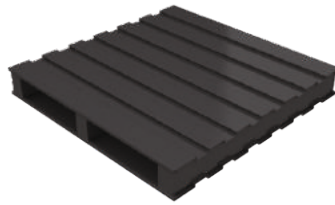
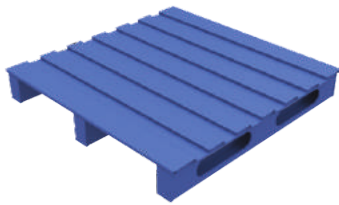

Cage Bins

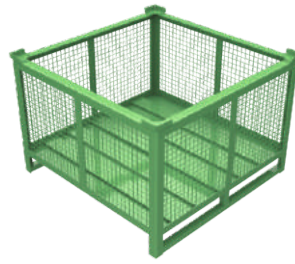

Drum Pallets

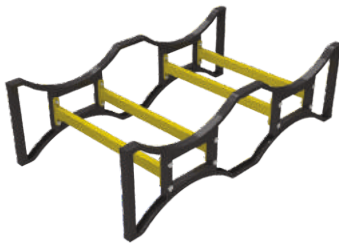

Corrugated Steel Boxes



Snout End Bins

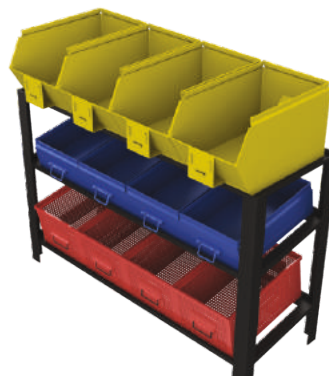

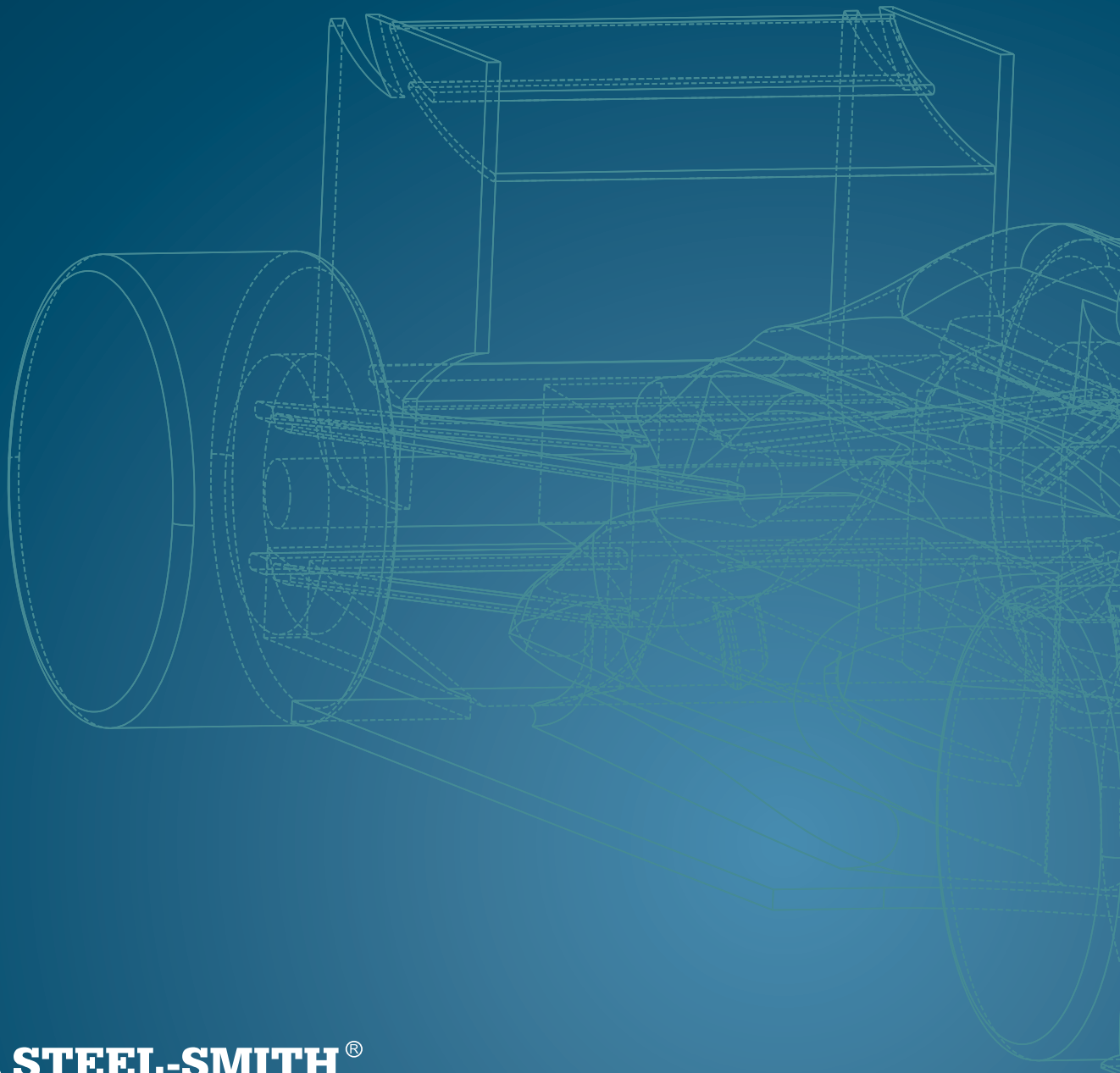

STEEL-SMITH®

Clamps on the go... that never let go!

Plot No. 12, Sector - 2,
Vasai Taluka Ind Estate, Gaurapada,
Vasai (E), Thane - 401 208, India.

Tel.: 0250 - 645 7800 / 645 7836
E-mail: catalogue@steelsmith.com
Website: www.steelsmith.com